

# DENON

AV SURROUND PRE-AMPLIFIER

# AVP-A1HDCI

---

Owner's Manual

**GUI** *Graphical User Interface*

Use this manual in combination with the operating guide displayed on the GUI screen.

GUI Menu Operation (☞ page 24)

GUI Menu Map (☞ page 25)

Language (☞ page 44)

Remote Control Unit Operations (☞ page 77)

## SAFETY PRECAUTIONS

**CAUTION**  
**RISK OF ELECTRIC SHOCK**  
**DO NOT OPEN**

**CAUTION:**  
**TO REDUCE THE RISK OF ELECTRIC SHOCK, DO NOT REMOVE COVER (OR BACK). NO USER-SERVICEABLE PARTS INSIDE. REFER SERVICING TO QUALIFIED SERVICE PERSONNEL.**

The lightning flash with arrowhead symbol, within an equilateral triangle, is intended to alert the user to the presence of uninsulated "dangerous voltage" within the product's enclosure that may be of sufficient magnitude to constitute a risk of electric shock to persons.

The exclamation point within an equilateral triangle is intended to alert the user to the presence of important operating and maintenance (servicing) instructions in the literature accompanying the appliance.

**WARNING:**  
**TO REDUCE THE RISK OF FIRE OR ELECTRIC SHOCK, DO NOT EXPOSE THIS APPLIANCE TO RAIN OR MOISTURE.**

# SAFETY INSTRUCTIONS

1. Read Instructions – All the safety and operating instructions should be read before the product is operated.
2. Retain Instructions – The safety and operating instructions should be retained for future reference.
3. Heed Warnings – All warnings on the product and in the operating instructions should be adhered to.
4. Follow Instructions – All operating and use instructions should be followed.
5. Cleaning – Unplug this product from the wall outlet before cleaning. Do not use liquid cleaners or aerosol cleaners.
6. Attachments – Do not use attachments not recommended by the product manufacturer as they may cause hazards.
7. Water and Moisture – Do not use this product near water – for example, near a bath tub, wash bowl, kitchen sink, or laundry tub; in a wet basement; or near a swimming pool; and the like.
8. Accessories – Do not place this product on an unstable cart, stand, tripod, bracket, or table. The product may fall, causing serious injury to a child or adult, and serious damage to the product. Use only with a cart, stand, tripod, bracket, or table recommended by the manufacturer, or sold with the product. Any mounting of the product should follow the manufacturer's instructions, and should use a mounting accessory recommended by the manufacturer.
9. A product and cart combination should be moved with care. Quick stops, excessive force, and uneven surfaces may cause the product and cart combination to overturn.
10. Ventilation – Slots and openings in the cabinet are provided for ventilation and to ensure reliable operation of the product and to protect it from overheating, and these openings must not be blocked or covered. The openings should never be blocked by placing the product on a bed, sofa, rug, or other similar surface. This product should not be placed in a built-in installation such as a bookcase or rack unless proper ventilation is provided or the manufacturer's instructions have been adhered to.
11. Power Sources – This product should be operated only from the type of power source indicated on the marking label. If you are not sure of the type of power supply to your home, consult your product dealer or local power company. For products intended to operate from battery power, or other sources, refer to the operating instructions.
12. Grounding or Polarization – This product may be equipped with a polarized alternating-current line plug (a plug having one blade wider than the other). This plug will fit into the power outlet only one way. This is a safety feature. If you are unable to insert the plug fully into the outlet, try reversing the plug. If the plug should still fail to fit, contact your electrician to replace your obsolete outlet. Do not defeat the safety purpose of the polarized plug.
13. Power-Cord Protection – Power-supply cords should be routed so that they are not likely to be walked on or pinched by items placed upon or against them, paying particular attention to cords at plugs, convenience receptacles, and the point where they exit from the product.
15. Outdoor Antenna Grounding – If an outside antenna or cable system is connected to the product, be sure the antenna or cable system is grounded so as to provide some protection against voltage surges and built-up static charges. Article 810 of the National Electrical Code, ANSI/NFPA 70, provides information with regard to proper grounding of the mast and supporting structure, grounding of the lead-in wire to an antenna discharge unit, size of grounding conductors, location of antenna-discharge unit, connection to grounding electrodes, and requirements for the grounding electrode. See Figure A.
16. Lightning – For added protection for this product during a lightning storm, or when it is left unattended and unused for long periods of time, unplug it from the wall outlet and disconnect the antenna or cable system. This will prevent damage to the product due to lightning and power-line surges.
17. Power Lines – An outside antenna system should not be located in the vicinity of overhead power lines or other electric light or power circuits, or where it can fall into such power lines or circuits. When installing an outside antenna system, extreme care should be taken to keep from touching such power lines or circuits as contact with them might be fatal.
18. Overloading – Do not overload wall outlets, extension cords, or integral convenience receptacles as this can result in a risk of fire or electric shock.
19. Object and Liquid Entry – Never push objects of any kind into this product through openings as they may touch dangerous voltage points or short-out parts that could result in a fire or electric shock. Never spill liquid of any kind on the product.
20. Servicing – Do not attempt to service this product yourself as opening or removing covers may expose you to dangerous voltage or other hazards. Refer all servicing to qualified service personnel.
21. Damage Requiring Service – Unplug this product from the wall outlet and refer servicing to qualified service personnel under the following conditions:
  - a) When the power-supply cord or plug is damaged,
  - b) If liquid has been spilled, or objects have fallen into the product,
  - c) If the product has been exposed to rain or water,
  - d) If the product does not operate normally by following the operating instructions. Adjust only those controls that are covered by the operating instructions as an improper adjustment of other controls may result in damage and will often require extensive work by a qualified technician to restore the product to its normal operation,
  - e) If the product has been dropped or damaged in any way, and
  - f) When the product exhibits a distinct change in performance – this indicates a need for service.
22. Replacement Parts – When replacement parts are required, be sure the service technician has used replacement parts specified by the manufacturer or have the same characteristics as the original part. Unauthorized substitutions may result in fire, electric shock, or other hazards.
23. Safety Check – Upon completion of any service or repairs to this product, ask the service technician to perform safety checks to determine that the product is in proper operating condition.
24. Wall or Ceiling Mounting – The product should be mounted to a wall or ceiling only as recommended by the manufacturer.
25. Heat – The product should be situated away from heat sources such as radiators, heat registers, stoves, or other products (including amplifiers) that produce heat.

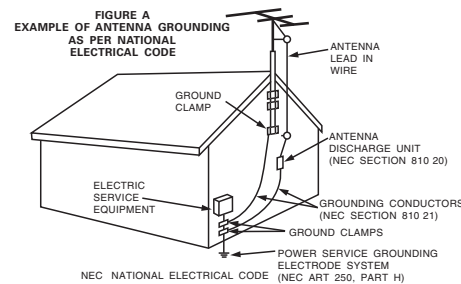

## FCC Information (For US customers)

### 1. COMPLIANCE INFORMATION

**Product Name: AV Surround Pre-Amplifier**

**Model Number: AVP-A1HDCI**

**This product contains FCC ID: BV2- MPGBR052.**

This product complies with Part 15 of the FCC Rules. Operation is subject to the following two conditions: (1) this product may not cause harmful interference, and (2) this product must accept any interference received, including interference that may cause undesired operation.

Denon Electronics (USA), LLC  
100 Corporate Drive, Mahwah, NJ 07430-2041  
Tel. 201-762-6500 (Main)

### 2. IMPORTANT NOTICE: DO NOT MODIFY THIS PRODUCT

This product, when installed as indicated in the instructions contained in this manual, meets FCC requirements. Modification not expressly approved by DENON may void your authority, granted by the FCC, to use the product.

### 3. CAUTION

- To comply with FCC RF exposure compliance requirement, separation distance of at least 20 cm must be maintained between the antenna of this product and all persons.
- This product and its antenna must not be co-located or operating in conjunction with any other antenna or transmitter.

### 4. NOTE

This product has been tested and found to comply with the limits for a Class B digital device, pursuant to Part 15 of the FCC Rules. These limits are designed to provide reasonable protection against harmful interference in a residential installation.

This product generates, uses and can radiate radio frequency energy and, if not installed and used in accordance with the instructions, may cause harmful interference to radio communications. However, there is no guarantee that interference will not occur in a particular installation. If this product does cause harmful interference to radio or television reception, which can be determined by turning the product OFF and ON, the user is encouraged to try to correct the interference by one or more of the following measures:

- Reorient or relocate the receiving antenna.
- Increase the separation between the equipment and receiver.
- Connect the product into an outlet on a circuit different from that to which the receiver is connected.
- Consult the local retailer authorized to distribute this type of product or an experienced radio/TV technician for help.

## IC Information (For Canadian customers)

### 1. PRODUCT

**This product contains IC 6963A-MPGBR052.**

This product complies with RSS-210 of Industry Canada. Operation is subject to the following two conditions: (1) this product may not cause harmful interference, and (2) this product must accept any interference received, including interference that may cause undesired operation.

This Class B digital apparatus complies with Canadian ICES-003.

#### APPAREIL

**Cet appareil contient IC 6963A- MPGBR052.**

Cet appareil est conforme à la norme CNR-210 du Canada. L'utilisation de ce dispositif est autorisée seulement aux deux conditions suivantes : (1) il ne doit pas produire de brouillage, et (2) l'utilisateur du dispositif doit être prêt à accepter tout brouillage radioélectrique reçu, même si ce brouillage est susceptible de compromettre le fonctionnement du dispositif.

Cet appareil numérique de la classe B est conforme à la norme NMB-003 du Canada.

### 2. CAUTION

To reduce potential radio interference to other users, the antenna type and its gain should be so chosen that the equivalent isotropically radiated power (e.i.r.p.) is not more than that permitted for successful communication.

#### ATTENTION

Afin de réduire le risque d'interférence aux autres utilisateurs, il faut choisir le type d'antenne et son gain de façon à ce que la puissance isotrope rayonnée équivalente (p.i.r.e.) ne soit pas supérieure au niveau requis pour l'obtention d'une communication satisfaisante.

## NOTE ON USE / OBSERVATIONS RELATIVES A L'UTILISATION

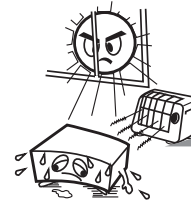

- Avoid high temperatures. Allow for sufficient heat dispersion when installed in a rack.
- Éviter des températures élevées. Tenir compte d'une dispersion de chaleur suffisante lors de l'installation sur une étagère.



- Keep the unit free from moisture, water, and dust.
- Protéger l'appareil contre l'humidité, l'eau et la poussière.



- Do not let foreign objects into the unit.
- Ne pas laisser des objets étrangers dans l'appareil.

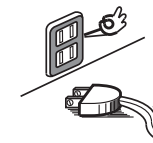

- Unplug the power cord when not using the unit for long periods of time.
- Débrancher le cordon d'alimentation lorsque l'appareil n'est pas utilisé pendant de longues périodes.



- Do not let insecticides, benzene, and thinner come in contact with the unit.
- Ne pas mettre en contact des insecticides, du benzène et un diluant avec l'appareil.

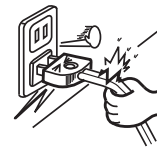

- Handle the power cord carefully. Hold the plug when unplugging the cord.
- Manipuler le cordon d'alimentation avec précaution. Tenir la prise lors du débranchement du cordon.



\* (For apparatuses with ventilation holes)

- Do not obstruct the ventilation holes.
- Ne pas obstruer les trous d'aération.

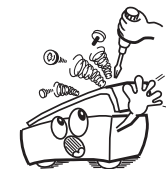

- Never disassemble or modify the unit in any way.
- Ne jamais démonter ou modifier l'appareil d'une manière ou d'une autre.

# Contents

## Getting Started

|  |      |
|--|------|
| Accessories                                | 3    |
| Cautions on Handling                       | 3    |
| Cautions on Installation                   | 3    |
| About the Remote Control Unit              | 3    |
| Inserting the Batteries                    | 3, 4 |
| Operating Range of the Remote Control Unit | 4    |
| Part Names and Functions                   | 4    |
| Front Panel                                | 4, 5 |
| Display                                    | 5    |
| Rear Panel                                 | 6    |
| Remote Control Unit                        | 7    |

## Connections

|   |         |
|---|---------|
| Preparations                                    | 8       |
| Cables Used for Connections                     | 8       |
| Video Conversion Function                       | 9       |
| Speaker Layout                                  | 10      |
| Connecting to the Power Amp                     | 10      |
| POA-A1HDCI Connection and Operation             | 10 ~ 12 |
| Connecting Equipment with HDMI connectors       | 12, 13  |
| Connecting the Monitor                          | 13      |
| Connecting the Playback Components              | 13      |
| DVD Player                                      | 13      |
| Record Player                                   | 14      |
| CD Player                                       | 14      |
| iPod®   | 14      |
| TV/CABLE Tuner                                  | 15      |
| Satellite Receiver                              | 15      |
| Connecting the Recording Components             | 16      |
| Digital Video Recorder                          | 16      |
| Video Cassette Recorder                         | 17      |
| CD Recorder / MD Recorder / Tape Deck           | 17      |
| Connections to Other Devices                    | 18      |
| Components Equipped with a DENON LINK connector | 18      |
| Video Camera / Game Console                     | 18      |
| Component with Multi-channel Output connectors  | 18      |
| USB Port  | 19      |
| XM Connector                                    | 19      |
| Antenna terminals                               | 20      |
| Network Audio                                   | 21      |
| Multi Zone                                      | 22      |
| External Controller                             | 23      |
| Connecting the Power Cord                       | 23      |
| Once Connections are Completed                  | 23      |

## GUI Menu Operations

|   |    |
|---|----|
| Example of the Display of the GUI Mark at a Title | 24 |
| Example of Display of Default Values              | 24 |
| Examples of GUI Screen Displays                   | 24 |
| Example: Browse Menu (Top Menu)                   | 24 |
| Example: Menu with Illustrations (Auto Setup)     | 24 |
| Cursor Position Display                           | 24 |
| Operations  | 24 |
| GUI Menu Map                                      | 25 |

## Auto Setup

|                   |        |
|-------------------|--------|
| Preparations      | 26     |
| Auto Setup        | 26     |
| 1 Auto Setup      | 26, 27 |
| Error Messages    | 28     |
| 2 Option          | 28     |
| 3 Parameter Check | 28     |

## Manual Setup

|                         |         |
|-------------------------|---------|
| Speaker Setup           | 29      |
| 1 Speaker Configuration | 29      |
| 2 Subwoofer Setup       | 29      |
| 3 Distance              | 30      |
| 4 Channel Level         | 30      |
| 5 Crossover Frequency   | 30, 31  |
| 6 THX Audio Setup       | 31      |
| 7 Surround Speaker      | 31      |
| HDMI Setup              | 32      |
| 1 Color Space           | 32      |
| 2 RGB Range             | 32      |
| 3 Auto Lip Sync         | 32      |
| 4 Audio                 | 32      |
| 5 Monitor Out           | 32      |
| 6 HDMI Control          | 32      |
| Audio Setup             | 33      |
| 1 EXT. IN Setup         | 33      |
| 2 2ch Direct/Stereo     | 33      |
| 3 Downmix Option        | 34      |
| 4 Auto Surround Mode    | 34      |
| 5 Manual EQ             | 34      |
| Network Setup           | 35      |
| 1 Network Setup         | 35 ~ 38 |
| 2 Other                 | 38      |
| 3 Network Information   | 38      |
| Zone Setup              | 39      |
| 1 ZONE2                 | 39      |
| 2 ZONE3                 | 39      |
| 3 OSD                   | 39      |

|                     |        |
|---------------------|--------|
| Option Setup        | 40     |
| 1 Pre-out Assign    | 40     |
| 2 XLR Out Polarity  | 41     |
| 3 POA Setting       | 41     |
| 4 Volume Control    | 41     |
| 5 Source Delete     | 41     |
| 6 GUI               | 41, 42 |
| 7 Quick Select Name | 42     |
| 8 Trigger Out 1     | 42     |
| 9 Trigger Out 2     | 42     |
| 10 Trigger Out 3    | 42     |
| 11 Trigger Out 4    | 42     |
| 12 Transducer Setup | 42     |
| 13 Digital Out      | 43     |
| 14 Remote ID        | 43     |
| 15 2Way Remote      | 43     |
| 16 Dimmer           | 43     |
| 17 Setup Lock       | 43     |
| 18 Maintenance Mode | 43     |
| 19 Firmware Update  | 43     |
| 20 Add New Feature  | 44     |
| Language            | 44     |

## Source Select

|   |        |
|---|--------|
| Input Source Selection                    | 45     |
| Settings Related to Playing Input Sources | 45, 46 |
| 1 Play                                    | 46     |
| 2 Auto Preset                             | 46     |
| 3 Preset Skip                             | 46     |
| 4 Preset Name                             | 46     |
| 5 Video                                   | 46, 47 |
| 6 Input Mode                              | 47     |
| 7 Rename                                  | 47     |
| 8 Source Level                            | 47     |
| 9 Input Att.                              | 48     |
| 10 Playback Mode (iPod)                   | 48     |
| 11 Assign                                 | 48, 49 |
| 12 Playback Mode                          | 49     |
| 13 Still Picture                          | 49     |
| 14 Antenna Aiming                         | 49     |



|  |    |
|--|----|
| <b>Surround Mode</b>   |    |
| <b>HOME THX CINEMA</b> .....                                   | 50 |
| Surround Playback of 2-channel Sources .....                   | 50 |
| Playing Multi-channel Sources (Dolby Digital, DTS, etc.) ..... | 50 |
| <b>Standard Playback</b> .....                                 | 50 |
| Surround Playback of 2-channel Sources .....                   | 50 |
| Playing Multi-channel Sources (Dolby Digital, DTS, etc.) ..... | 51 |
| Dolby Headphone .....  | 51 |
| <b>DSP Simulation Playback</b> .....                           | 51 |
| <b>Stereo Playback</b> .....                                   | 51 |
| <b>Direct Playback</b> .....                                   | 52 |
| Playback in the PURE DIRECT Mode .....                         | 52 |

|                                    |         |
|------------------------------------|---------|
| <b>Parameter</b>                   |         |
| <b>Audio</b> .....                 | 52      |
| <b>1</b> Surround Parameters ..... | 52 ~ 54 |
| <b>2</b> Tone .....                | 54, 55  |
| <b>3</b> Room EQ .....             | 55      |
| <b>4</b> Dynamic EQ .....          | 55      |
| <b>5</b> RESTORER .....            | 55      |
| <b>6</b> Night Mode .....          | 55      |
| <b>7</b> Audio Delay .....         | 56      |
| <b>Picture Adjust</b> .....        | 56      |
| <b>1</b> Contrast .....            | 56      |
| <b>2</b> Brightness .....          | 56      |
| <b>3</b> Chroma Level .....        | 56      |
| <b>4</b> Hue .....                 | 56      |
| <b>5</b> DNR .....                 | 56      |
| <b>6</b> Enhancer .....            | 56      |
| <b>7</b> Sharpness .....           | 56      |

|                                   |    |
|-----------------------------------|----|
| <b>Information</b>                |    |
| <b>Status</b> .....               | 56 |
| <b>1</b> MAIN ZONE .....          | 56 |
| <b>2</b> ZONE2/3/4 .....          | 56 |
| <b>Audio Input Signal</b> .....   | 57 |
| <b>HDMI Information</b> .....     | 57 |
| <b>1</b> Signal Information ..... | 57 |
| <b>2</b> Monitor1 .....           | 57 |
| <b>3</b> Monitor2 .....           | 57 |
| <b>Auto Surround Mode</b> .....   | 57 |
| <b>Quick Select</b> .....         | 57 |
| <b>Preset Station</b> .....       | 57 |

|  |        |
|--|--------|
| <b>Playback</b>  |        |
| <b>Preparations</b> .....  | 58     |
| Turning the Power On .....   | 58     |
| Operations During Playback .....                                   | 58     |
| <b>Playing Video and Audio Equipment</b> .....                     | 58     |
| Basic Operation .....  | 58     |
| <b>Listening to FM/AM Broadcasts</b> .....                         | 59     |
| Basic Operation .....  | 59     |
| Presetting Radio Stations (Preset Memory) .....                    | 59     |
| Listening to Preset Stations .....                                 | 59, 60 |
| RDS (Radio Data System) .....                                      | 60     |
| RDS Search .....   | 60     |
| PTY Search .....   | 60     |
| TP Search .....  | 61     |
| RT (Radio Text) .....  | 61     |
| <b>Listening to XM Satellite Radio Programs</b> .....              | 61     |
| Basic Operation .....  | 62     |
| Checking the XM Signal Strength and Radio ID .....                 | 62     |
| Searching Categories .....   | 62     |
| Accessing XM Radio Channels Directly .....                         | 62     |
| <b>Listening to HD Radio™ Stations</b> .....                       | 63     |
| Basic Operation .....  | 63     |
| Selecting Audio Programs .....                                     | 64     |
| Check the HD Radio Reception Information .....                     | 64     |
| <b>iPod® Playback</b> .....  | 64     |
| Basic Operation .....  | 64     |
| Listening to Music .....   | 65     |
| Viewing Still Pictures or Videos on the iPod .....                 | 65     |
| <b>Playing Network Audio, USB Memory Devices or Rhapsody</b> ..... | 66     |
| Basic Operation .....  | 67     |
| Listening to Internet Radio .....                                  | 68     |
| Playing Files Stored on a Computer .....                           | 69     |
| Playing Files Stored on USB Memory Devices .....                   | 69, 70 |
| Listening to Rhapsody .....  | 70     |
| Operating the AVP-A1HDCI .....                                     |        |
| Using a Browser (Web control) .....                                | 71, 72 |

|  |    |
|--|----|
| <b>Other Operations and Functions</b>                |    |
| <b>Other Operations</b> .....                        | 72 |
| Playing Super Audio CD .....                         | 72 |
| Recording on an External Device (REC OUT mode) ..... | 73 |
| <b>Convenient Functions</b> .....                    | 74 |
| HDMI Control Function .....                          | 74 |
| Channel Level .....                                  | 75 |
| Fader Function .....                                 | 75 |
| Quick Select Function .....                          | 75 |
| Personal Memory Plus Function .....                  | 75 |
| Last Function Memory .....                           | 76 |
| Backup Memory .....                                  | 76 |
| Resetting the Microprocessor .....                   | 76 |

|  |         |
|--|---------|
| <b>Remote Control Unit Operations</b>  |         |
| <b>Main Remote Control Unit</b> .....  | 77      |
| Operating DENON Audio Components .....   | 77      |
| Presetting .....   | 77      |
| Operating Preset Components .....  | 77 ~ 79 |
| Setting the Remote ID .....  | 80      |
| Learning Function .....  | 80      |
| System Call Function .....   | 81      |
| Punch Through Function .....   | 81      |
| Setting the Time the Backlight Stays Lit .....   | 82      |
| Adjusting the Backlight's Brightness .....   | 82      |
| Resetting the Main Remote Control Unit .....   | 82      |
| <b>Sub Remote Control Unit Operations</b> .....  | 83, 84  |
| Switching Zones .....  | 85      |
| Setting the Zone for Which the Sub Remote Control Unit is Used (ZONE SELECT LOCK Mode) ..... | 85      |
| Setting the Remote ID .....  | 85      |
| Resetting the Settings .....   | 85      |

|  |    |
|--|----|
| <b>Multi-Zone Connections and Operations</b> |    |
| <b>Multi-Zone Connections</b> .....          | 86 |
| <b>Multi-Zone Operations</b> .....           | 87 |
| Turning the Power On and Off .....           | 87 |
| Selecting the Input Source .....             | 87 |
| Adjusting the Volume .....                   | 87 |
| Turning off the Sound Temporarily .....      | 87 |

|                                |          |
|--------------------------------|----------|
| <b>Other Information</b> ..... | 88 ~ 102 |
|--------------------------------|----------|

|                              |           |
|------------------------------|-----------|
| <b>Troubleshooting</b> ..... | 103 ~ 107 |
|------------------------------|-----------|

|                             |     |
|-----------------------------|-----|
| <b>Specifications</b> ..... | 108 |
|-----------------------------|-----|

|                                   |                    |
|-----------------------------------|--------------------|
| <b>List of preset codes</b> ..... | End of this manual |
|-----------------------------------|--------------------|

# Getting Started

Thank you for purchasing this DENON product. To ensure proper operation, please read this owner's manual carefully before using the product.

After reading them, be sure to keep them for future reference.

## Accessories

Check that the following parts are supplied with the product.

|  |   |
|--|---|
| ① Owner's manual .....                                   | 1 |
| ② Warranty (for North America model only).....           | 1 |
| ③ Service station list .....                             | 1 |
| ④ Power cord (Cord length: Approx. 5 ft /1.5 m) .....    | 1 |
| ⑤ Main remote control (RC-1067) .....                    | 1 |
| ⑥ LR6/AA batteries (for RC-1067) .....                   | 2 |
| ⑦ Sub remote control (RC-1070).....                      | 1 |
| ⑧ R03/AAA batteries (for RC-1070).....                   | 2 |
| ⑨ FM indoor antenna .....                                | 1 |
| ⑩ AM loop antenna (small, for AM broadcasts) .....       | 1 |
| ⑪ AM loop antenna (large, for HD Radio broadcasts) ..... | 1 |
| ⑫ Dipole antenna (for HD Radio broadcasts) .....         | 1 |
| ⑬ Rod antenna for wireless LAN connection.....           | 1 |
| ⑭ Setup microphone (Cord length: Approx. 7.6 m).....     | 1 |

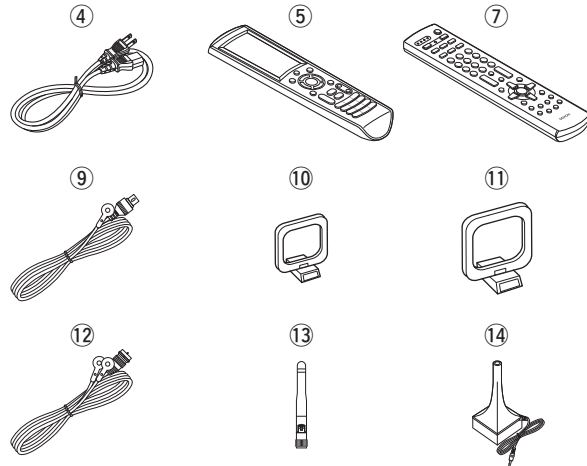

## Cautions on Handling

### • Before turning the power switch on

Check once again that all connections are correct and that there are no problems with the connection cables.

- Power is supplied to some of the circuitry even when the unit is set to the standby mode. When traveling or leaving home for long periods of time, be sure to unplug the power cord from the power outlet.

### • About condensation

If there is a major difference in temperature between the inside of the unit and the surroundings, condensation (dew) may form on the operating parts inside the unit, causing the unit not to operate properly.

If this happens, let the unit sit for an hour or two with the power turned off and wait until there is little difference in temperature before using the unit.

### • Cautions on using mobile phones

Using a mobile phone near this unit may result in noise. If so, move the mobile phone away from this unit when it is in use.

### • Moving the unit

Turn off the power and unplug the power cord from the power outlet.

Next, disconnect the connection cables to other system units before moving the unit.

- Note that the illustrations in these instructions may differ from the actual unit for explanation purposes.

- Light Emitting Diodes (LED) are used in the AVP-A1HDCI circuit. When powered on, a green light shows inside part of the AVP-A1HDCI, however this is not a fault.

## Cautions on Installation

### Note:

For proper heat dispersal, do not install this unit in a confined space, such as a bookcase or similar enclosure.

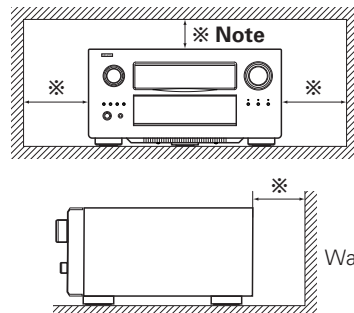

## About the Remote Control Unit

In addition to the AVP-A1HDCI, the included main remote control unit (RC-1067) can also be used to operate the equipment listed below.

- ① DENON system components
- ② Non-DENON system components
  - By setting the preset memory (☞ page 77 ~ 79)
  - By using the learn function (☞ page 80)

## Inserting the Batteries

- ① Lift the clasp and remove the rear lid.

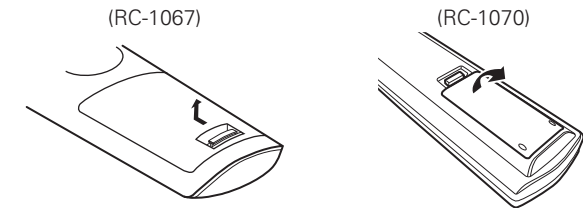

- ② Load the two batteries properly as indicated by the marks in the battery compartment.

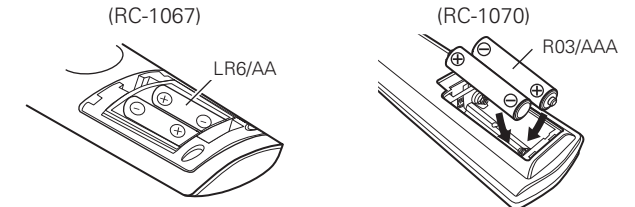

- ③ Put the rear cover back on.

## NOTE

- Replace the batteries with new ones if the set does not operate even when the remote control unit is operated close to the unit.
- The supplied batteries are only for verifying operation.
- When inserting the batteries, be sure to do so in the proper direction, following the “+” and “-” marks in the battery compartment.
- To prevent damage or leakage of battery fluid:
  - Do not use a new battery together with an old one.
  - Do not use two different types of batteries.
  - Do not attempt to charge dry batteries.
  - Do not short-circuit, disassemble, heat or dispose of batteries in flames.
- If the battery fluid should leak, carefully wipe the fluid off the inside of the battery compartment and insert new batteries.
- Remove the batteries from the remote control unit if it will not be in use for long periods.
- When replacing the batteries, have the new batteries ready and insert them as quickly as possible.

## Operating Range of the Remote Control Unit

Point the remote control unit at the remote sensor when operating it.

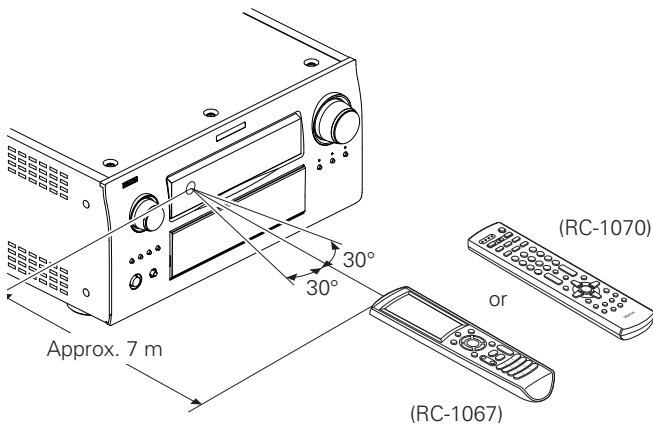

## NOTE

The set may function improperly or the remote control unit may not operate if the remote control sensor is exposed to direct sunlight, strong artificial light from an inverter type fluorescent lamp or infrared light.

## Part Names and Functions

For buttons not explained here, see the page indicated in parentheses ( ).

### Front Panel

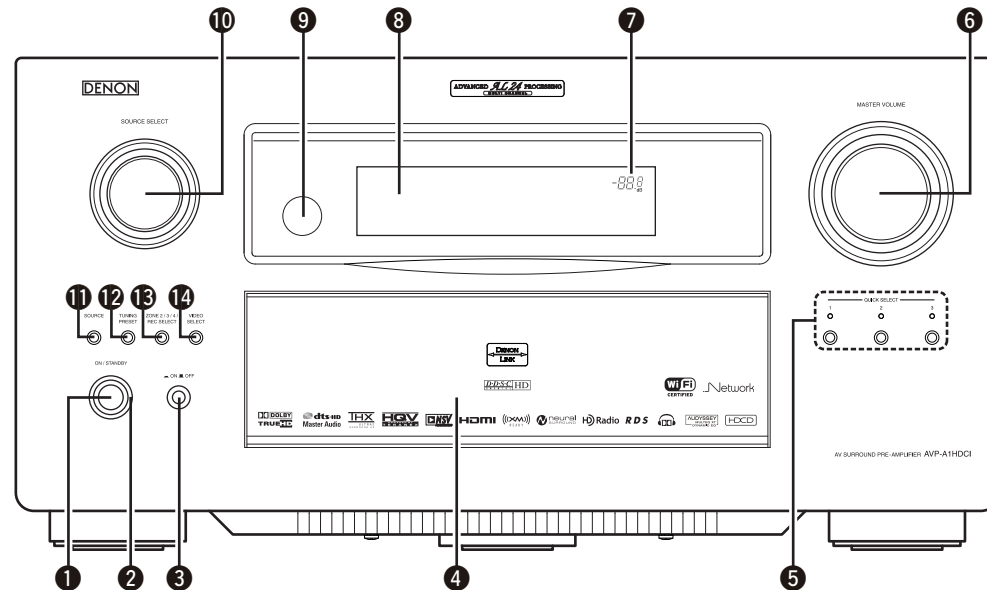

|   |      |  |          |
|---|------|--|----------|
| 1 Power operation button (ON/STANDBY) ..... | (58) | 8 Display .....                        | (5)      |
| 2 Power indicator .....                     | (58) | 9 Remote control sensor .....          | (4)      |
| 3 Power switch (ON/OFF) .....               | (58) | 10 SOURCE SELECT knob .....            | (45)     |
| 4 Door .....                                | (5)  | 11 SOURCE button .....                 | (45)     |
| 5 QUICK SELECT buttons / indicators .....   | (75) | 12 TUNING PRESET button .....          | (59)     |
| 6 MASTER VOLUME control knob .....          | (58) | 13 ZONE2/3/4 / REC SELECT button ..... | (73, 87) |
| 7 Master volume indicator .....             |      | 14 VIDEO SELECT button .....           | (46)     |

## [With the door open]

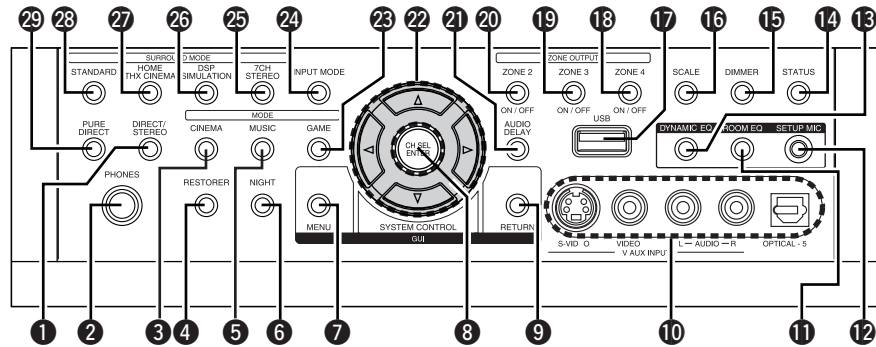

- |                            |                             |          |      |
|----------------------------|-----------------------------|----------|------|
| 1 DIRECT/STEREO button     | 16 SCALE button             | (51)     | (47) |
| 2 Headphones jack (PHONES) | 17 USB port                 | (58, 73) | (19) |
| 3 CINEMA button            | 18 ZONE4 ON/OFF button      | (50)     | (87) |
| 4 RESTORER button          | 19 ZONE3 ON/OFF button      | (55)     | (87) |
| 5 MUSIC button             | 20 ZONE2 ON/OFF button      | (50)     | (87) |
| 6 NIGHT button             | 21 AUDIO DELAY button       | (55)     | (56) |
| 7 MENU button              | 22 Cursor buttons (Δ ∇ ◀ ▶) | (24)     | (24) |
| 8 CH SEL / ENTER button    | 23 GAME button              | (24, 75) | (50) |
| 9 RETURN button            | 24 INPUT MODE button        | (24)     | (47) |
| 10 V.AUX INPUT connectors  | 25 7CH STEREO button        | (18)     | (51) |
| 11 ROOM EQ button          | 26 DSP SIMULATION button    | (55)     | (51) |
| 12 SETUP MIC jack          | 27 HOME THX CINEMA button   | (26)     | (50) |
| 13 DYNAMIC EQ button       | 28 STANDARD button          | (55)     | (51) |
| 14 STATUS button           | 29 PURE DIRECT button       | (57)     | (52) |
| 15 DIMMER button           |                             | (43)     |      |

## Display

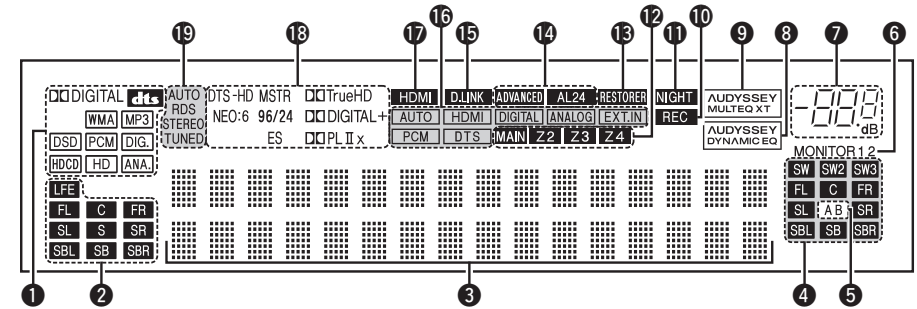

- |   |  |
|---|--|
| 1 Input signal indicators   | 13 RESTORER indicator  |
| 2 Input signal channel indicators   | This lights when the RESTORER mode is selected.  |
| 3 Information display   | 14 ADVANCED AL24 indicator   |
| The input source name, surround mode, setting values and other information are displayed here.  | This lights when Advanced AL24 Processing is activated (page 92).  |
| 4 Output signal channel indicators  | 15 D.LINK indicator  |
| 5 Surround speaker indicators   | This lights when playing using DENON LINK connections.   |
| These light according to the settings of the surround A and B speakers.   | 16 Input mode indicators   |
| 6 Monitor output indicators   | 17 HDMI indicator  |
| These light according to the HDMI monitor output setting. When set to "Auto (Dual)", the indicators light according to the connection status. | This lights when playing using HDMI connections.   |
| 7 Master volume indicator   | 18 Decoder indicators  |
| 8 AUDYSSEY DYNAMIC EQ indicator   | These light when the respective decoders are operating.  |
| This lights when the Dynamic EQ is selected.  | 19 Tuner reception mode indicators   |
| 9 AUDYSSEY MULTEQ XT indicator  | These light according to the reception conditions when the input source is set to "TUNER" or "HD Radio". |
| This lights when the room equalizer is selected.  | • AUTO   |
| 10 Recording output source indicator  | This lights when in the auto tuning mode.  |
| This lights when the REC OUT mode is selected.  | • RDS  |
| 11 NIGHT indicator  | These light when receiving RDS broadcasts.   |
| This lights when the night mode is selected.  | • STEREO   |
| 12 Multi zone indicators  | In the FM mode, this lights when receiving analog stereo broadcasts.                                     |
| These light when the power for the respective zone is turned on.  | • TUNED  |
|   | This lights when the broadcast is properly tuned in.   |

# Rear Panel

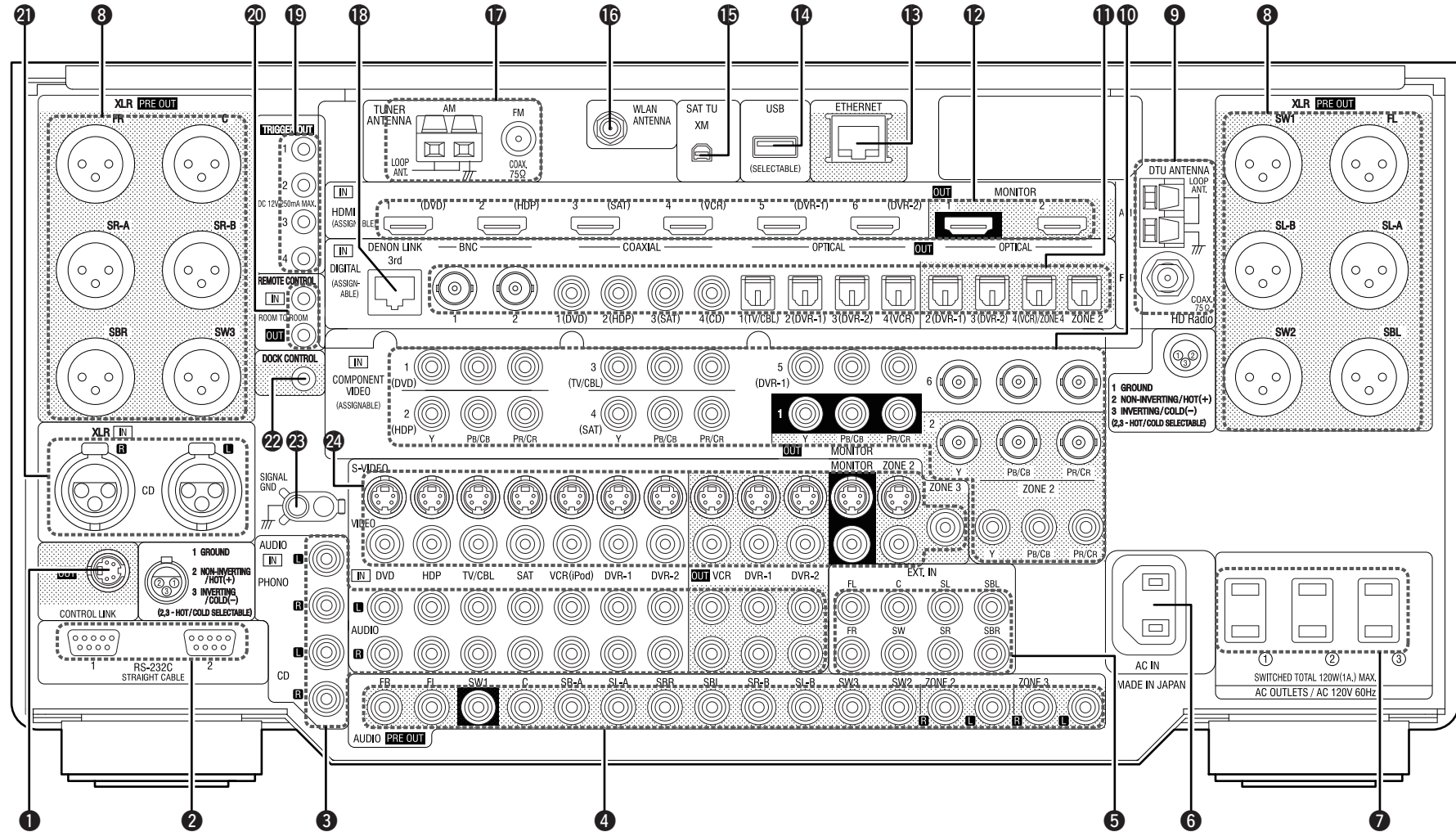

- |   |   |  |   |
|---|---|--|---|
| 1 CONTROL LINK connector..... (11)          | 8 XLR PRE OUT connectors..... (11)                                  | 13 ETHERNET connector..... (21)                      | 19 TRIGGER OUT jacks..... (23)          |
| 2 RS-232C connector..... (23)               | 9 HD Radio antenna terminals (DTU ANTENNA)..... (20)                | 14 USB port..... (19)                                | 20 REMOTE CONTROL jacks..... (22)       |
| 3 Analog audio connectors (AUDIO)..... (14) | 10 COMPONENT VIDEO connectors..... (13, 22)                         | 15 XM connector (SAT TU)..... (19)                   | 21 XLR audio connectors (CD)..... (14)  |
| 4 RCA PRE OUT connectors..... (11, 22)      | 11 Digital audio connectors (OPTICAL / COAXIAL / BNC)..... (13, 22) | 16 WLAN ANTENNA terminal..... (21)                   | 22 DOCK CONTROL jack..... (14)          |
| 5 EXT. IN connectors..... (18)              | 12 HDMI connectors..... (12)  | 17 FM/AM antenna terminals (TUNER ANTENNA)..... (20) | 23 SIGNAL GND terminal..... (14)        |
| 6 AC inlet (AC IN)..... (23)                |   | 18 DENON LINK connector..... (18)                    | 24 VIDEO / S-VIDEO connectors..... (13) |
| 7 AC OUTLETS..... (23)                      |   |  |   |



# Remote Control Unit

## □ Main remote control unit (RC-1067)

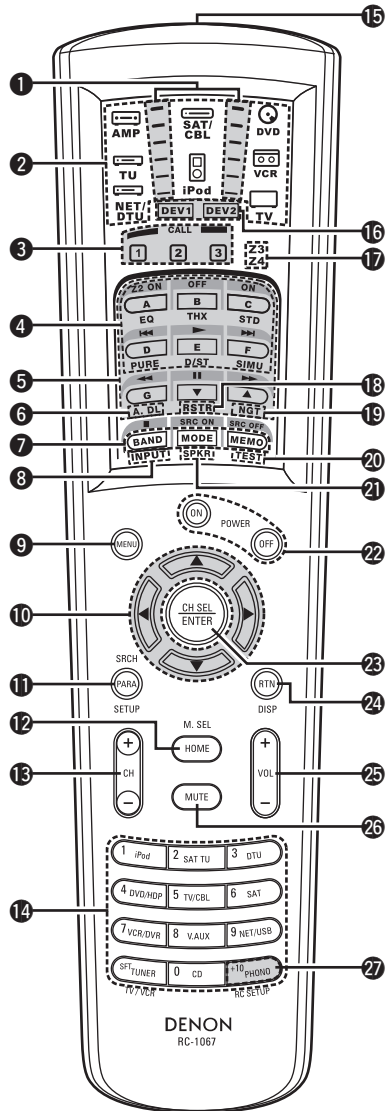

- 1 Signal transmission indicator ..... (77)
- 2 Mode select buttons ..... (77)
- 3 Quick select / System call buttons ..... (75, 81)
- 4 Surround mode buttons ..... (50 ~ 52)
- 5 System buttons ..... (78, 79)
- 6 Audio delay button (A. DL) ..... (56)
- 7 Tuner system buttons ..... (59, 79)
- 8 Input mode button (INPUT) ..... (47)
- 9 MENU button ..... (24)
- 10 Cursor buttons (Δ ∇ ◁ ▷) ..... (24)
- 11 Parameter / Search button (PARA / SRCH) ..... (52, 60, 62, 65)
- 12 Monitor select (M. SEL) / HOME button ..... (32, 77)
- 13 Channel buttons (CH) ..... (59, 65, 78)
- 14 Input source select / Number buttons ..... (45, 58)
- 15 Remote control signal transmitter ..... (4)
- 16 Device select indicators (DEV1 / DEV2) ... (77)
- 17 ZONE3 / ZONE4 select indicators (Z3 / Z4) ..... (87)
- 18 RESTORER button (RSTR) ..... (55)
- 19 Night button (NGT) ..... (55)
- 20 Test tone button (TEST) ..... (30)
- 21 Surround speaker select button (SPKR) ..... (31)
- 22 POWER buttons ..... (58)
- 23 Channel select (CH SEL) / ENTER button ..... (24, 75)
- 24 Return button (RTN) ..... (24)
- 25 Master volume control buttons (VOL) ..... (58)
- 26 Muting button (MUTE) ..... (58, 87)
- 27 Main remote control unit setup button (RC SETUP) ..... (77)



The time for which the backlight stays on can be changed (page 82 "Setting the Time the Backlight Stays Lit").

### NOTE

The ZONE2 mode **QUICK SELECT (1 ~ 3)**, **A. DL**, **RSTR**, **NGT**, **INPUT**, **SPKR**, **TEST** and surround mode buttons cannot be used.

## □ Sub remote control unit (RC-1070)

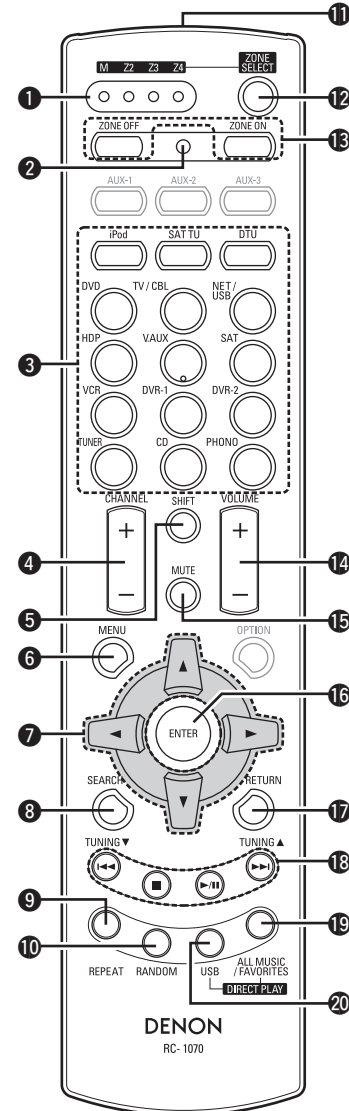

- 1 ZONE indicators ..... (85)
- 2 Advanced setup button ..... (85)
- 3 Input source select buttons ..... (45)
- 4 CHANNEL buttons ..... (65, 84)
- 5 SHIFT button ..... (59)
- 6 MENU button ..... (24)
- 7 Cursor buttons (Δ ∇ ◁ ▷) ..... (24)
- 8 SEARCH button ..... (60, 62, 65)
- 9 REPEAT button ..... (65)
- 10 RANDOM button ..... (65)
- 11 Remote control signal transmitter ..... (4)
- 12 ZONE SELECT button ..... (85)
- 13 Zone power on/off buttons (ZONE ON / ZONE OFF) ..... (87)
- 14 Master volume control buttons (VOLUME) ..... (58)
- 15 Muting button (MUTE) ..... (58, 87)
- 16 ENTER button ..... (24)
- 17 RETURN button ..... (24)
- 18 System buttons ..... (59, 83, 84)
- 19 ALL MUSIC/FAVORITES (DIRECT PLAY) button ..... (83)
- 20 USB (DIRECT PLAY) button ..... (83)

### NOTE

The **AUX-1**, **AUX-2**, **AUX-3** and **OPTION** buttons cannot be used.

# Connections

Connections for all compatible audio and video signal formats are described in these operating instructions. Please select the types of connections suited for the equipment you are connecting. With some types of connections, certain settings must be made on the AVP-A1HDCI. For details, refer to the instructions for the respective connection items below.











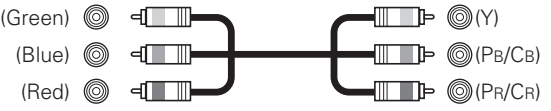





## NOTE

- Do not plug in the power cord until all connections have been completed.
- When making connections, also refer to the operating instructions of the other components.
- Be sure to connect the left and right channels properly (left with left, right with right).
- Do not bundle power cords together with connection cables. Doing so can result in humming or noise.

## Preparations

### Cables Used for Connections

Select the cables according to the equipment being connected.

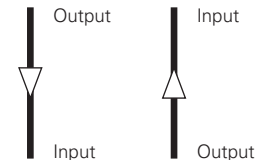
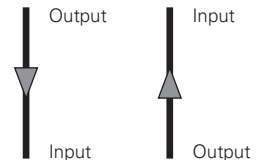
| Audio cables   | Video cables   |
|--|--|
| <p><b>Coaxial digital connections</b></p> <p>(Orange)  Coaxial digital (75 Ω/ohms pin-plug) cable</p>  | <p><b>Component video connections</b></p> <p>(Green)  (Y)<br/>(Blue)  (Pb/Cb)<br/>(Red)  (Pr/CR)</p> <p>Component video cable</p> |
| <p><b>Optical digital connections</b></p> <p> Optical cable</p>  | <p>(Green)  (Y)<br/>(Blue)  (Pb/Cb)<br/>(Red)  (Pr/CR)</p> <p>BNC (75 Ω/ohms) cable</p>   |
| <p><b>BNC digital connections</b></p> <p> BNC (75 Ω/ohms) cable</p>  | <p><b>S-Video connections</b></p> <p> S-Video cable</p>   |
| <p><b>Analog connections (XLR)</b></p> <p> Balanced cable</p>  | <p><b>Video connections</b></p> <p>(Yellow)  75 Ω/ohms pin-plug video cable</p>   |
| <p><b>Analog connections (stereo, RCA)</b></p> <p>(White)  (L)<br/>(Red)  (R)</p> <p>Stereo pin-plug cable</p> | <p style="text-align: center;"><b>Audio and video cables</b></p>   |
| <p><b>Analog connections (monaural, for subwoofer)</b></p> <p>(Black)  Pin-plug cable</p>  | <p><b>HDMI connections</b></p> <p> 19-pin HDMI cable</p>  |
| <p><b>DENON LINK connections</b></p> <p> DENON LINK cable</p>  | <p style="text-align: center;"><b>Signal direction</b></p>   |
| <p><b>Network connections (wired LAN)</b></p> <p> Ethernet cable</p>   | <p>Audio signal: </p> <p>Video signal: </p>  |



## Video Conversion Function

- This function automatically converts various formats of video signals input to the AVP-A1HDCI into the format used to output the video signals from the AVP-A1HDCI to a monitor.
- The AVP-A1HDCI's video input/output circuitry is compatible with the following four types of video signals:

Digital video signals: HDMI

Analog video signals: Component video, S-Video and Video

### [Flow of video signals inside the AVP-A1HDCI]

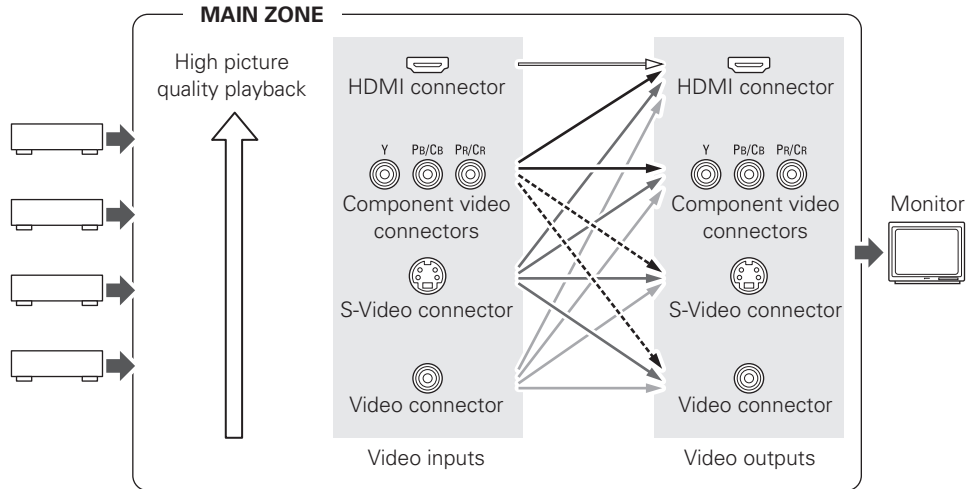

----- : When 480i/576i signals are input

### [Flow of video signals for ZONE2]

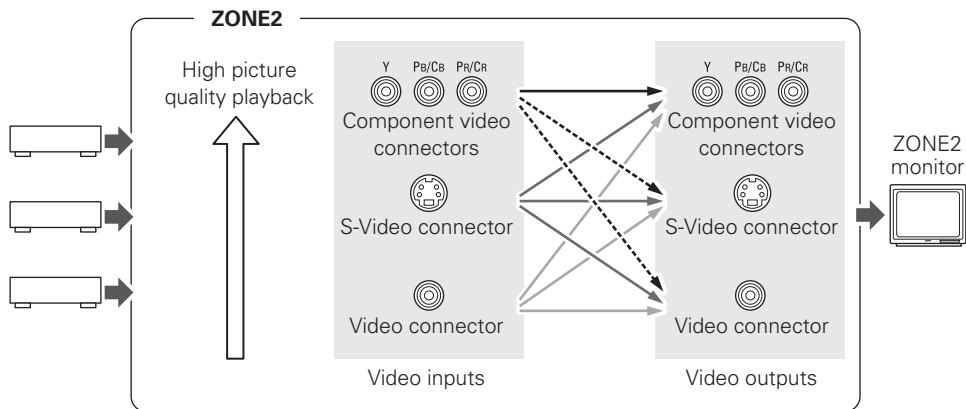

----- : When 480i/576i signals are input

### [Flow of video signals for ZONE3]

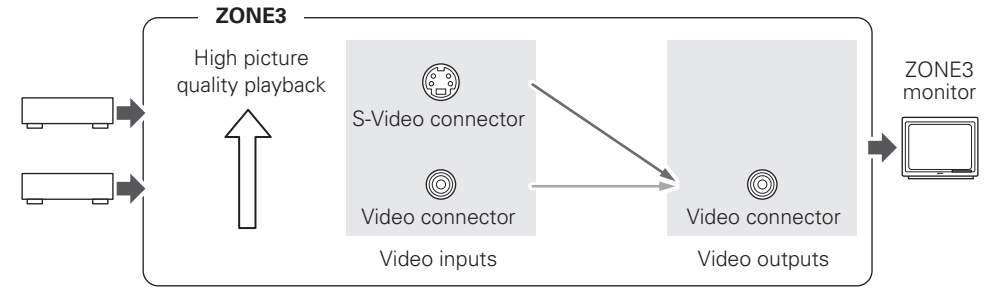

- When not using this function, connect a monitor output with the same type of connector as the video input connector.
- The resolution of the HDMI input-compatible monitor connected to the AVP-A1HDCI can be checked at GUI menu "Information" - "HDMI Information" - "Monitor1" or "Monitor2" (page 57).

#### NOTE

- For optimum video performance, THX recommends that you set the conversion mode to "OFF" to use video signals pass through system without up conversion.
- Example:** View video input from a component video on the component video monitor.
- HDMI signals cannot be converted into analog signals.
- 1080p component input video signals cannot be output to anything other than component video connectors.
- 480p/576p, 1080i and 720p component video input signals cannot be converted into S-Video or Video format.
- When a non-standard video signal from a game machine or some other source is input, the video conversion function might not operate.

## Speaker Layout

The illustration below shows a basic example of installation of the amplifier combined with 8 speakers and a monitor.

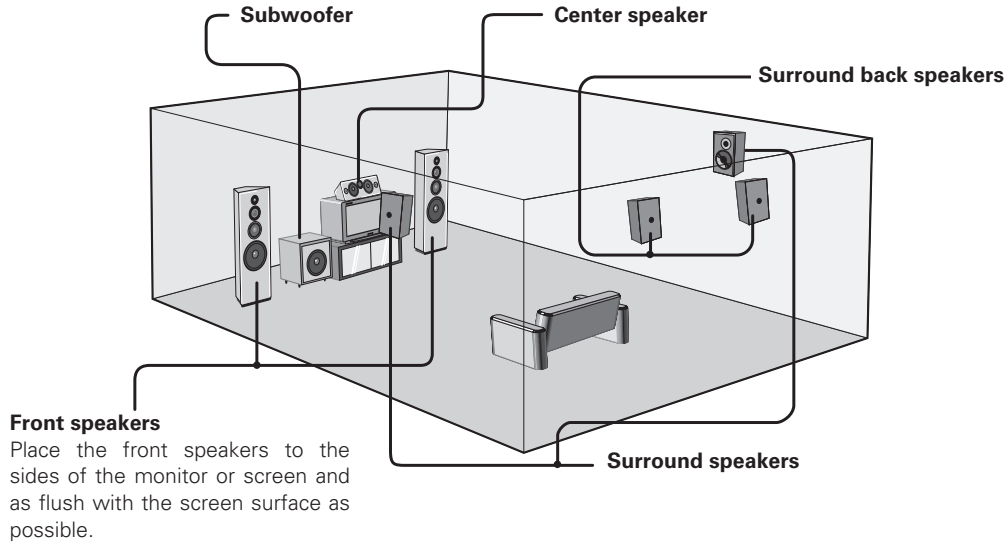

Two surround back speakers are required to use the THX Ultra2 Cinema, THX Music mode and THX Games mode.

Set the surround back speakers so that the distance to the listening position is the same for both the left and right speakers. It is also recommended that the deviations of the distance from the listening position to L and R channel speakers (front left (FL) and front right (FR), surround left (SL) and surround right (SR), surround back left (SBL) and surround back right (SBR)) is less than 2 ft (60 cm).



The table below shows a typical speaker configuration for the AVP-A1HDCI.

|              | FRONT |   | CENTER | SURROUND A |   | SURROUND B |   | SURROUND BACK |   |        | SUBWOOFER (※) |
|--------------|-------|---|--------|------------|---|------------|---|---------------|---|--------|---------------|
|              | L     | R |        | L          | R | L          | R | L             | R | 1 only |               |
| 9.1-channels | ○     | ○ | ○      | ○          | ○ | ○          | ○ | ○             | ○ | -      | ○             |
| 7.1-channels | ○     | ○ | ○      | ○          | ○ | -          | - | ○             | ○ | -      | ○             |
| 6.1-channels | ○     | ○ | ○      | ○          | ○ | -          | - | -             | - | ○      | ○             |
| 5.1-channels | ○     | ○ | ○      | ○          | ○ | -          | - | -             | - | -      | ○             |
| 3.1-channels | ○     | ○ | ○      | -          | - | -          | - | -             | - | -      | ○             |
| 2.1-channels | ○     | ○ | -      | -          | - | -          | - | -             | - | -      | ○             |
| 2-channels   | ○     | ○ | -      | -          | - | -          | - | -             | - | -      | -             |

※ The AVP-A1HDCI can be connected to a maximum of 3 subwoofers.

## Connecting to the Power Amp

- Connect the AVP-A1HDCI pre-out terminal to the power amp (sold separately).
- AVP-A1HDCI has a RCA pre-out terminal and XLR pre-out terminal. Connect accordingly with the power amp you want to use.
- The polarity of the XLR pre-out terminal can be switched using GUI menu “Manual Setup” – “Option Setup” – “XLR Out Polarity” (☞ page 41).
- Connect the speakers to the power amp.
- Refer to the owner’s manual of each piece of equipment when making connections.

## POA-A1HDCI Connection and Operation

- When connecting the AVP-A1HDCI to the power amp POA-A1HDCI with a control link cable (included with the POA-A1HDCI), you can perform the following control operations.
  - POA-A1HDCI channel input selection and power amp settings
  - Link POA-A1HDCI to AVP-A1HDCI On/Standby control
  - Link POA-A1HDCI meter operation to AVP-A1HDCI display on/off control (☞ page 43)
  - Updating POA-A1HDCI firmware (☞ page 43)
- Up to 2 POA-A1HDCI units can be connected. Refer to the POA-A1HDCI owner’s manual for making connections and POA-A1HDCI settings.



- For instructions for connecting speakers, please refer to the POA-A1HDCI owner’s manual.
- When using just one surround back speaker, connect it to the left channel (SBL).

## Connections

✎ When using Subwoofer 2 or 3, set GUI menu “Manual Setup” – “Speaker Setup” – “Subwoofer Setup” (page 29).

### ❑ Connecting the RCA pre-out terminal (Example : 9.3-channels)

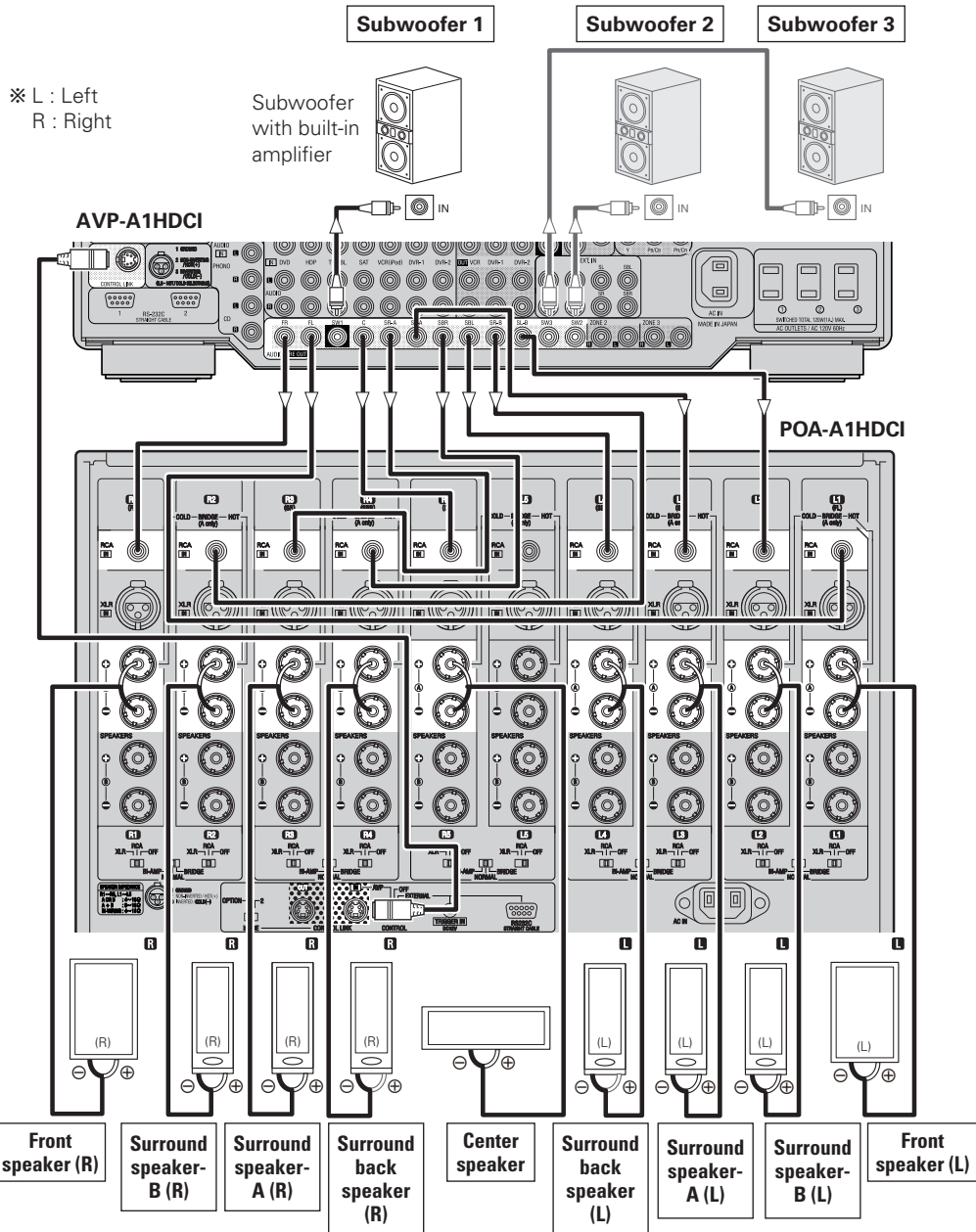

### ❑ Connecting the XLR pre-out terminal (Example : 9.3-channels)

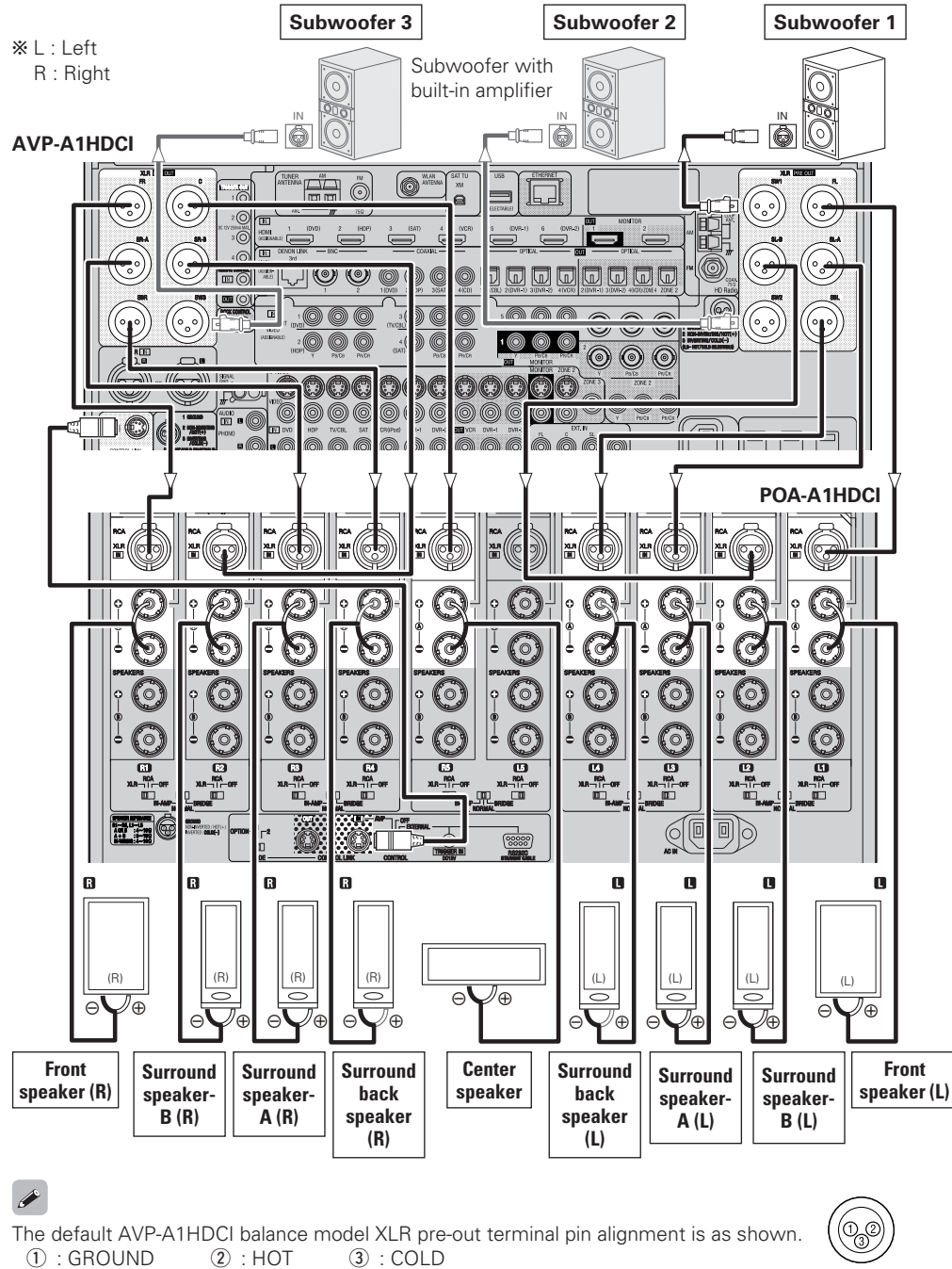

## Operations

### 1 Connect AVP-A1HDCI and POA-A1HDCI with the control link cable.

- ※ The control link cable is included with the POA-A1HDCI.
- ※ AVP-A1HDCI can be connected and control to up to 2 POA-A1HDCI units.
- Refer to the POA-A1HDCI user's manual for how to connect.

### 2 Set the POA-A1HDCI's control selector switch to "AVP".

### 3 Set the POA-A1HDCI's mode select switch according to the number of POA-A1HDCI units you are connecting.

- When connecting 1 unit : "1"
- When connecting 2 units : 1st unit "1", 2nd unit "2"

- ※ Refer to the POA-A1HDCI owner's manual for details.

### 4 Switch the AVP-A1HDCI and POA-A1HDCI power on.

### 5 Depending on the number of POA-A1HDCI units to be connected, set GUI menu "Option Setup" – "POA Setting" – "POA LINK" to either "ON (Single)" or "ON (Dual)" (☞ page 41).

### 6 Use GUI menu "Option Setup" – "POA Setting" – "LINK Check" to check the connection.

## Connecting Equipment with HDMI connectors

With HDMI connections, the video and audio signals can be transferred with a single cable.

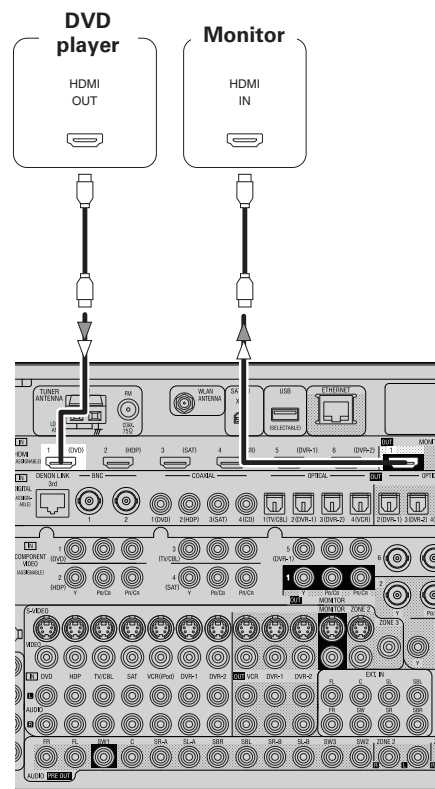

- By default, HDMI sound is output from the speaker of the power amp connected to AVP-A1HDCI.
- To output the sound from the TV, make the settings at GUI menu "Manual Setup" – "HDMI Setup" – "Audio" – "TV" (☞ page 32).

- ※ The AVP-A1HDCI is supported to the feature of HDMI listed below.
  - 30 and 36 bit Deep Color
  - xvYCC
  - Auto Lipsync Correction

| Compatible audio format                        | Details                         | Discs (examples)            |
|--|---------------------------------|-----------------------------|
| 2-channel linear PCM                           | 2ch 32-192 kHz<br>16/20/24 bits | CD, DVD-Video,<br>DVD-Audio |
| Multi-channel linear PCM                       | 8ch 32-192 kHz<br>16/20/24 bits | DVD-Audio                   |
| Dolby Digital, DTS                             | Bitstream                       | DVD-Video                   |
| DSD  | 2/5.1ch<br>2.8224 MHz<br>1 bit  | SACD                        |
| Dolby Digital Plus,<br>Dolby TrueHD,<br>DTS-HD | Bitstream                       | HD DVD,<br>Blu-ray Disc     |

### Copyright protection system (HDCP)

In order to play the digital video and audio signals of a DVD-Video or DVD-Audio disc using HDMI/DVI connections, both the connected DVD player and monitor must be equipped for a copyright protection system called "HDCP" (High-bandwidth Digital Content Protection). HDCP is a copy protection technology consisting of data encoding and mutual identification of the devices. The AVP-A1HDCI is HDCP-compatible. For details on the DVD player or monitor you are using, refer to its operating instructions.

### When connecting with an HDMI/DVI converter cable (adapter)

- HDMI video signals are theoretically compatible with the DVI format. When connecting to a monitor, etc., equipped with a DVI-D connector, connection is possible using an HDMI/DVI converter cable, but depending on the combination of components in some cases the video signals will not be output.
- When connecting using an HDMI/DVI converter adapter, the video signals may not be output properly due to poor connections with the connected cable, etc.

**NOTE**

- Use a CPPM-compatible DVD player to play DVD-Audio discs that are copyright-protected by CPPM.
- The audio signals output from the HDMI connector (sampling frequency, bit rate, etc.) may be restricted by the connected device.
- Video signals are not output properly when using devices that are not HDCP-compatible.
- Video signals are not output if the input video signals do not match the monitor's resolution. In this case, switch the DVD player's resolution to a resolution with which the monitor is compatible.
- If the GUI menu "Manual Setup" – "HDMI Setup" – "Audio" setting (page 32) is set to "Amp", the sound may be interrupted when the monitor's power is turned off.
- Use a cable on which the HDMI logo is indicated (a certified HDMI product) for connection to the HDMI connector. Normal playback may not be possible when using a cable other than one on which the HDMI logo is indicated (a non-HDMI-certified product).
- If the monitor or DVD player does not support Deep Color, Deep Color signal transfer is not possible.
- If the monitor or DVD player does not support xvYCC, xvYCC signal transfer is not possible.
- If the monitor does not support "Auto Lipsync Correction" function, this function will not work.
- The AVP-A1HDCI is compatible with the HDMI's CEC (Consumer Electronics Control) function. Please note the following.
  - It may not work depending on the device it is connected to and its setup.
  - It does not operate with televisions or players that are not compatible with HDMI's CEC.



- When the AVP-A1HDCI and DVD player are connected using an HDMI cable, also connect the AVP-A1HDCI and monitor using an HDMI cable.
- If the connected monitor or DVD player only has a DVI-D connector, use an HDMI/DVI converter cable. When using a DVI cable, no audio signals are transmitted.
- Use a Deep Color compatible cable for connection to Deep Color compatible devices.

**Connecting the Monitor**

- Connect the cables to be used (page 9 "Video Conversion Function").
- With HDMI connections, the video and audio signals can be transferred with a single cable.
- To output the audio signals to the monitor with HDMI connections, set GUI menu "Manual Setup" – "HDMI Setup" – "Audio" to "TV" (page 32).

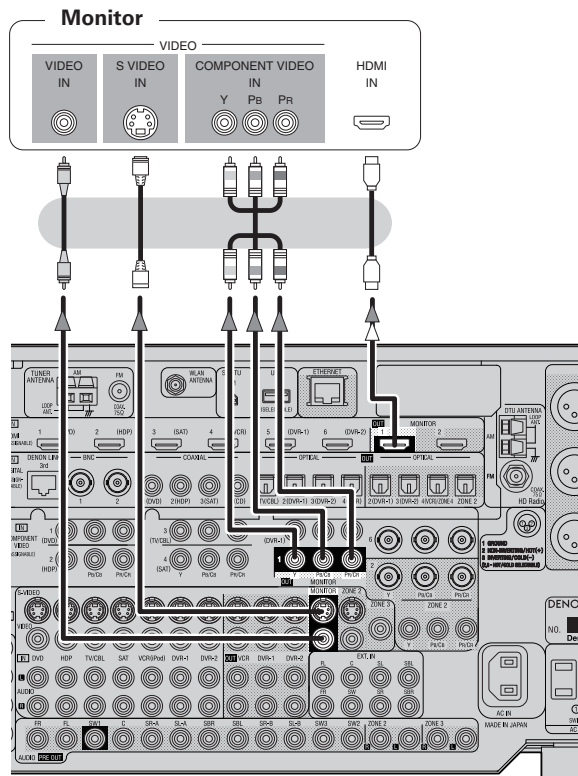

**NOTE**

- The component video connectors may be indicated differently on your monitor. For details, see the monitor's operating instructions.
- The audio signals output from the HDMI connectors are only the HDMI input signals.

**Connecting the Playback Components**

Carefully check the left (L) and right (R) channels and the inputs and outputs, and be sure to interconnect correctly.

**DVD Player**

- Connect the cables to be used.
- With HDMI connections, the video and audio signals can be transferred with a single cable.

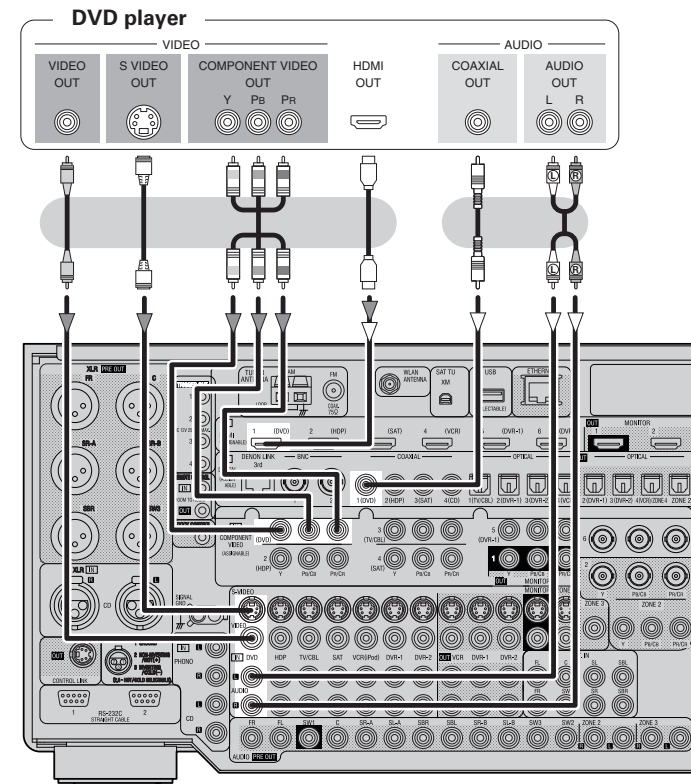

- Connect an HDP (High-Definition Player) in the same way.
- When using an optical cable or a BNC cable for the digital audio connection, make the settings at GUI menu "Source Select" – "DVD" – "Assign" – "Digital" (page 48).
- When using a BNC cable for the component video connection, make the settings at GUI menu "Source Select" – "DVD" – "Assign" – "Component" (page 48).



## Record Player

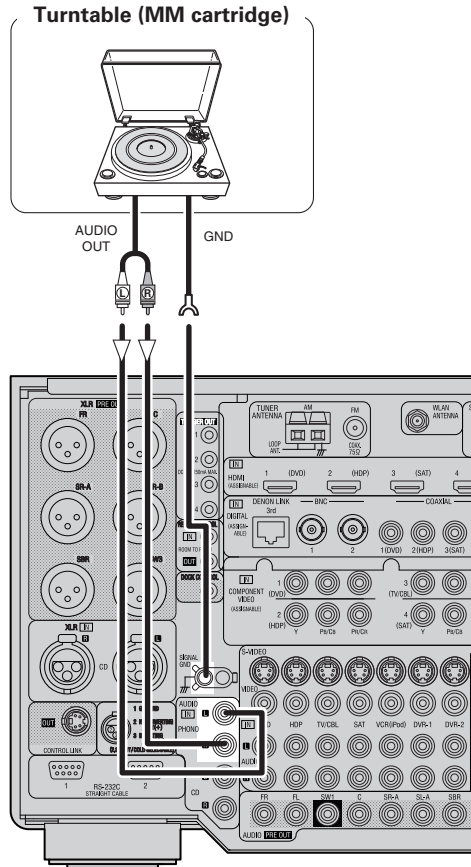

- When connecting a record player with an MC cartridge, use a commercially available MC head amplifier or a step-up transformer.
- Induction humming (a booming sound) may be produced from the speakers if the volume is raised with no record player connected.
- With some record players, noise may be generated when the ground wire is connected. If so, disconnect the ground wire.

### NOTE

The AVP-A1HDCI's SIGNAL GND terminal is meant to reduce noise when a record player is connected. This is not a safety ground terminal.

## CD Player

Connect the cables to be used.

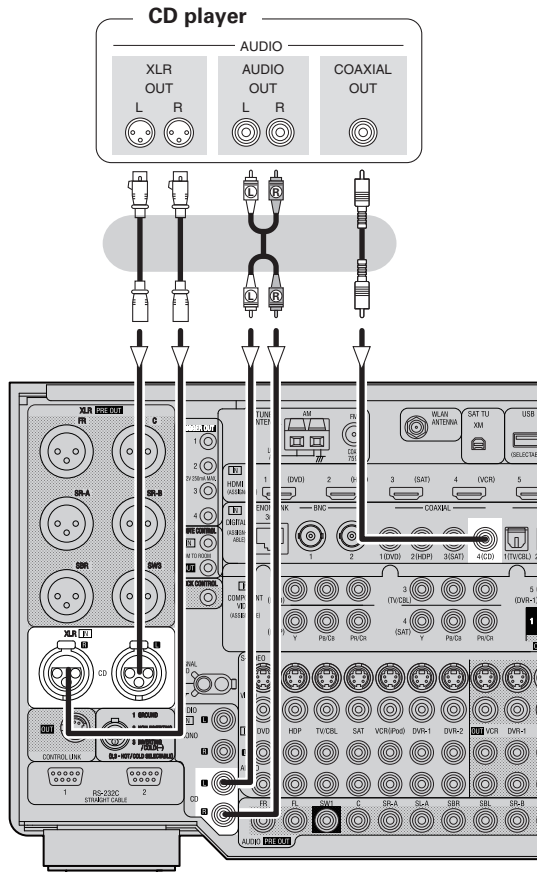

- When using an optical cable or a BNC cable for the digital audio connection, make the settings at GUI menu "Source Select" – "CD" – "Assign" – "Digital" (page 48).
- The default analog audio input setting is "RCA". When using a balanced cable for the analog audio connection, make the settings at GUI menu "Source Select" – "CD" – "Assign" – "Analog" (page 49).

### NOTE

The default AVP-A1HDCI balance model XLR input connectors pin alignment is as shown.

- ① : GROUND
- ② : HOT
- ③ : COLD



## iPod®

Use a DENON Control Dock for iPod (ASD-1R, sold separately) to connect the iPod to the AVP-A1HDCI. For instructions on the Control Dock for iPod settings, refer to the Control Dock for iPod's operating instructions.

Example :

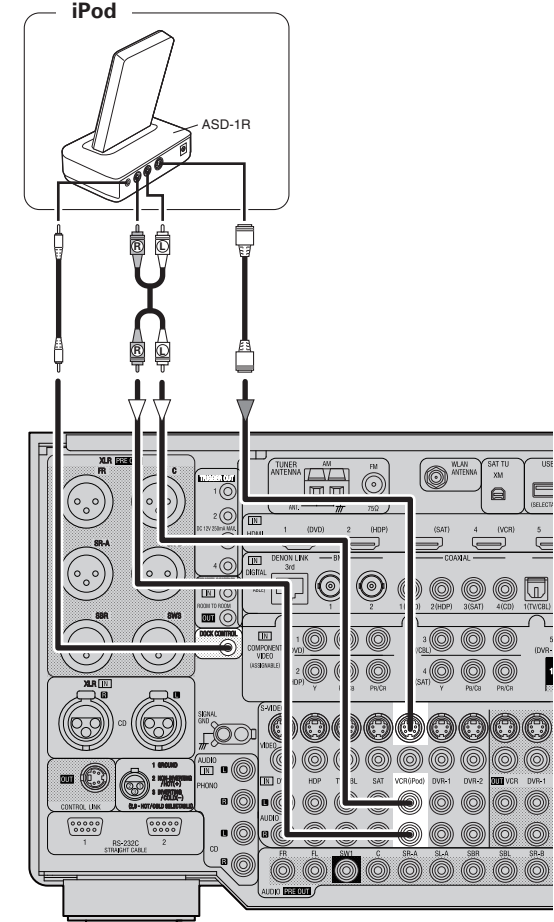

- With the default settings, the iPod can be used connected to the VCR (iPod) connector.
- To assign the iPod to a connector other than VCR (iPod), make the settings at GUI menu "Source Select" – "(input source to which iPod dock assigned)" – "Assign" – "iPod dock" (page 49).

## TV/CABLE Tuner

Connect the cables to be used.

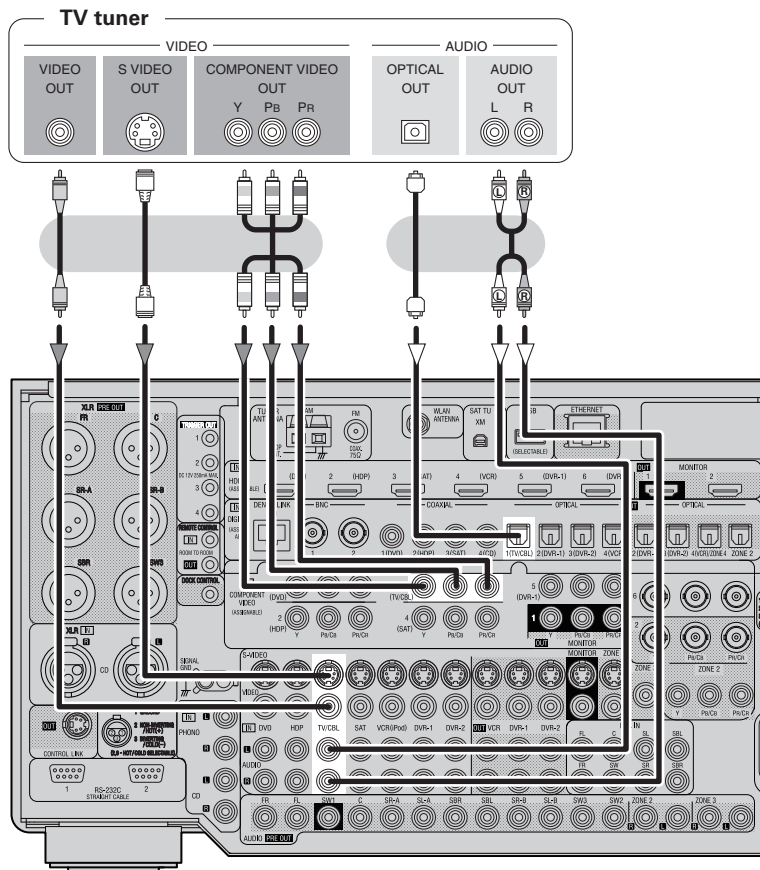

- When using a coaxial digital cable or a BNC cable for the digital audio connection, make the settings at GUI menu "Source Select" – "TV/CBL" – "Assign" – "Digital" (page 48).
- When using a BNC cable for the component video connection, make the settings at GUI menu "Source Select" – "TV/CBL" – "Assign" – "Component" (page 48).

## Satellite Receiver

Connect the cables to be used.

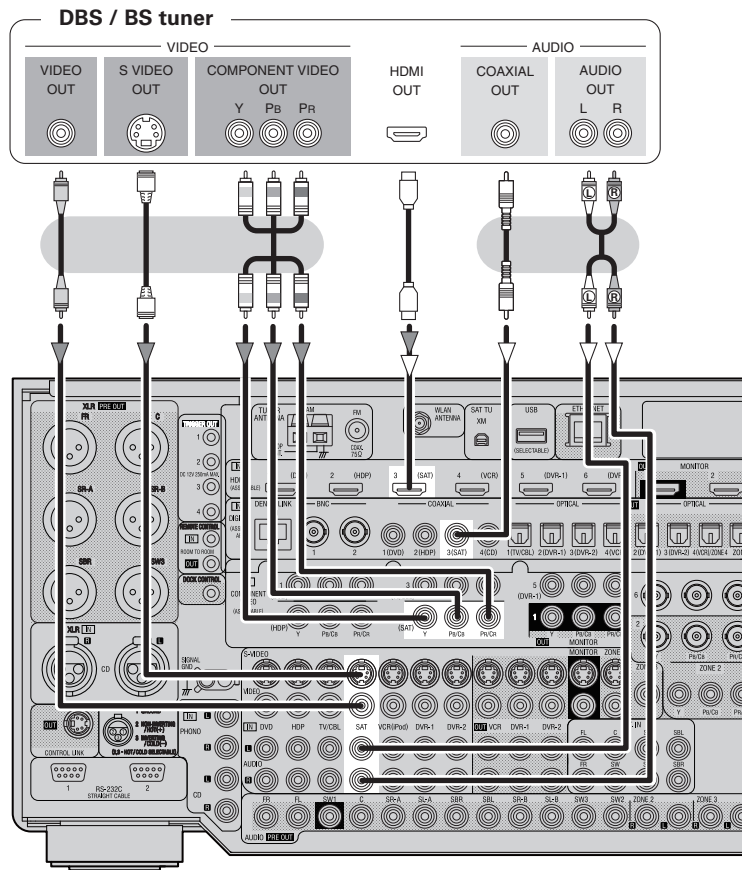

- When using an optical cable or a BNC cable for the digital audio connection, make the settings at GUI menu "Source Select" – "SAT" – "Assign" – "Digital" (page 48).
- When using a BNC cable for the component video connection, make the settings at GUI menu "Source Select" – "SAT" – "Assign" – "Component" (page 48).



# Connecting the Recording Components

Carefully check the left (L) and right (R) channels and the inputs and outputs, and be sure to interconnect correctly.

## Digital Video Recorder

Connect the cables to be used.

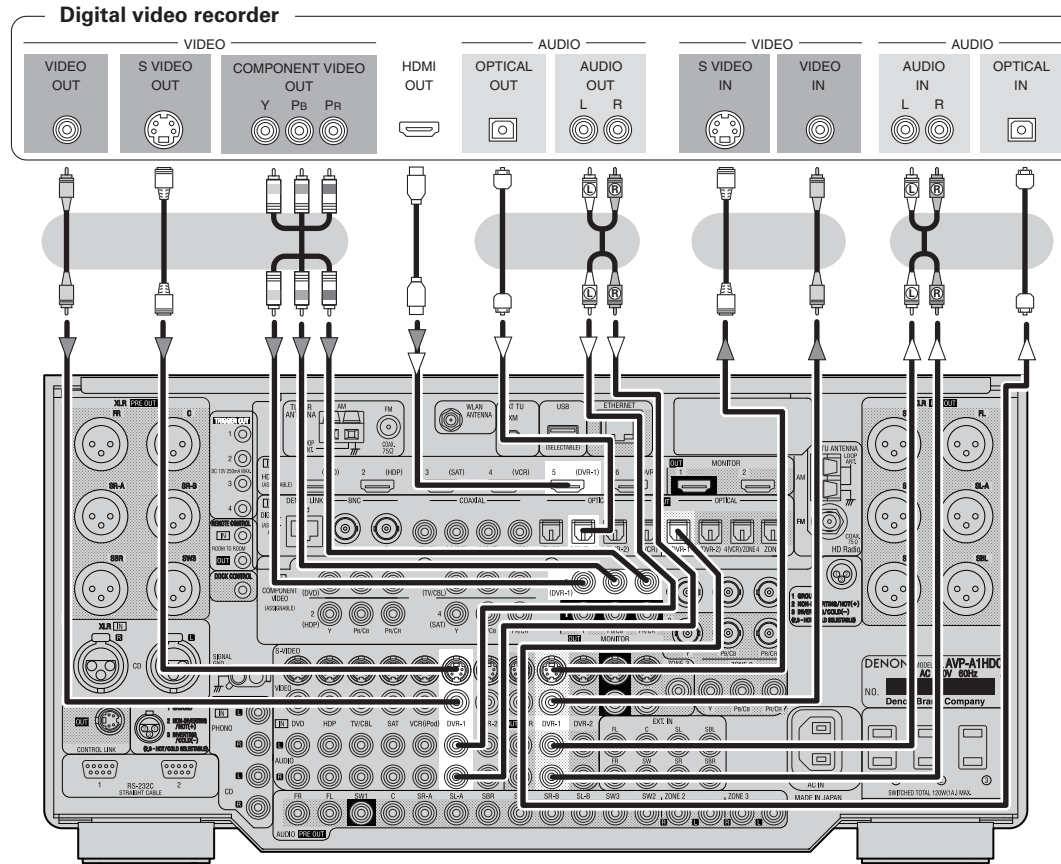

- Make analog connections if you wish to record analog audio signals.
- When recording to a digital video recorder, it is necessary that the type of cable used with the playback source equipment be the same type that is connected to the AVP-A1HDCI DVR-1 OUT connector.  
**Example:** TV IN → S-Video cable : DVR-1 OUT → S-Video cable  
TV IN → Video cable : DVR-1 OUT → Video cable

- Connect a DVR-2 in the same way.
- When using a component video cable or a BNC cable for the component video connection make the settings at GUI menu "Source Select" – "DVR-1" or "DVR-2" – "Assign" – "Component" (page 48).

### NOTE

- Do not connect the output of the component connected to the AVP-A1HDCI's OPTICAL2 output connector to any input connector other than OPTICAL2.
- Do not connect the output of the component connected to the AVP-A1HDCI's OPTICAL3 output connector to any input connector other than OPTICAL3.

## Video Cassette Recorder

Connect the cables to be used.

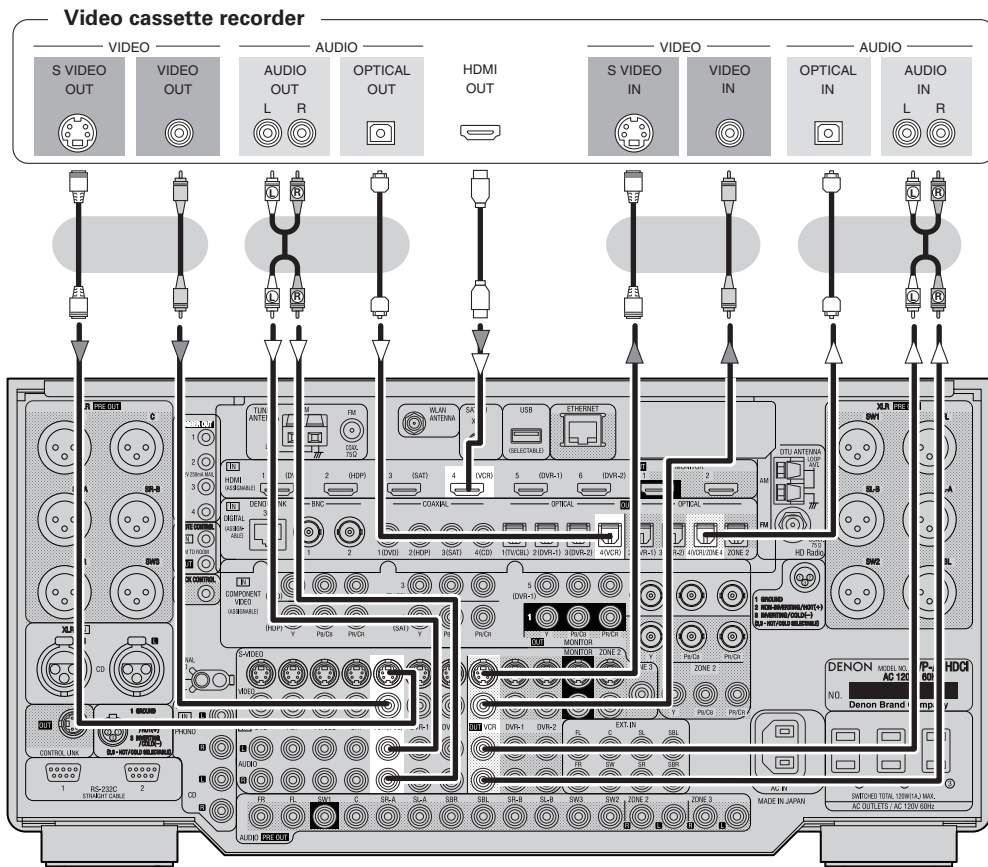

- When recording to a VCR, it is necessary that the type of cable used with the playback source equipment be the same type that is connected to the AVP-A1HDCI's VCR OUT connector.  
**Example:** TV IN → S-Video cable : VCR OUT → S-Video cable  
 TV IN → Video cable : VCR OUT → Video cable
- When using a component video cable or a BNC cable for the video connection, make the settings at GUI menu "Source Select" – "VCR" – "Assign" – "Component" (page 48).

### NOTE

Do not connect the output of the component connected to the AVP-A1HDCI's OPTICAL4 output connector to any input connector other than OPTICAL4.

## CD Recorder / MD Recorder / Tape Deck

Make analog connections if you wish to record analog audio signals, or digital connections if you wish to record digital audio signals, depending on the types of connectors on the components being used.

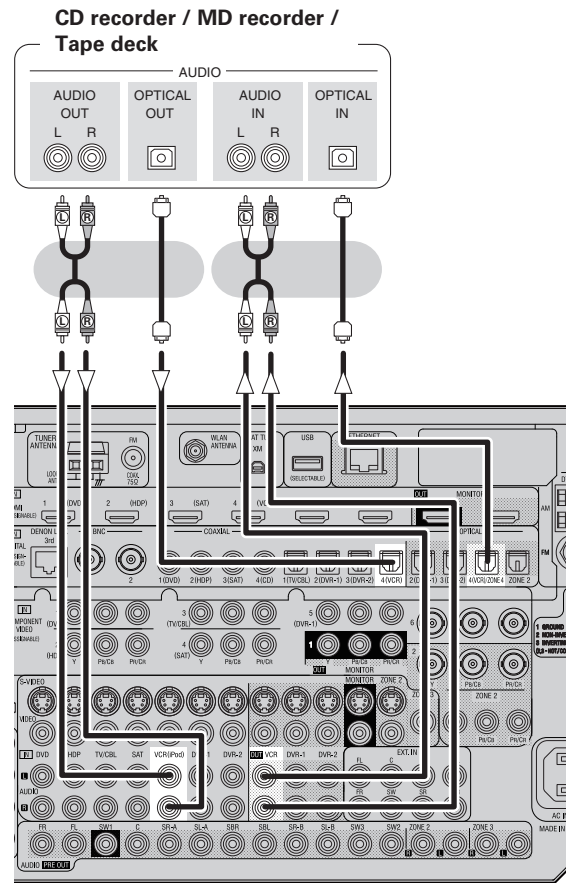

### NOTE

Do not connect the output of the component connected to the AVP-A1HDCI's OPTICAL4 output connector to any input connector other than OPTICAL4.

## Connections to Other Devices

Carefully check the left (L) and right (R) channels and the inputs and outputs, and be sure to interconnect correctly.

### Components Equipped with a DENON LINK connector

Multi-channel playback is possible with DVD-Audio discs, Super Audio CD, etc.

#### DVD player AUDIO DENON LINK

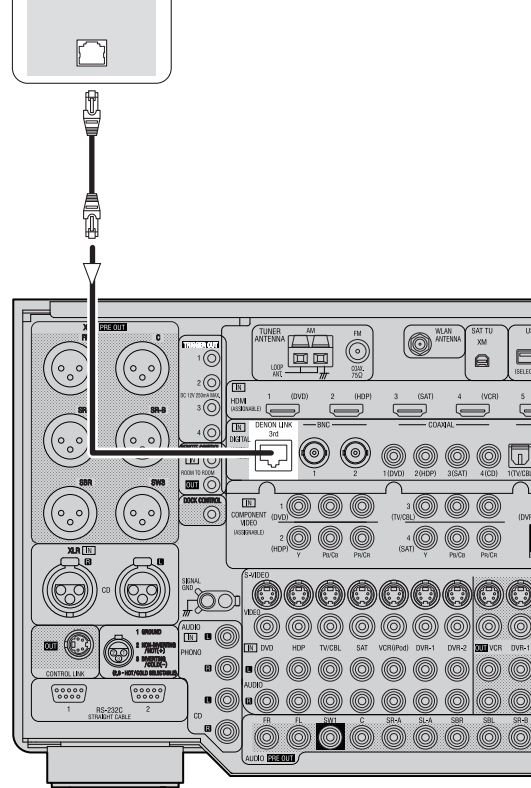

To use with DENON LINK connections, make the settings at GUI menu "Source Select" – "(input source)" – "Assign" – "Digital" – "DENON LINK" (☞ page 48).

## Video Camera / Game Console

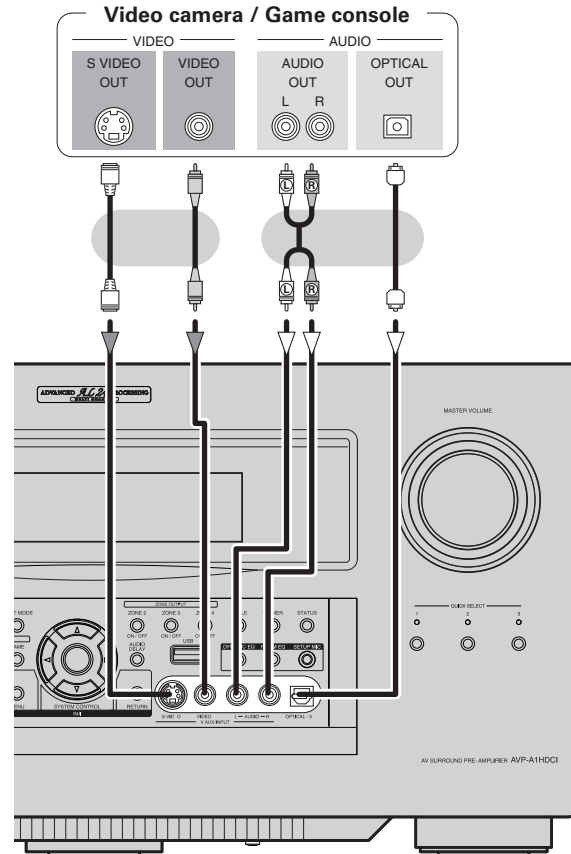

## Component with Multi-channel Output connectors

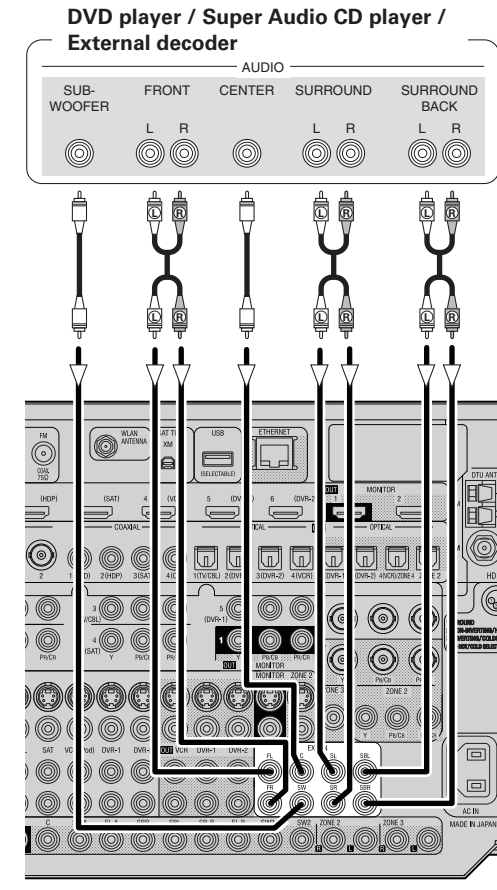

- To play the analog input signals input to the EXT. IN connectors, press the **INPUT MODE** button on the main unit or **INPUT** button on the main remote control unit and select "EXT. IN" or make the settings at GUI menu "Source Select" – "(input source)" – "Input Mode" – "Input Mode" – "EXT. IN" (☞ page 47).
- The video signal can be connected in the same way as a DVD player (☞ page 13).
- To play copyright-protected discs, connect the AVP-A1HDCI's EXT. IN connector with the DVD player's analog multi-channel output connector.

## USB Port

### Front panel

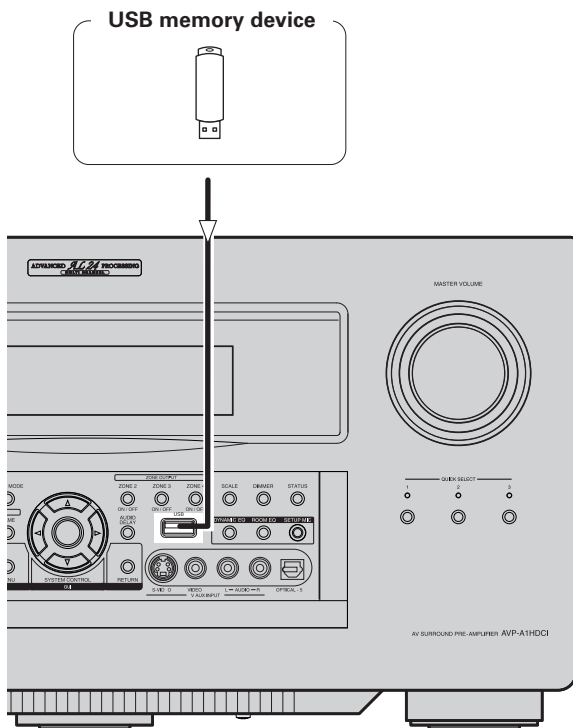

### Rear panel

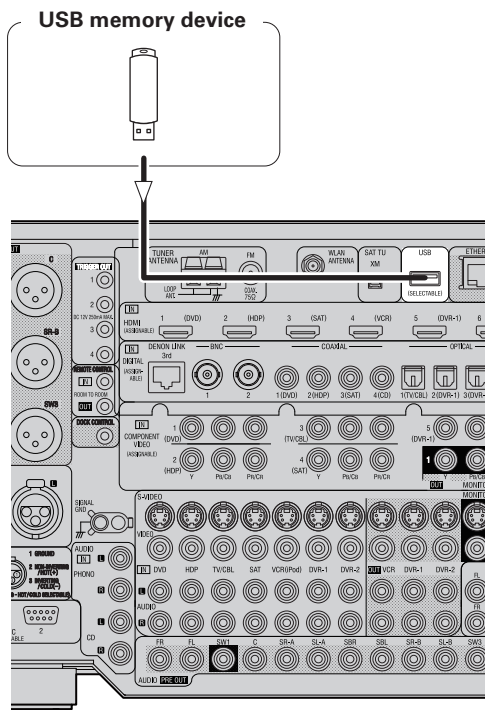

- In the initial status, USB memory devices can be used by connecting them to the USB port on the front panel.
- To change the port to be used, see “USB Select” on page 49.
- For instructions on playing the files on a USB memory device, see page 69, 70.

### NOTE

- Set to the USB port you want to use.
- The AVP-A1HDCI is equipped with two USB ports, one each on the front and rear panels. It is not possible to use the set with USB memory devices connected to both the ports at the same time. Select the USB port you want to use at the GUI menu “Source Select” – “NET/USB” – “Playback Mode” – “USB Select”.
- Do not use the extension cable for connecting the USB memory device to the AVP-A1HDCI’s USB port. Use of the extension cable may cause harmful interference.

## XM Connector

- The AVP-A1HDCI is an XM Ready® receiver. You can receive XM® Satellite Radio by connecting to the XM Mini-Tuner and Home Dock (includes home antenna, each sold separately) and subscribing to the XM service.
  - Plug the XM Mini-Tuner and Home Dock into the XM connector on the rear panel.
  - Position the Home Dock antenna near a south-facing window to receive the best signal.
- For details, see “Listening to XM Satellite Radio Programs” (page 61).
- When making connections, also refer to the operating instructions of the XM Mini-Tuner and Home Dock.

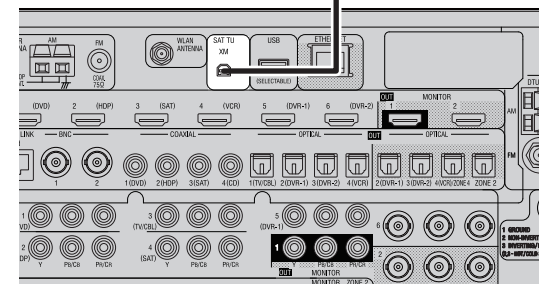
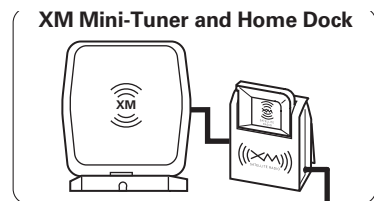

### NOTE

Keep the power cord unplugged until the XM Mini-Tuner and Home Dock connection have been completed.

- The XM name and related logo are registered trademarks of XM Satellite Radio Inc. All rights reserved.
- XM Ready is a registered trademark of XM Satellite Radio Inc. All rights reserved.

## Antenna terminals

An F-type FM antenna cable plug can be connected directly.

### AM/FM

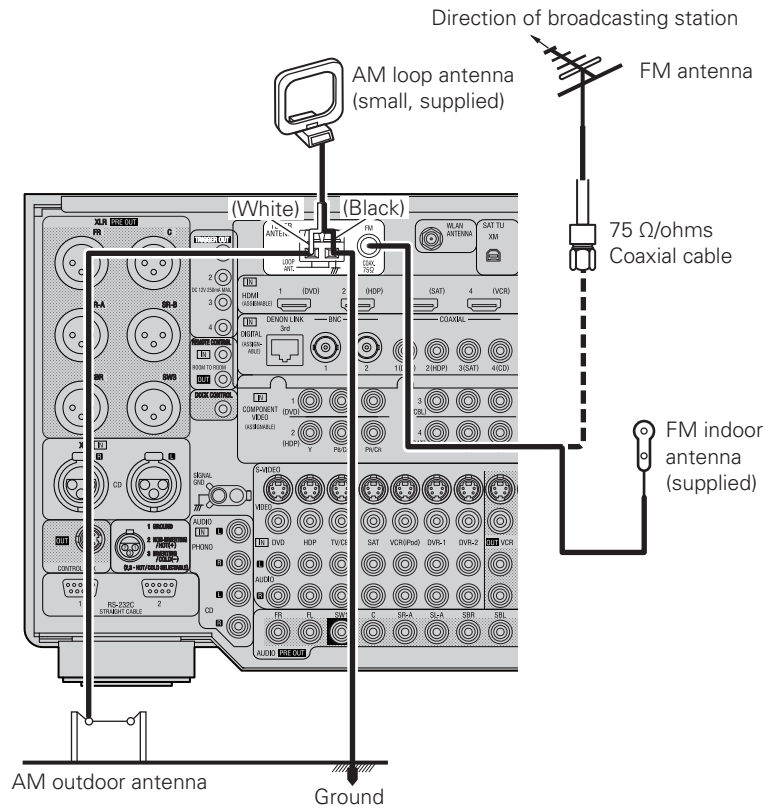

## HD Radio™ broadcast

HD Radio broadcast is a service that is only available within the United States.

Direction of broadcasting station

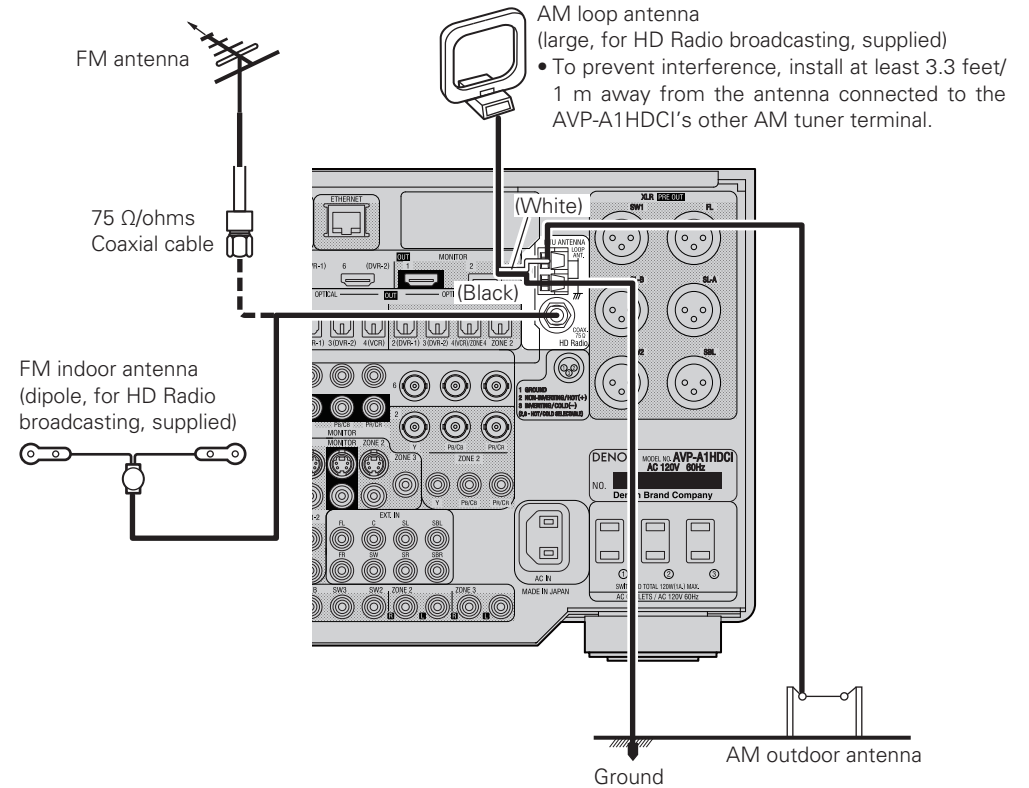

#### Note to CATV system installer:

This reminder is provided to call the CATV system installer's attention to Article 820-40 of the NEC which provides guidelines for proper grounding and, in particular, specifies that the cable ground shall be connected to the grounding system of the building, as close to the point of cable entry as practical.

#### AM loop antenna assembly

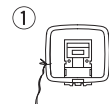

1 Remove the vinyl tie and take out the connection line.

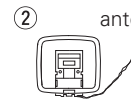

2 Connect to the AM antenna terminals.



3 Bend in the reverse direction.

4 a. With the antenna on top of any stable surface.



Mount

b. With the antenna attached to a wall.

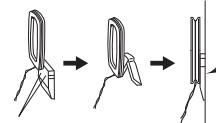

Installation hole Mount on wall, etc.

#### Connection of AM antennas

1. Push the lever.
2. Insert the conductor.
3. Return the lever.



#### NOTE

- Do not connect two FM antennas simultaneously.
- Even if an external AM antenna is used, do not disconnect the AM loop antenna.
- Make sure the AM loop antenna lead terminals do not touch metal parts of the panel.



## Network Audio

### [Wired LAN]

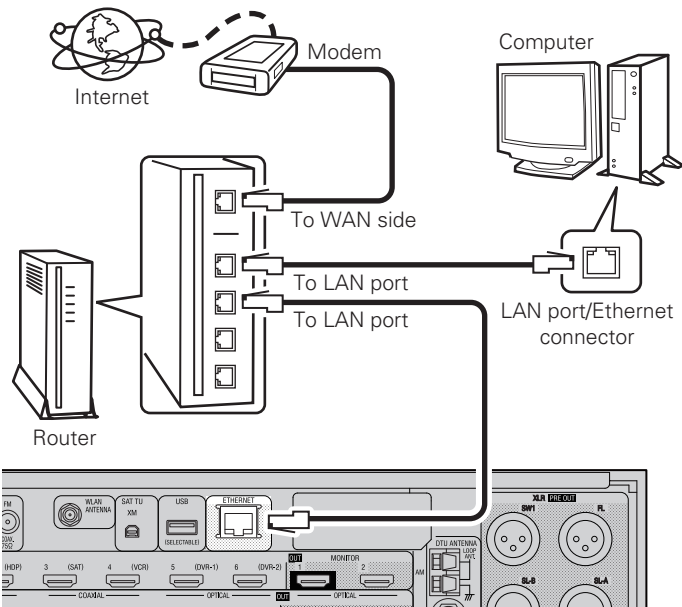

### [Wireless LAN]

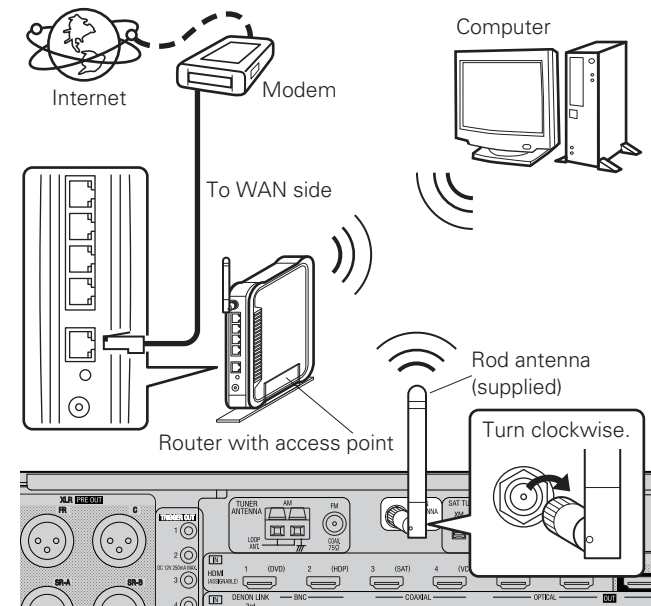

## Required system

### ❑ Broadband Internet connection

A broadband line connection to the Internet is required in order to use the AVP-A1HDCI's Internet radio function and firmware update.

### ❑ Modem

This is a device that is connected to the broadband line to communicate with the Internet. Some are integrated with the router.

### ❑ Router

- When using the AVP-A1HDCI, we recommend you use a router equipped with the following functions:
  - Built-in DHCP (Dynamic Host Configuration Protocol) server  
This function automatically assigns IP addresses on the LAN.
  - Built-in 100BASE-TX switch  
When connecting multiple devices, we recommend a switching hub with a speed of 100 Mbps or greater.
- When using with a wireless LAN, prepare a broadband router with built-in access point.

### ❑ Ethernet cable (CAT-5 or greater recommended)

Use for wired LAN.

- The AVP-A1HDCI does not come with an Ethernet cable.
- Some flat type Ethernet cables are easily affected by noise. We recommend using a normal type cable.
- If the sound is broken in an environment in which there is much power supply noise from electric products or in a noisy network environment, use a shielded type Ethernet cable.

### ❑ Computer

A computer with the following specifications is required to use a media server:

- OS  
Windows® XP Service Pack2, Windows Vista
- Software (Prepare one of the following.)
  - .NET Framework 1.1 and Windows Media Connect (Windows XP)
  - Windows Media Player ver.11
  - DLNA-compatible server software
- Internet browser  
Microsoft Internet Explorer 5.01 or later
- LAN port
- 300 MB or more free disk space

※ Free disk space is required to store music and video files. The following sizes are approximate.

| Format     | Bit rate  | Per minute     | Per hour       |
|------------|-----------|----------------|----------------|
| MP3 / WMA  | 128 kbps  | Approx. 1 MB   | Approx. 60 MB  |
|            | 192 kbps  | Approx. 1.5 MB | Approx. 90 MB  |
|            | 256 kbps  | Approx. 2 MB   | Approx. 120 MB |
| MPEG-4 AAC | 392 kbps  | Approx. 3 MB   | Approx. 180 MB |
|            | 1400 kbps | Approx. 10 MB  | Approx. 600 MB |
| WAV (LPCM) | 1080 kbps | Approx. 7.7 MB | Approx. 464 MB |
| FLAC       |           |                |                |



For connections to the Internet, contact an ISP (Internet Service Provider) or a computer shop.

### NOTE

- A contract with an ISP is required to connect to the Internet. No additional contract is needed if you already have a broadband connection to the Internet.
- The types of routers that can be used depend on the ISP. Contact an ISP or a computer shop for details.
- Depending on the server, video files may be displayed, but they cannot be played on the AVP-A1HDCI.

### ❑ Others

- If you have an Internet provider contract for a line on which network settings are made manually, make the settings at GUI menu "Manual Setup" – "Network Setup" (☞ page 35 ~ 38).
- With the AVP-A1HDCI, it is possible to use the DHCP and Auto IP functions to make the network settings automatically.
- When using a broadband router (DHCP function), the AVP-A1HDCI sets the IP address, etc., automatically. When using the AVP-A1HDCI connected to a network with no DHCP function, make the settings for the IP address, etc., at GUI menu "Manual Setup" – "Network Setup" (☞ page 35 ~ 38).
- The AVP-A1HDCI is not compatible with PPPoE. A PPPoE-compatible router is required if you have a contract for a line of the type with which the PPPoE is set.
- Depending on the ISP with which you have your contract, it may be necessary to make proxy server settings to use the Internet radio function. If you made proxy server settings on the computer to connect to the Internet, make the proxy server settings on the AVP-A1HDCI in the same way.

## Multi Zone

### ZONE2 or ZONE3 Pre-out Connections

- If another power amplifier or pre-main (integrated) amplifier is connected, the ZONE2 or ZONE3 pre-out connectors can be used to play a different program source in ZONE2 or ZONE3 the same time (☞ page 86, 87).
- To the monitor output of ZONE2, various formats of video signals input by the video conversion function are automatically converted and output (☞ page 9).
- To the monitor output of ZONE3, video signals input from the S video terminal or video terminal is output (☞ page 9).
- The ZONE2 (ZONE3) video out is only for ZONE2 (ZONE3).

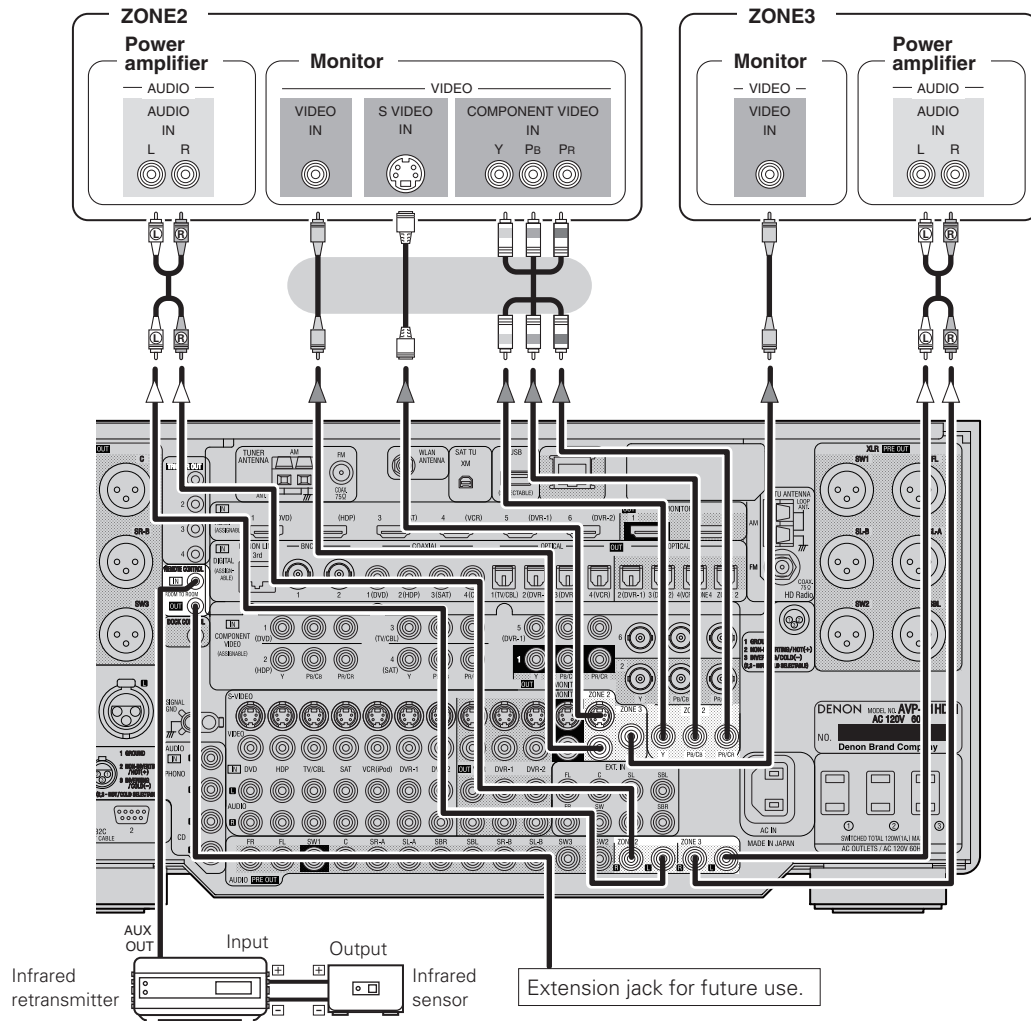

### NOTE

- For the audio output, use high quality pin-plug cords so that no induction humming or noise is produced.
- For instructions on installing and operating separately sold devices, refer to the respective devices' operating instructions.
- To conduct multi-zone playback, see "Multi-Zone Connections and Operations" (☞ page 86, 87).

### ZONE2 or ZONE4 Optical Connections

The AVP-A1HDCI is equipped with Optical output connectors for ZONE2 and ZONE4. If a bit-stream amp is rigged-up, these zones can also be used to enjoy home theater.

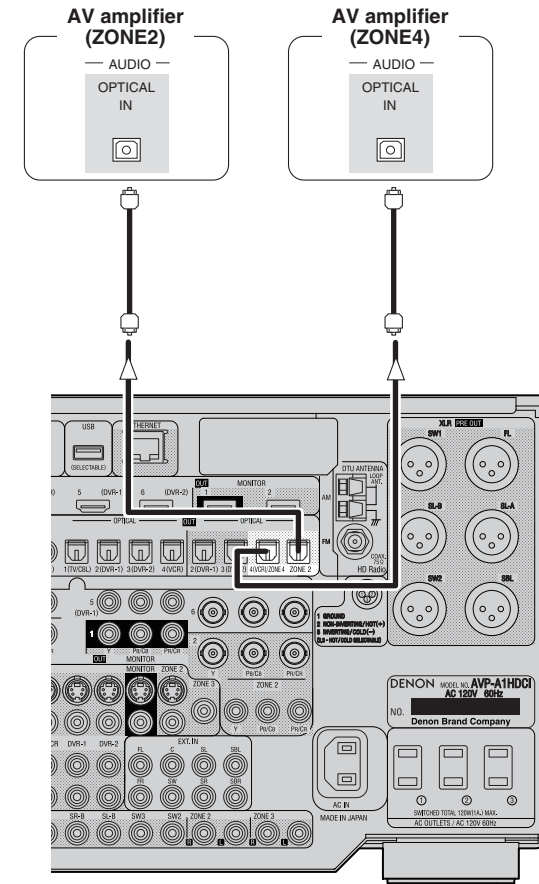

- Connect the monitor for ZONE2 the same as the "ZONE2 or ZONE3 Pre-out Connectors" (☞ See left column).
- If the signal inputted to ZONE2 is analog, change to PCM(2-channel) signal, and output it from ZONE2 optical output connectors.



## External Controller

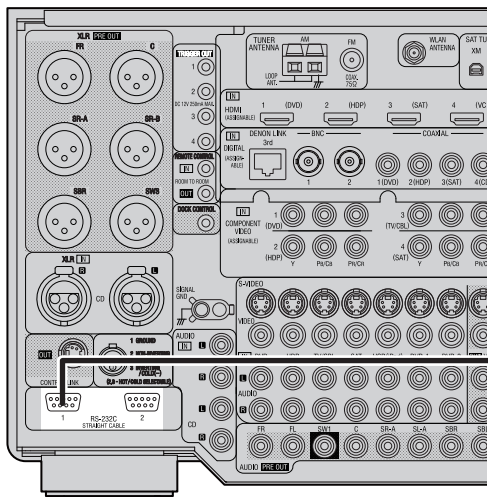

### RS-232C connector

This connector is used for an external controller.

※ If you use an external controller to operate the unit via the RS-232C terminal, you must confirm the following beforehand.

- ① Turn on the AVP-A1HDCI's power.
- ② Turn off the AVP-A1HDCI's power from the external controller.
- ③ AVP-A1HDCI enters the standby status.



- When using in combination with an RF Remote Controller (RC-7000CI, sold separately) and RF Remote Receiver (RC-7001RCI, sold separately) two-way communication with an RF Remote Controller is possible. The AVP-A1HDCI's status information as well as iPod and Internet audio music files can be browsed watching the RF Remote Controller's display. For details, refer to the operating instructions of the respective devices.
- When used in combination with an RF Remote Controller and RF Remote Receiver, make the settings at GUI menu "Manual Setup" – "Option Setup" – "2Way Remote" – "Used" (page 42).
- When using the 2-way remote control unit, connect to the Port 1 RS-232C connector.
- If GUI menu "Manual Setup" – "Option Setup" – "2Way Remote" is set to "Used", you cannot use port 1 of the RS-232C connector for the external controller.

### Trigger output jacks

The power of an external device equipped with a trigger input jack can be turned on and off in association with operations on the AVP-A1HDCI. For details, see GUI menu "Manual Setup" – "Option Setup" – "Trigger Out 1", "Trigger Out 2", "Trigger Out 3" or "Trigger Out 4" (page 42).

- Output level: 250 mA/12 V
- Check the trigger input conditions of the connected device.

## Connecting the Power Cord

Wait until all connections have been completed before connecting the power cord.

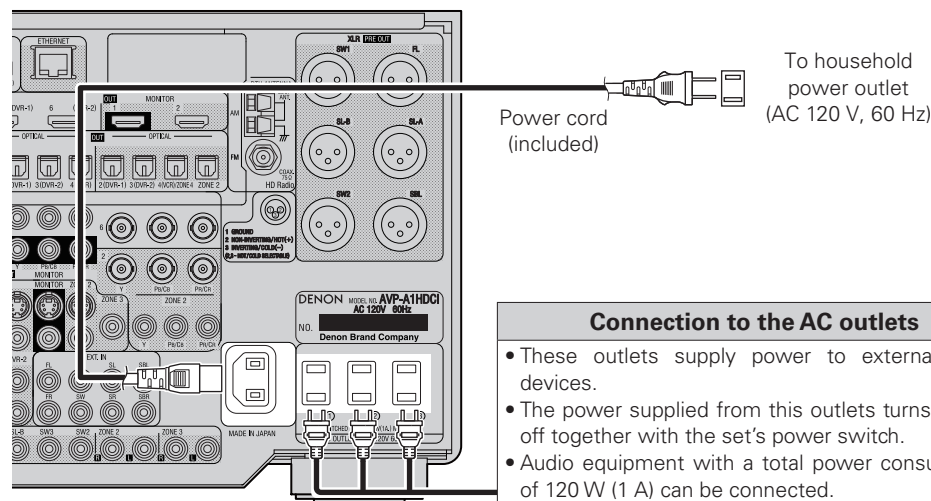

### Connection to the AC outlets

- These outlets supply power to external audio devices.
- The power supplied from this outlets turns on and off together with the set's power switch.
- Audio equipment with a total power consumption of 120 W (1 A) can be connected.

### NOTE

- Insert the AC plugs securely. Incomplete connections could cause noise.
- Only use the AC outlets to plug in audio devices. Do not use them as power supplies for hairdryers or anything other than audio equipment. In addition, do not connect audio devices such as high electricity consumption power amplifiers (e.g. POA-A1HDCI).

## Once Connections are Completed

### Turning the Power On (page 58)

# GUI Menu Operations

With the AVP-A1HDCI, settings and operations for most functions can be performed by operating while looking at the GUI menus displayed on the monitor screen.



The GUI cannot be superimposed when xVCC signals and component 1080p signal, computer's resolution (e.g.VGA) are input.

## Example of the Display of the GUI Mark at a Title

Items for which this mark is indicated at the title can be operated from the GUI.  
We recommend performing such operations from the GUI.

### Auto Setup

Optimize settings for speakers in use.



This is the GUI icon for this setting item or for the menu series to which this item belongs.

## Example of Display of Default Values

In lists of selectable items or adjustable ranges, the item surrounded by a border is the default value.

[Selectable items] **9.1** 7.1 5.1

## Examples of GUI Screen Displays

Some typical examples are described below.

### Example: Browse Menu (Top Menu)

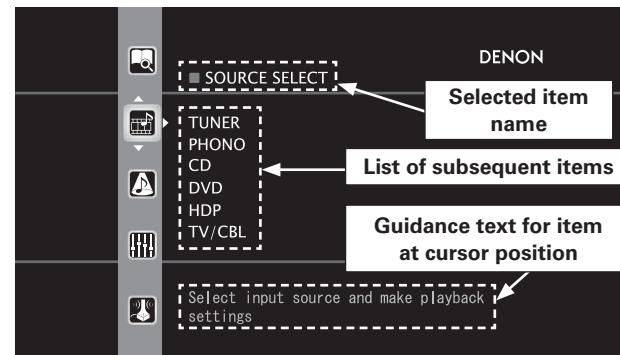

### Example: Menus with Illustrations (Auto Setup)

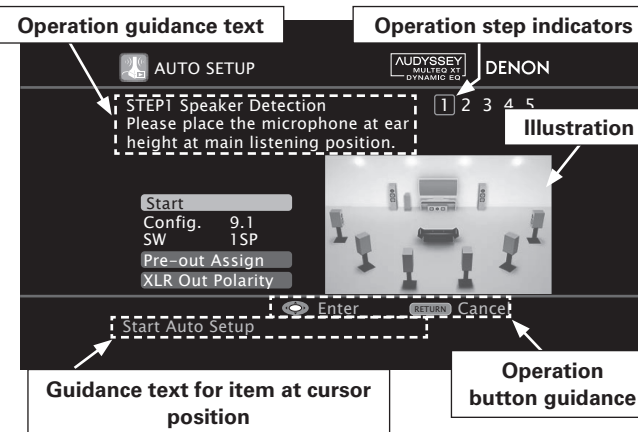

## Cursor Position Display

### Icon

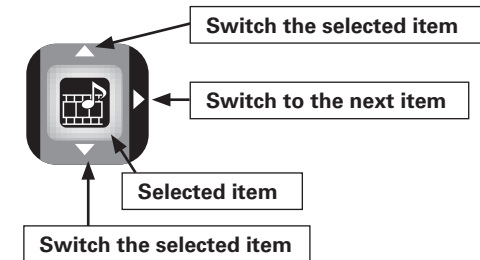

### List

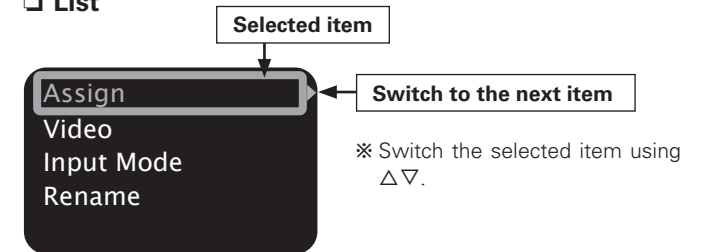

## Operations

The same operation is possible on the main unit or remote control unit.

- 1 Press the MENU button.**  
The GUI menu is displayed.  
※ To operate from the main remote control unit, be sure to set the remote control unit to the AMP mode.
- 2 Press the Δ ∇ ▷ button to select the menu to be set or operated.**  
※ To return to the previous item, press the ◀ or RETURN button.
- 3 Press the ENTER button to enter the setting.**
- 4 Press the MENU button to finish.**

# GUI Menu Map

## Information

(page 56, 57)

- Status
  - MAIN ZONE
  - ZONE2/3/4
- Audio Input Signal
- HDMI Information
- Auto Surround Mode
- Quick Select
- Preset Station

## Parameter

(page 52 ~ 56)

- Audio
  - Surround Parameters
    - Mode
    - Decoder
    - Cinema EQ
    - DRC
    - D.COMP
    - LFE
    - Center Image
    - Panorama
    - Dimension
    - Center Width
    - Delay Time
    - Effect
    - Effect Level
    - Room Size
    - AFDM
    - SB CH Out
    - Input Channel
    - Subwoofer Att.
    - Subwoofer
    - Default
  - Tone
    - Tone Defeat
    - Bass
    - Treble
    - Front
    - Center
    - Surround
    - Surround Back
    - Subwoofer
  - Room EQ
  - Dynamic EQ
  - RESTORER
  - Night Mode
  - Audio Delay
- Picture Adjust
  - Contrast
  - Brightness
  - Chroma Level
  - Hue
  - DNR
  - Enhancer
  - Sharpness

## Source Select (page 45 ~ 49)

- |  |   |   |   |   |   |
|--|---|---|---|---|---|
| <ul style="list-style-type: none"> <li><input type="checkbox"/> TUNER (FM/AM)                     <ul style="list-style-type: none"> <li>• Play</li> <li>• Auto Preset</li> <li>• Preset Skip</li> <li>• Preset Name</li> <li>• Video                             <ul style="list-style-type: none"> <li>• Video Select</li> <li>• i/p Scaler</li> <li>• Resolution</li> </ul> </li> <li>• Input Mode</li> <li>• Rename</li> <li>• Source Level</li> </ul> </li> </ul> | <ul style="list-style-type: none"> <li><input type="checkbox"/> PHONO                     <ul style="list-style-type: none"> <li>• Video                             <ul style="list-style-type: none"> <li>• Video Select</li> <li>• i/p Scaler</li> <li>• Resolution</li> </ul> </li> <li>• Input Mode</li> <li>• Rename</li> <li>• Source Level</li> <li>• Input Att.</li> </ul> </li> </ul> | <ul style="list-style-type: none"> <li><input type="checkbox"/> CD, DVD, HDP, TV/CBL, SAT, VCR, DVR-1, DVR-2, V.AUX                     <ul style="list-style-type: none"> <li>• Play (iPod)</li> <li>• Playback Mode (iPod)                             <ul style="list-style-type: none"> <li>• Video</li> <li>• Video Select</li> <li>• Video Convert (Excluding CD)</li> <li>• i/p Scaler</li> <li>• Resolution</li> <li>• Progressive Mode (Excluding CD)</li> <li>• Aspect (Excluding CD)</li> <li>• Input Mode</li> <li>• Rename</li> <li>• Source Level</li> <li>• Input Att.</li> </ul> </li> <li>• Assign                             <ul style="list-style-type: none"> <li>• HDMI</li> <li>• Digital</li> <li>• Component</li> <li>• Analog (CD only)</li> <li>• iPod dock</li> </ul> </li> </ul> </li> </ul> | <ul style="list-style-type: none"> <li><input type="checkbox"/> NET/USB                     <ul style="list-style-type: none"> <li>• Play</li> <li>• Playback Mode</li> <li>• Still Picture</li> <li>• Video                             <ul style="list-style-type: none"> <li>• Video Select</li> <li>• i/p Scaler</li> <li>• Resolution</li> </ul> </li> <li>• Input Mode</li> <li>• Rename</li> <li>• Source Level</li> </ul> </li> </ul> | <ul style="list-style-type: none"> <li><input type="checkbox"/> XM                     <ul style="list-style-type: none"> <li>• Play</li> <li>• Preset Skip</li> <li>• Antenna Aiming</li> <li>• Video                             <ul style="list-style-type: none"> <li>• Video Select</li> <li>• i/p Scaler</li> <li>• Resolution</li> </ul> </li> <li>• Input Mode</li> <li>• Rename</li> <li>• Source Level</li> </ul> </li> </ul> | <ul style="list-style-type: none"> <li><input type="checkbox"/> HD Radio                     <ul style="list-style-type: none"> <li>• Play</li> <li>• Auto Preset</li> <li>• Preset Skip</li> <li>• Preset Name</li> <li>• Video                             <ul style="list-style-type: none"> <li>• Video Select</li> <li>• i/p Scaler</li> <li>• Resolution</li> </ul> </li> <li>• Input Mode</li> <li>• Rename</li> <li>• Source Level</li> </ul> </li> </ul> |
|--|---|---|---|---|---|

## Surround Mode

(page 50 ~ 52)

- STEREO
- DIRECT
- STANDARD
- DOLBY HEADPHONE  
(When using headphones)
- DOLBY PLIIx, DOLBY PLII or DOLBY PL
- DTS NEO:6
- neural
- HOME THX CINEMA
- 7CH STEREO
- WIDE SCREEN
- SUPER STADIUM
- ROCK ARENA
- JAZZ CLUB
- CLASSIC CONCERT
- MONO
- VIDEO GAME
- MATRIX

## Auto Setup (page 26 ~ 28)

- |   |   |  |
|---|---|--|
| <ul style="list-style-type: none"> <li><input type="checkbox"/> Auto Setup                     <ul style="list-style-type: none"> <li>• STEP1: Speaker Detection</li> <li>• STEP2: Measurement</li> <li>• STEP3: Calculation</li> <li>• STEP4: Check</li> <li>• STEP5: Store</li> </ul> </li> </ul> | <ul style="list-style-type: none"> <li><input type="checkbox"/> Option                     <ul style="list-style-type: none"> <li>• Room EQ</li> <li>• Direct Mode</li> <li>• Mic Select</li> </ul> </li> </ul> | <ul style="list-style-type: none"> <li><input type="checkbox"/> Parameter Check                     <ul style="list-style-type: none"> <li>• Speaker Configuration Check</li> <li>• Distance Check</li> <li>• Channel Level Check</li> <li>• Crossover Check</li> <li>• EQ Check</li> <li>• Restore</li> </ul> </li> </ul> |
|---|---|--|

## Manual Setup (page 29 ~ 44)

- |   |  |  |
|---|--|--|
| <ul style="list-style-type: none"> <li><input type="checkbox"/> Speaker Setup (page 29 ~ 31)                     <ul style="list-style-type: none"> <li>• Speaker Configuration</li> <li>• Subwoofer Setup</li> <li>• Distance</li> <li>• Channel Level</li> <li>• Crossover Frequency</li> <li>• THX Audio Setup</li> <li>• Surround Speaker</li> </ul> </li> <li><input type="checkbox"/> HDMI Setup (page 32)                     <ul style="list-style-type: none"> <li>• Color Space</li> <li>• RGB Range</li> <li>• Auto Lip Sync</li> <li>• Audio</li> <li>• Monitor Out</li> <li>• HDMI Control</li> </ul> </li> <li><input type="checkbox"/> Audio Setup (page 33, 34)                     <ul style="list-style-type: none"> <li>• EXT. IN Setup                             <ul style="list-style-type: none"> <li>• Mode</li> <li>• Surround Back Input</li> <li>• Surround Speaker</li> <li>• Subwoofer Level</li> <li>• Input Att.</li> </ul> </li> <li>• 2ch Direct/Stereo</li> <li>• Downmix Option</li> <li>• Auto Surround Mode</li> <li>• Manual EQ</li> </ul> </li> </ul> | <ul style="list-style-type: none"> <li><input type="checkbox"/> Network Setup (page 35 ~ 38)                     <ul style="list-style-type: none"> <li>• Network Setup</li> <li>• Other                             <ul style="list-style-type: none"> <li>• Power Saving</li> <li>• Character</li> <li>• PC Language</li> <li>• Rhapsody Account</li> </ul> </li> <li>• Network Information</li> </ul> </li> <li><input type="checkbox"/> Zone Setup (page 39)                     <ul style="list-style-type: none"> <li>• ZONE2, ZONE3                             <ul style="list-style-type: none"> <li>• Bass</li> <li>• Treble</li> <li>• HPF</li> <li>• Lch Level</li> <li>• Rch Level</li> <li>• Channel</li> <li>• Volume Level</li> <li>• Volume Limit</li> <li>• Power On Level</li> <li>• Mute Level</li> <li>• Video Convert (ZONE2 only)</li> </ul> </li> <li>• OSD</li> </ul> </li> </ul> | <ul style="list-style-type: none"> <li><input type="checkbox"/> Option Setup (page 40 ~ 44)                     <ul style="list-style-type: none"> <li>• Pre-out Assign</li> <li>• XLR Out Polarity</li> <li>• POA Setting</li> <li>• Volume Control                             <ul style="list-style-type: none"> <li>• Volume Limit</li> <li>• Power On Level</li> <li>• Mute Level</li> </ul> </li> <li>• Source Delete</li> <li>• GUI                             <ul style="list-style-type: none"> <li>• Screensaver</li> <li>• Wall Paper</li> <li>• Format</li> <li>• Text</li> <li>• Master Volume</li> <li>• NET/USB / iPod / Tuner</li> </ul> </li> <li>• Quick Select Name</li> <li>• Trigger Out 1</li> <li>• Trigger Out 2</li> <li>• Trigger Out 3</li> <li>• Trigger Out 4</li> <li>• Transducer Setup</li> <li>• Digital Out</li> <li>• Remote ID</li> <li>• 2Way Remote</li> <li>• Dimmer</li> <li>• Setup Lock</li> <li>• Maintenance Mode</li> <li>• Firmware Update</li> <li>• Add New Feature</li> </ul> </li> <li><input type="checkbox"/> Language (page 44)</li> </ul> |
|---|--|--|

When "Screensaver" is set to "ON", the screensaver is activated if no operation is performed for about 3 minutes.

# Auto Setup



- Audyssey MultEQ® XT automatically measures the acoustical problems in the listening environment to create the best audio experience for your home theater.
- It optimizes a large listening area where one or more listeners are seated.

Measurements are performed by placing the calibrated microphone (DM-A505Z) successively at multiple positions throughout the listening area as shown in **Example ①**. For best results, it is strongly recommended to measure 6 or more positions so that the measurements have the proper spatial weighting.

Even if the listening environment is small as shown in **Example ②**, measuring at multiple points throughout the listening environment results in more effective correction.

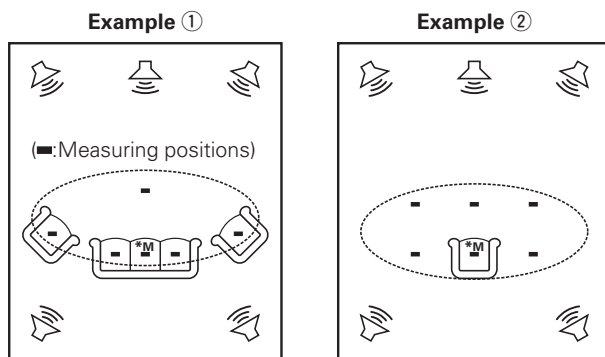

## About the main listening position (\*M)

The main listening position refers to the most central position where one would normally sit within the listening environment.

MultEQ XT uses the measurements from this position to calculate speaker distance, level, polarity, and the optimum crossover value for the subwoofer.



To make manual adjustments to the settings, see pages 29 ~ 31.

## Preparations

### 1 Connect the included calibrated setup microphone to the SETUP MIC jack on the main unit.

The "Auto Setup" screen appears automatically.

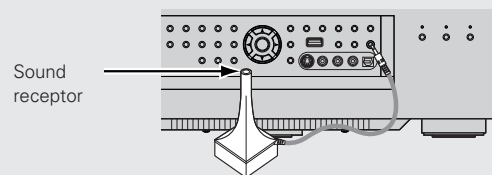

### 2 Place the microphone at ear height on a tripod or stand with the microphone pointing directly up towards the ceiling.

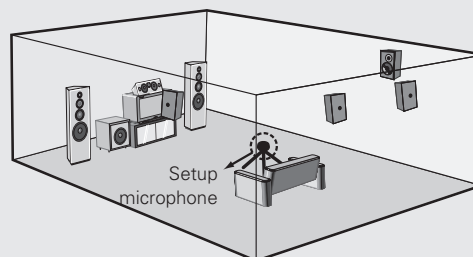

※ It is not recommended to hold it in your hand. Be sure that the path from microphone to the speakers is not blocked by objects. Avoid placing the microphone close to a seat back or wall as sound reflections may give inaccurate results.



When using a subwoofer, make the following settings before starting the auto setup procedure:

- Defeat the volume and crossover controls if possible
- If this is not possible then set
  - Volume: "12 o'clock" position
  - Crossover frequency: "Maximum/Highest Frequency"
  - Low pass filter: "Off"
  - Standby mode: "Off"

## NOTE

- Do not disconnect the setup microphone until the auto setup procedure is completed.
- When using headphones, unplug the headphones before starting the auto setup procedure.

## Auto Setup

Optimize settings for speakers in use.



### Menu tree

#### Auto Setup

- 1 Auto Setup
- 2 Option
- 3 Parameter Check

### 1 Auto Setup

The settings are performed automatically.



#### [Auto setup flow]

#### STEP1: Speaker Detection



#### STEP2: Measurement (2 to 8 positions)



#### STEP3: Calculation



#### STEP4: Check



#### STEP5: Store

## Start

Start Auto Setup.

The Audyssey MultEQ XT Auto Setup process automatically calculates the size, level, distance, bass management crossover frequency, and optimal settings for each speaker and subwoofer. Audyssey MultEQ XT corrects acoustical distortions within the listening area.

Before starting, connect and position all your speakers.

Once started, MultEQ XT will play a series of test tones through each speaker.



If an error message appears during the measurements, check “Error Messages” (page 28), take the advised action, then start the measurements again.

## Configuration

The speaker system to be measured can be selected ahead of time here.

|                    |        |        |        |
|--------------------|--------|--------|--------|
| [Selectable items] | 9.1 *1 | 7.1 *1 | 5.1 *1 |
|                    | 9.2 *2 | 7.2 *2 | 5.2 *2 |
|                    | 9.3 *3 | 7.3 *3 | 5.3 *3 |

\*1: This can be set when “Subwoofer” is set to “1SP”.

\*2: This can be set when “Subwoofer” is set to “2SP L/R” or “2SP MIX”.

\*3: This can be set when “Subwoofer” is set to “3SP L/R/LFE” or “3SP MIX”.



Setting the correct speaker configuration can reduce the time required to measure during the auto setup procedure as the system will not have to look for speakers that are not connected.

## Subwoofer

The configuration of the measuring subwoofer can be selected beforehand.

|                    |             |         |         |
|--------------------|-------------|---------|---------|
| [Selectable items] | 1SP         | 2SP L/R | 2SP MIX |
|                    | 3SP L/R/LFE | 3SP MIX |         |

## Pre-out Assign

Change the pre-out assignment.

[Selectable items] **Normal** **Free Assign**

## XLR Out Polarity

Set to switch the XLR pre-out terminal polarity.

[Selectable items] **XLR** **XLR (INV)**



Set each channel.

## STEP1 : Speaker Detection

The speaker connection and polarity are detected at the first measurement position. The following attributes are also determined at this time: “Speaker Size”, “Speaker Distance”, “Channel Level”, “Crossover Frequency”.

Once the measurements are completed, the results are displayed.

### NOTE

- Loud test tone may be played during Audyssey MultEQ XT Automatic Speaker Setup. This is part of normal operation. If there is background noise in room, these test tones will increase in volume.
- Do not stand between the speakers and setup microphone or allow obstacles in the path while the measurements are being made. This will cause inaccurate readings.
- Quiet the listening environment before beginning measurements and refrain from talking. Turn off air conditioning units or other devices that emit noise if at all possible as measurements may be affected by these sounds.
- Operating the **MASTER VOLUME** knob on the main unit or the **VOL +/-** buttons on the remote control unit during the measurements will cancel the measurements.
- Do not change the speaker connections or subwoofer volume after “STEP1”.

## STEP2: Measurement

After completing a measurement position, move the microphone to the next position.



Measure at least 6 positions (main listening position and at least 5 other surrounding positions). For best results it is recommend measuring **6 or more positions** (with a maximum of 8 positions).

## STEP3: Calculation

When “Calculate” is selected at “STEP2”, the measurements taken are analyzed automatically to determine how the speaker system interacts with the room.



The time required for this analysis depends on the number of speakers connected. The higher the number of speakers, the longer the time required for analysis.

## STEP4: Check

Once the auto setup procedure is complete, a measuring result check screen appears.

Select any item whose results you want to check to review the results.



Values that are different from the actual distance may be set for speakers with built-in filters (subwoofers, etc.). This is because filters add electrical delay to the signal that should be compensated.

## STEP5: Store

The auto setup measurement results are stored in the AVP-A1HDCI.

### NOTE

Do not turn the power off while the settings are being stored.

## Error Messages

If the auto setup procedure could not be completed due to speaker installation, the measuring environment, etc., an error message is displayed. If this happens, check the relevant items, be sure to take the necessary measures, then perform the auto setup procedure over again.

| Error messages (examples)                            | Cause   | Measures  |
|--|---|---|
| <b>No microphone or speaker</b>                      | <ul style="list-style-type: none"> <li>Included setup microphone is not connected.</li> <li>Not all speakers could be detected.</li> <li>The front L speaker was not properly detected.</li> </ul>  | <ul style="list-style-type: none"> <li>Connect the included setup microphone to the <b>SETUP MIC</b> jack on the main unit.</li> <li>Check the speaker connections.</li> </ul>  |
| <b>Ambient noise is too high or Level is too low</b> | <ul style="list-style-type: none"> <li>Too much noise in the room for accurate measurements to be made.</li> <li>Speaker or subwoofer sound is too low for accurate measurements to be made.</li> </ul>   | <ul style="list-style-type: none"> <li>Either turn off any device generating noise or move it away.</li> <li>Try again when the surroundings are quieter.</li> <li>Check the speaker installation and the direction in which the speakers are facing.</li> <li>Adjust the subwoofer's volume.</li> </ul>  |
| <b>None</b>  | <ul style="list-style-type: none"> <li>Displayed speaker could not be detected.                             <ul style="list-style-type: none"> <li>The front R speaker was not properly detected.</li> <li>Only one channel of the surround (A) and surround (B) speakers was detected.</li> <li>Sound was output from the R channel when only one surround back speaker was connected.</li> <li>The surround back or the surround (B) speaker was detected, but the surround (A) speaker was not detected.</li> <li>When the subwoofer configuration is set at "2SP L/R", "2SP MIX", "3SP L/R/LFE" or "3SP MIX", the subwoofer could not be detected.</li> </ul> </li> </ul> | <ul style="list-style-type: none"> <li>Check the connections of the displayed speaker.</li> </ul>   |
| <b>Phase</b>   | <ul style="list-style-type: none"> <li>Displayed speaker connected with the polarities reversed.</li> <li>If the XLR pre-out terminal is used, the polarity is reversed.</li> </ul>   | <ul style="list-style-type: none"> <li>Check the polarities of the displayed speaker.</li> <li>Check the polarity setting for the XLR output of the displayed pre-set channel.</li> <li>For some speakers, this error message may be displayed even if the speaker is properly connected. If you are sure that the wiring is correct, select "Skip".</li> </ul> |

- Sometimes due to the electrical complexities of subwoofers and the interaction with the room, THX recommends setting the level and the distance of the subwoofer manually.
- Sometimes due to interaction with the room, you may notice irregular results when setting the level and/or distance of the main speakers. If this happens, THX recommends setting them manually.
- Please note that any THX main speakers should be set to Small (80 Hz). If you set up your speakers using Auto Setup, please make sure manually that any THX speakers are set to Small with 80 Hz crossover.

 Select "Retry" to make the measurements again.

**NOTE** Be sure to turn the power off before checking the speaker connections.

## 2 Option

Select settings for room EQ, mic, etc.



### Room EQ

Select room EQ setting method.

[Selectable items] **All** **Assign**

### Direct Mode

Select room EQ use for DIRECT or PURE DIRECT mode.

[Selectable items] **ON** **OFF**

### Mic Select

Select the microphone type if not using supplied mic. The microphone connected to V.AUX Lch is used.

[Selectable items] **Mic** **V.AUX L**



Only a professionally certified installer should ever connect a professionally-calibrated microphone to the V.AUX L input on the front panel.

## 3 Parameter Check

Check auto setup measurement results. This is displayed after the auto setup procedure is completed.



[Selectable items]

**Spkr Config Check** **Distance Check** **Ch. Level Check**

**Crossover Check** **EQ Check** **Restore**



The auto setup results can be reset to what was originally calculated by MultEQ XT when "Restore" is selected.



# Manual Setup

GUI



Make detailed settings for various parameters

## Speaker Setup

Use this procedure to set the speakers manually or if you wish to change the settings made with the auto setup procedure.

GUI



### Menu tree

#### Manual Setup

#### Speaker Setup

- 1 Speaker Configuration
- 2 Subwoofer Setup
- 3 Distance
- 4 Channel Level
- 5 Crossover Frequency
- 6 THX Audio Setup
- 7 Surround Speaker

## 1 Speaker Configuration

Select speaker configuration and size.  
(bass reproduction capability)

### Front

Select front speaker size.

[Selectable items] **Large** **Small**

### Center

Select center speaker use and size.

[Selectable items] **Large** **Small** **None**

### Subwoofer

Select subwoofer use.

[Selectable items] **Yes** **No**

### Surround A

Select surround speakers A use and size.

[Selectable items] **Large** **Small** **None**

### Surround B

Select surround speakers B use and size.

[Selectable items] **Large** **Small** **None**

### Surround Back

Select surround back speaker use and size.

[Selectable items] **Large** **Small** **None**  
**2spkrs** **1spkr**

**Large** : Select this for a large speaker with strong bass reproduction.

**Small** : Select this for a smaller speaker with weaker bass reproduction.



- Select "Large" or "Small" not according to the physical size of the speaker but according to the low frequency reproduction capabilities based on the frequency set at "Crossover Frequency" (page 30, 31).
- When "Front" is set to "Small", "Subwoofer" is automatically set to "Yes".
- If "Subwoofer" is set to "No", "Front" is automatically set to "Large".
- If "Surround A" is set to "None", "Surround B" and "Surround Back" are automatically set to "None".
- When using just one surround back speaker, connect it to the left channel (SBL).
- To take full advantage of the performance of the Home THX certified speaker systems, set the front, center and surround speaker size parameters to "Small" and the subwoofer to "Yes".

## 2 Subwoofer Setup

Select subwoofer output configuration and bass signal for playback.

### Configuration

Select number of subwoofers and configuration.

[Selectable items]

**1SP** **2SP L/R** **2SP MIX** **3SP L/R/LFE** **3SP MIX**

| Subwoofer Configuration | Subwoofer Connector |     |
|-------------------------|---------------------|-----|
| 1SP                     |                     | SW1 |
| 2SP L/R                 | L                   | SW1 |
|                         | R                   | SW2 |
| 2SP MIX                 | 1                   | SW1 |
|                         | 2                   | SW2 |
| 3SP L/R/LFE             | L                   | SW1 |
|                         | R                   | SW2 |
|                         | LFE                 | SW3 |
| 3SP MIX                 | 1                   | SW1 |
|                         | 2                   | SW2 |
|                         | 3                   | SW3 |



When "2SP MIX" or "3SP MIX" is selected, "Subwoofer 1", "Subwoofer 2" and "Subwoofer 3" are each displayed.

### Mode

Select bass signal for playing with the subwoofer.

[Selectable items] **LFE-THX-** **LFE+Main**



- THX recommends LFE-THX- mode so that bass interference is less likely to occur in the room.
- This can be set when the GUI menu "Speaker Configuration" – "Subwoofer" is set to "Yes".
- Play music or a movie source and select the mode offering the strongest bass.
- Select "LFE+Main" if you want the bass signals to always be produced from the subwoofer.



### 3 Distance

Set distance from listening position to speakers.  
Before making the settings, measure the distance from the listening position to the different speakers.

#### Feet / Meters

Select unit for distance.

#### Step

Select step. (smallest distance)

#### [Selectable items]

**1ft** **0.1ft** : Can be selected when "Feet" is set.

**0.1m** **0.01m** : Can be selected when "Meters" is set.

#### Default

Resets the settings to the default values.

#### Distance measurement

Select the speaker you want to set, then set the distance.  
Set the value closest to the measured distance.

#### [Variable range]

**0.0ft ~ 60.0ft** : Display when "Feet" is set.

**0.00m ~ 18.00m** : Display when "Meters" is set.



Two surround back speakers are required to use the THX Ultra2 Cinema, THX Music mode and THX Games mode.

Set the surround back speakers so that the distance to the listening position is the same for both the left and right speakers.

It is also recommended that the deviations of the distance from the listening position to L and R channel speakers (front left (FL) and front right (FR), surround left (SL) and surround right (SR), surround back left (SBL) and surround back right (SBR) is less than 2 ft (60 cm).

#### NOTE

Set the distance between the listening position and the various speakers to no more than 20 ft (6.00 meters).

### 4 Channel Level

Adjust channel levels to obtain equal volume from all speakers.

#### Mode

Select test tone playback method.

[Selectable items] **Auto** **Manual**

#### Surround

Select surround speaker from which test tone is output.

[Selectable items] **A** **B** **A+B**

#### Start

Output test tone.

[Variable range] **OFF** \* **-12dB** ~ **0dB** ~ **+12dB**

\*: "OFF" can be set by pressing ◀ when the subwoofer's volume is set to -12 dB.

#### Default

Resets the settings to the default values.



#### Operating from the main remote control unit

Adjusting with the main remote control unit using the test tones is only possible in the "Auto" mode and only effective in the STANDARD (Dolby/DTS Surround) and HOME THX CINEMA modes. The adjusted levels for the different modes are automatically stored in the memory.

#### [Adjusting using test tones]

- ① Press the **TEST** button.  
Test tones are output from the various speakers.
- ② Use the ◀ ▶ button to adjust so that the volume is equal for all speakers.
- ③ When the adjustments are completed, press the **TEST** button again.



- The level of each channel should be adjusted to 75 dB (Cweighted, slow meter mode) on a sound level meter at the listening position. If a sound level meter is not available adjust the channels by ear so the sound levels are the same. Because adjusting the subwoofer level test tone by ear is difficult, use a well known music selection and adjust for natural balance.
- When the GUI menu "Speaker Configuration" – "Surround Back" setting (page 29) is set to "1spkr", the surround back speaker display is set to "Surround Back".
- Speakers set to "None" in the "Speaker Configuration" settings are not displayed.
- "Surround" can be set when GUI menu "Speaker Configuration" – "Surround B" is set to "Large" or "Small" (page 29).
- When using surround speakers, be sure to adjust the volume of the different speakers.
- When "Channel Level" is adjusted, the adjusted values are set for all the surround modes. To adjust the channel level separately for the different surround modes, use the operation see page 75.

### 5 Crossover Frequency

Select crossover frequency from which subwoofer handles low range signal.

#### [Selectable items]

**FIXED-THX-** :

Setup when using a THX-certified speaker.

**40Hz** **60Hz** **80Hz** **90Hz** **100Hz** **110Hz** **120Hz** **150Hz**  
**200Hz** **250Hz** :

Only the portion of the bass sound of the various speakers output from the subwoofer that has a frequency below the frequency set here is output.

Set this according to the low frequency reproduction capabilities of the speakers you are using.

**Advanced** :

Specify crossover frequency for each speaker.



- Please set all THX Certified speakers, set the “Speaker Configuration” for all speakers to “Small”. We recommend using with the crossover frequency set to “FIXED-THX-”, but depending on the speaker, setting it to a different frequency may improve frequency response near the crossover frequency.
- The “Crossover Frequency” can be set when there are speakers that have been set to “Small” at GUI menu “Speaker Configuration” or when “Subwoofer” is set to “Yes” (page 29).
- At the “Advanced” settings, if the “Subwoofer Setup” (page 29) setting is set to “LFE-THX-”, GUI menu speakers for which “Speaker Configuration” is set to “Small” can be set. If set to “LFE+Main”, the setting can be made regardless of the speaker size.
- For speakers set to “Small”, sound below the crossover frequency is cut from the sound output. The cut bass sound is output from the subwoofer or front speakers.

## 6 THX Audio Setup

Set the speaker to play the optimal THX surround mode.

### THX Ultra2 Subwoofer

Set when using a subwoofer compatible with THX Ultra2 standards or a subwoofer that can be properly played at low range.

[Selectable items] **Yes** **No**



Make these settings when “Yes” is selected for the subwoofer in the “Speaker Configuration” settings. This option is not available when “No” is selected (page 29).

### BGC (Boundary Gain Compensation)

If bass sound feels big compensate by lowering volume.

[Selectable items] **ON** **OFF**



- If the bass sound seems too strong:  
Set “BGC” to “ON”. This activates a filter that gently reduces very deep bass below 55 Hz to provide the flattest overall deep bass response. Select “ON” or “OFF” according to how strong you prefer the deep bass response to be.
- This can be set when the “THX Ultra2 Subwoofer” setting is set to “Yes”.

### SB Speaker Position

Set the distance between the left and right surround back speakers.

[Selectable items] **Under 1ft** **1ft – 4ft** **Over 4ft**



- When two surround back speakers have been set in “Speaker Configuration” (page 29), set the distance of the speakers. This option is not available when “1spkr” is selected.
- This setting is necessary to achieve the optimum effect in the THX Surround EX, THX Ultra2 Cinema, THX Music mode and THX Games mode.

## 7 Surround Speaker

Select surround speakers to use for each surround mode.

### THX/DOLBY/DTS Cinema

[Selectable items] **A** **B** **A+B**

### THX/DOLBY/DTS Music

[Selectable items] **A** **B** **A+B**

### THX/DOLBY Game

[Selectable items] **A** **B** **A+B**

### WIDE SCREEN

[Selectable items] **A** **B** **A+B**

### 7CH STEREO

[Selectable items] **A** **B** **A+B**

### DSP SIMULATION

[Selectable items] **A** **B** **A+B**

### MULTI CH MODE

[Selectable items] **A** **B** **A+B**



### Operating from the main remote control unit

Press the **SPKR** button.

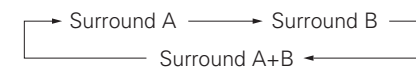

- This can be set when GUI menu “Speaker Configuration” – “Surround A” and “Surround B” are used (page 29).
- Make the surround speaker settings when the input mode is set to “EXT. IN” at GUI menu “Manual Setup” – “Audio Setup” – “EXT. IN Setup” (page 33).

### About Speaker Type Setting when Using Both Surround speakers A and B

If “Small” is set for either surround speakers A or B, the output is the same as when “Small” is set for both A and B.

## HDMI Setup

Make settings for HDMI video/audio output.

GUI



### Menu tree

#### Manual Setup

#### HDMI Setup

1 Color Space

2 RGB Range

3 Auto Lip Sync

4 Audio

5 Monitor Out

6 HDMI Control

## 1 Color Space

Make settings for output color space.

[Selectable items] **YCbCr** RGB



When connected to a monitor with a DVI-D connector (HDCP compatible) using an HDMI/DVI converter cable, the signals are output in RGB format, regardless of this setting.

## 2 RGB Range

Make settings for RGB output range.

[Selectable items] **Normal** Enhanced



When "YCbCr" is selected under "Color Space", "RGB Range" will have no effect.

## 3 Auto Lip Sync

Automatic compensation for timing shift in audio and video output.

[Selectable items] **ON** OFF

## 4 Audio

Select HDMI audio output device.

[Selectable items] **Amp** TV



GUI menu "HDMI Control"- "Control" is "ON", the "Amp" and "TV" will switch with the operation of any television not related to this setting.

## 5 Monitor Out

Make settings for HDMI monitor output.

[Selectable items] **Auto (Dual)** Monitor 1 Monitor 2



### Operating from the main remote control unit

Press the **M.SEL** button.



- When "Monitor Out" is set to "Auto (Dual)", connections with the MONITOR 1 or MONITOR 2 connectors are recognized automatically.
- If both the MONITOR 1 and 2 connectors are connected and "Resolution" is set to "Auto" (page 47), the signals are output with a resolution compatible with both monitors.
- If "Resolution" is set to something other than "Auto", check the resolutions with which your monitor is compatible at GUI menu "Information" – "HDMI Information" – "Monitor 1" and "Monitor 2" and set accordingly (page 57).

### NOTE

Depending on the monitor you have connected, the display may not be correct when you set to "Auto (Dual)". In such a case, set to either "Monitor 1" or "Monitor 2".

## 6 HDMI Control

Make settings for HDMI control function.

### Control

Set HDMI control function to ON/OFF.

[Selectable items] **ON** OFF

### Control Monitor

Select the interlocking monitor through the HDMI controls.

[Selectable items] **Monitor1** Monitor2



This can be set when "Control" is set to "ON".

### Power Off Control

Interlock with the power off function through the HDMI controls.

[Selectable items] **ON** OFF



- This can be set when "Control" is set to "ON".
- Please consult the operating instructions for each connected device to check the settings.

### NOTE

- When the "Control" setting has been changed, always turn off the power to the connecting devices afterwards and then turn back on.
- The HDMI control function does not work when the power to the equipment is off.
- For details, see "HDMI Control Function" (page 74).

# Audio Setup

Make settings for audio playback.

**GUI**

● Menu tree ●

- Manual Setup
  - Audio Setup
    - 1 EXT.IN Setup
    - 2 2ch Direct/Stereo
    - 3 Downmix Option
    - 4 Auto Surround Mode
    - 5 Manual EQ

## 1 EXT. IN Setup

Setup playback method for analog signals inputted from external input connectors (EXT. IN).

### Mode

Select playback mode.

[Selectable items] **DSP** Analog

### Surround Back Input

Select surround back channel input in combination with the connected player.

[Selectable items] **Not Used** SBL/SBR SB(SBL)

 This can be set when "Mode" is set to "DSP".

### Surround Speaker

Select the surround speakers to use.

[Selectable items] **A** B A+B

 This can be set when "Mode" is set to "Analog".  
 • This can be set when GUI menu "Speaker Setup" – "Speaker Configuration" – "Surround A" and "Surround B" are used (page 29).

### Subwoofer Level

Set the subwoofer level for playback.  
 Select according to the player in use.

[Selectable items] **0dB** +5dB +10dB +15dB

 We recommend setting to "+15 dB".

### Input Att.

Setup when input level is too large and playback volume is distorted.

[Selectable items] **OFF** -6dB

 This can be set when "Mode" is set to "DSP".

## 2 2ch Direct/Stereo

Make speaker settings for 2-channel mode playback.

### Setting

To change the settings, select "Custom".

[Selectable items] **Basic**\* Custom

\*: Use the same settings as in "Speaker Setup".

### Front

Select front speaker size.

[Selectable items] **Large** Small

### Subwoofer

Select subwoofer use.

[Selectable items] **Yes** No

### Subwoofer Mode

Select low range signal to be reproduced by subwoofer.

[Selectable items] **LFE-THX-** LFE+Main

### Crossover

Select crossover frequency from which subwoofer handles low range signal.

[Selectable items] **THX** 40Hz 60Hz 80Hz 90Hz 100Hz 110Hz 120Hz 150Hz 200Hz 250Hz

### Distance FL

Set distance from listening position to front left speaker.

[Variable range] **0.0ft ~ 60.0ft**

### Distance FR

Set distance from listening position to front right speaker.

[Variable range] **0.0ft ~ 60.0ft**

### 3 Downmix Option

Set dynamic range for downmix playback of Dolby Digital sources.

[Selectable items]  ON  OFF



- Set this to "ON" if the sound from the front speakers seems distorted.
- When not using the center speaker or surround speakers, the playback sound is down-mixed and output from the front speakers.

### 4 Auto Surround Mode

Make setting for memorizing surround mode setting for each input signal type.

[Selectable items]  ON  OFF



- The auto surround mode function lets you store in the memory the surround mode last used for playing the four types of input signals listed below.
  - ① Analog and PCM 2-channel signals
  - ② Dolby Digital and DTS 2-channel signals
  - ③ Dolby Digital and DTS multi-channel signals
  - ④ Multi-channel signals other than Dolby Digital and DTS (PCM, DSD, etc.)
- When playing in the PURE DIRECT mode, the surround mode does not change even if the input signal is changed.

### 5 Manual EQ

Adjust tonal quality for each speaker using graphic equalizer.

#### Adjust CH

Select speaker adjustment method.

[Selectable items]  Each  L/R  All

Select the speaker and frequency band and adjust the level.

[Selectable items]

63Hz  125Hz  250Hz  500Hz  1kHz  2kHz  4kHz  8kHz  
 16kHz

[Variable range]

-20dB ~  0dB ~  +6dB

#### Curve Copy

Copy the Room EQ's "Audyssey Flat" correction curve.

[Selectable items]  Yes  No



"Curve Copy" is displayed after the auto setup procedure has been performed.

#### Default

Resets the settings to the default values.

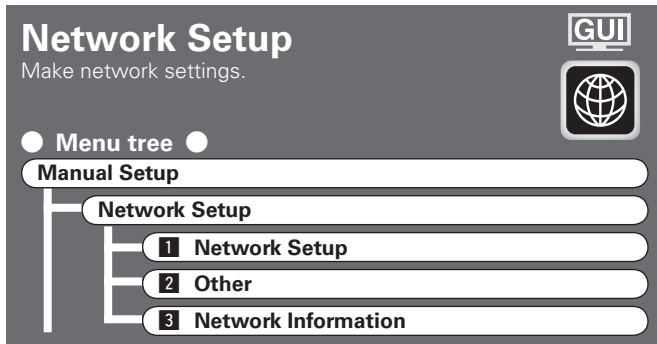

- If you are using a broadband router (DHCP function), there is no need to make the settings at “Setting the IP Address” and “Setting the Proxy”, since the DHCP function is set to “ON” in the AVP-A1HDCI’s default settings.
- If the AVP-A1HDCI is being used connected to a network without the DHCP function, the network settings must be made. In this case, some knowledge of networks is required. For details, consult a network administrator.
- If you cannot connect to the Internet, recheck the connections and settings (page 21).
- If you do not understand about Internet connection, contact your ISP (Internet Service Provider) or the store from which you purchased your computer.



- **DHCP (Dynamic Host Configuration Protocol)** :  
These are systems by which the IP address and other network settings are automatically set for the AVP-A1HDCI, computer, broadband router and network devices.
- **DNS (Domain Name System)** :  
This is a system for converting the domain names used when browsing Internet sites (for example, “www.denon.jp”) into the IP addresses actually used for communications (for example, “202.221.192.106”).

## 1 Network Setup

Make settings for wired or wireless LAN.

### Wired LAN settings

Use this procedure to configure the Wired LAN settings.

#### 1 Connect the LAN cable (page 21).

#### 2 Turn on the AVP-A1HDCI (page 58).

AVP-A1HDCI performs automatic network setup due to the DHCP function.

When connecting to a network that has no DHCP function, perform the setting in step 3.

#### 3 Set the IP address at the GUI menu “Manual Setup” – “Network Setup”.

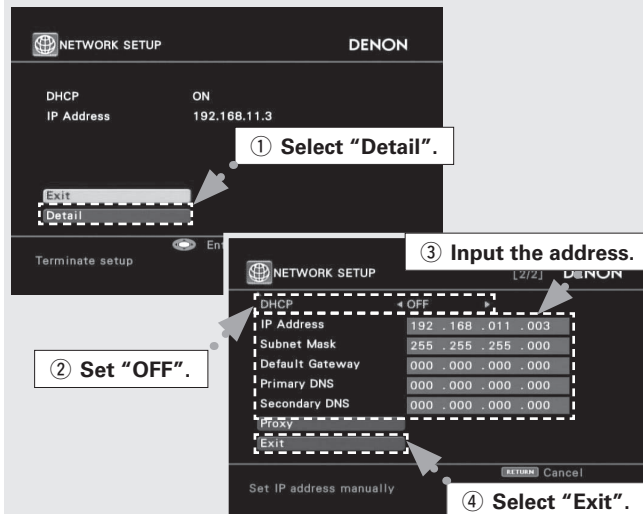

- 1 Select “Detail” and press the **ENTER** button.
- 2 Use the < > button to set “DHCP” to “OFF”, then press the ▾ button.  
The DHCP function is disabled.

- 3 Use the Δ ▽ ▷ button to input the address and press the **ENTER** button.

#### IP Address :

Set the IP address within the ranges shown below. The Network Audio function cannot be used if other IP addresses are set.

CLASS A: 10.0.0.0 ~ 10.255.255.255

CLASS B: 172.16.0.0 ~ 172.31.255.255

CLASS C: 192.168.0.0 ~ 192.168.255.255

#### Subnet Mask :

When connecting an xDSL modem or terminal adapter directly to the AVP-A1HDCI, input the subnet mask indicated in the documentation supplied by your provider. Normally input 255.255.255.0.

#### Default Gateway :

When connected to a gateway (router), input its IP address.

#### Primary DNS Secondary DNS :

If there is only one DNS address indicated in the documentation supplied by your provider, input it at “Primary DNS”. If there are two or more DNS addresses, input the first one at “Secondary DNS”.

- 4 Use the ▾ button to select “Exit” and press the **ENTER** button.  
Setup is complete.

※ When connecting to the network via a Proxy server, select “Proxy” and press the **ENTER** button (page 38 “Proxy settings”).



## Wireless LAN settings

Use this procedure to configure the Wireless LAN settings.

### 1 Fitting a rod antenna (☞ page 21).

※ If a LAN cable is connected, remove it.

### 2 Turn on the AVP-A1HDCI (☞ page 58).

### 3 Set the access point at the GUI menu “Manual Setup” – “Network Setup” – “Network Setup”.

When searching access points to connect automatically, refer to “Automatic settings”.

When searching access points to connect manually, refer to “Manual settings”.

#### Automatic settings

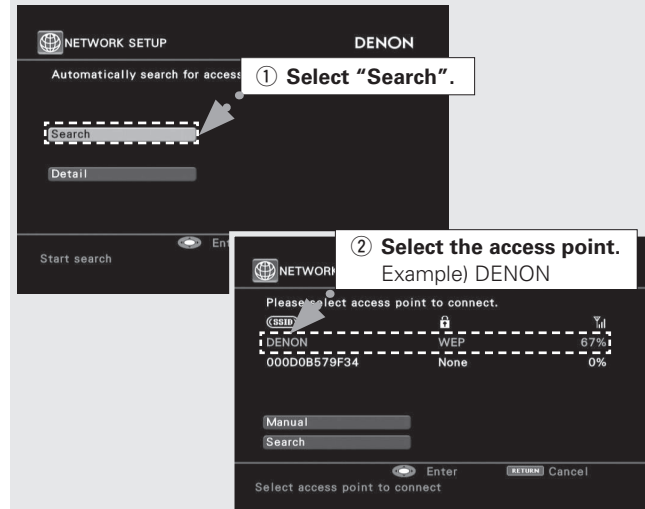

① Select “Search” and press the **ENTER** button.  
The access point you have set is displayed.

② Use the  $\Delta \nabla$  button to select the access point, and then press the **ENTER** button.

※ If the access points are not detected automatically, use the  $\nabla$  button to select the “Manual” and press the **ENTER** button. Setting becomes manual. For details, see “Manual settings” (☞ page 37).

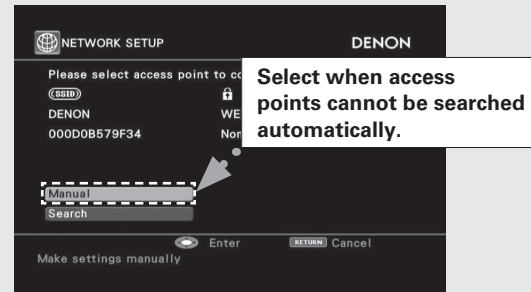

※ If the access points are repeat search, use the  $\nabla$  button to select the “Search” and press the **ENTER** button.

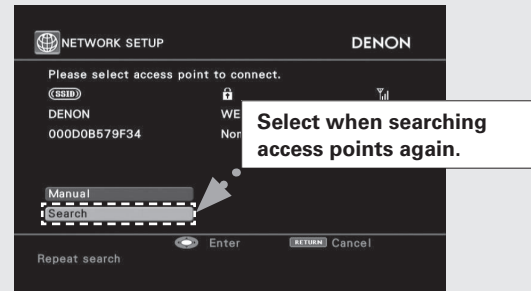

③ If there is an encryption setting for the access point you selected in step ②, enter same encryption key as used for the access point. (If there is no encryption setting, proceed to step ⑤.)

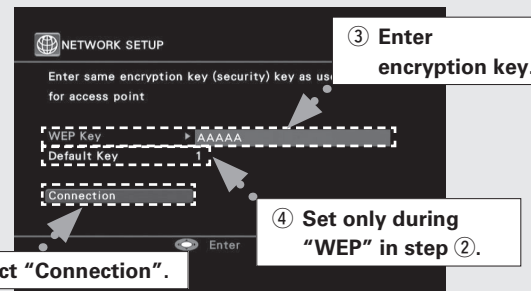

Use the  $\Delta \nabla \triangleleft \triangleright$  button to input the “Key” (encryption key) and press the **ENTER** button.

Enter the same encryption key as used for the access point.

#### [Characters that can be input]

A ~ Z a ~ z 0 ~ 9 ! " # % & ' ( ) \* + , - . / : ; < = > ? @ [ \ ] (space)

When no security settings have been used in the Internet connection settings, this step is not necessary.

④ When encryption is by “WEP”, select the “Default Key” using the  $\nabla$  button, and then press the  $\triangleleft \triangleright$  button.

[Selectable items] 1 2 3 4

Select the same default key as used for the access point. This should normally be set to “1”.

⑤ Use the  $\nabla$  button to select “Connection” and press the **ENTER** button.

Network connection starts.

When connection is established with the access point, “Connection completed.” is displayed.

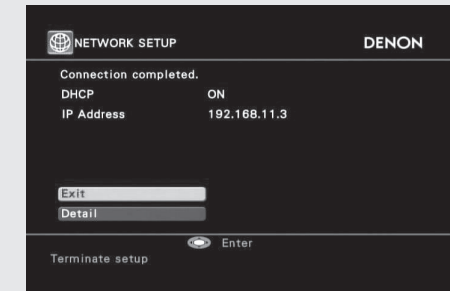

AVP-A1HDCI performs automatic network setup due to the DHCP function.

When connecting to a network that has no DHCP function, perform the setting in step 4.

## Manual settings

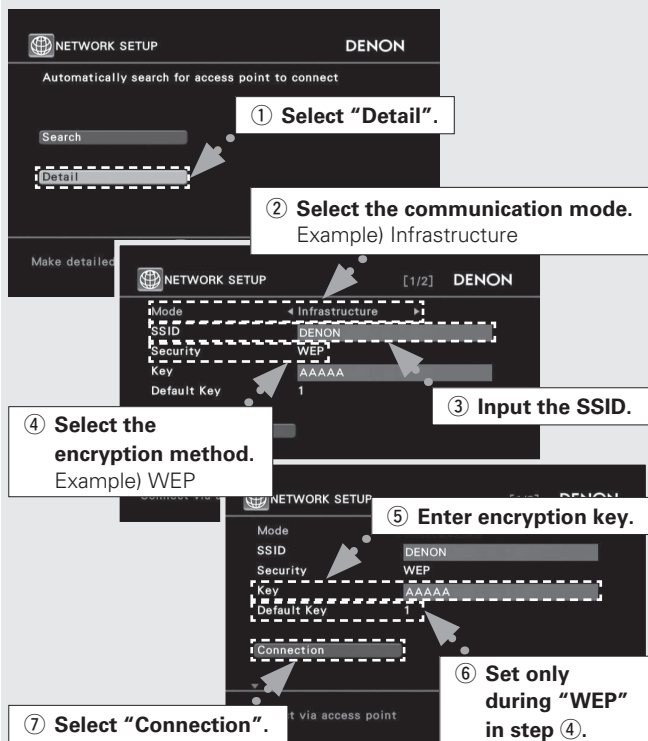

① Select "Detail" and press the **ENTER** button.

② Use the  $\triangleleft \triangleright$  button to select the Mode and press the  $\nabla$  button.

### [Selectable items]

**Infrastructure** : Select when communication is via an access point.

**Ad-hoc** : Select during direct communication, when an access point is not used.

③ Use the  $\triangle \nabla \triangleleft \triangleright$  button to input the name of the wireless network (SSID) and press the **ENTER** button.

### [Characters that can be input]

**A~Z a~z 0~9 ! " # % & ' ( ) \* + , - . / : ; < = > ? @ [ \ ] (space)**

④ Use the  $\triangle \nabla$  button to select the Security and press the  $\nabla$  button.

### [Selectable items]

**None** :

Select if not encrypted.

Can also be used even without encryption, through we recommend encryption for improved security.

**WEP WPA-PSK(TKIP) WPA-PSK(AES) WPA2-PSK(TKIP)**

**WPA2-PSK(AES)** :

Select the encryption method according to the encryption setting of the access point you are using.

⑤ Use the  $\triangle \nabla \triangleleft \triangleright$  button to input the "Key" (encryption key) and press the **ENTER** button.

Enter the same encryption key as used for the access point.

### [Characters that can be input]

**A~Z a~z 0~9 ! " # % & ' ( ) \* + , - . / : ; < = > ? @ [ \ ] (space)**

When no security settings have been used in the Internet connection settings, this step is not necessary.

⑥ When encryption is by "WEP", select the "Default Key" using the  $\nabla$  button, and then press the  $\triangleleft \triangleright$  button.

**[Selectable items] 1 2 3 4**

Select the same default key as used for the access point. This should normally be set to "1".

⑦ Use the  $\nabla$  button to select "Connection" and press the **ENTER** button.

Network connection starts.

When connection is established with the access point, "Connection completed." is displayed.

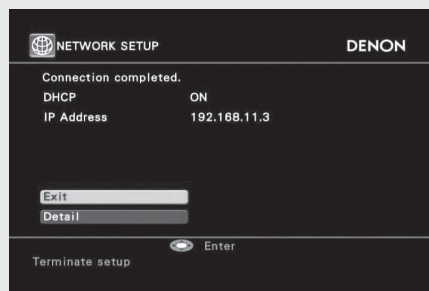

AVP-A1HDCI performs automatic network setup due to the DHCP function.

When connecting to a network that has no DHCP function, perform the setting in step 4.

## 4 Set the IP address.

※ For details, see page 35 "Wired LAN settings" in step 3.



If you are using a router with no DHCP function to automatically assign the IP address, set the IP address manually.

## Proxy settings

Make this setting when connecting to the Internet via a proxy server.

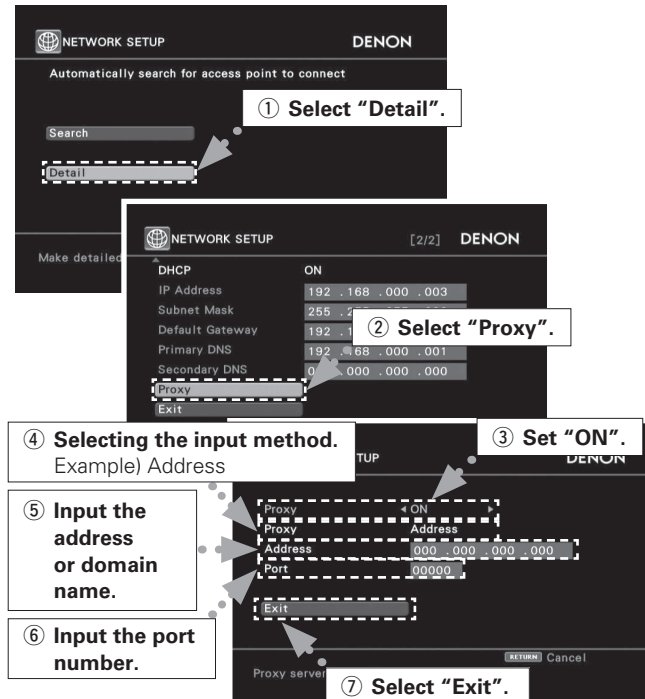

- On the GUI menu, select "Manual Setup" – "Network Setup" – "Network Setup" – "Detail" and press the **ENTER** button.
- Use the  $\Delta \nabla$  button to set "Proxy" and press the **ENTER** button.
- Use the  $\triangleleft \triangleright$  button to set "Proxy" to "ON" and press the  $\nabla$  button.  
The proxy server is enabled.
- Use the  $\triangleleft \triangleright$  button to select the proxy server input method, and then press the  $\nabla$  button.

### [Selectable items]

**Address** : Select when inputting by address.  
**Name** : Select when inputting by domain name.

- Use the  $\Delta \nabla \triangleright$  button to input the proxy server address or domain name and press the **ENTER** button.  
 When "Address" is selected in step ④ :  
 Input the address  
 When "Name" is selected in step ④ :  
 Input the domain name

### [Characters that can be input]

**A~Z** **a~z** **0~9** **! " # \$ % & ' ( ) \* + , - . / : ; < = > ? @ [ \ ] ^ \_ ` { | } ~ (space)**

- Use the  $\Delta \nabla \triangleleft \triangleright$  button to input the proxy server port number and press the **ENTER** button.
- Use the  $\nabla$  button to select "Exit" and press the **ENTER** button.  
Setup is complete.

## 2 Other

Make setting for amp power save mode and computer language environment.

## Power Saving

Make setting for power saving when not connected to network.

[Selectable items] **ON** **OFF**



To use the web control function, set this setting to "OFF".

## Character

Set the character code type of the MP3 ID3-Tag played by USB.

[Selectable items] **Auto** **Latin** **Japanese**



If the characters are not properly displayed when set to "Auto", set to "Latin" or "Japanese".

## PC Language

Select computer environment language.

[Selectable items]

**ara** **chi (simpl)** **chi (trad)** **cze** **dan** **dut** **eng** **fin**  
**fre** **ger** **gre** **heb** **hun** **ita** **jpn** **kor** **nor** **pol**  
**por** **por (BR)** **rus** **spa** **swe** **tur**

## Rhapsody Account

Set or change Username and Password.  
 "Listening to Rhapsody" (page 70)

Enter username : **Username**

### [Input characters]

**a~z** **A~Z** **0~9**

**! " # \$ % & ( ) \* + , - . / : ; < = > ? @ [ \ ] ^ \_ ` { | } ~ (space)**

Enter password : **Password**

### [Input characters]

**a~z** **A~Z** **0~9**

**! " # \$ % & ( ) \* + , - . / : ; < = > ? @ [ \ ] ^ \_ ` { | } ~ (space)**

Clear Rhapsody account : **Clear**

[Selectable items] **Yes** **No**

Merge "My Library" in the trial account with the full account : **Merge**



The Account Number received is displayed during the 30-day free trial.

## 3 Network Information

Display network information.

[Items to be checked]

**Wired or Wireless** **SSID** **DHCP= ON or OFF** **IP Address**

**MAC Address**

## Zone Setup

Make settings for audio playback in a multi-zone system.



● Menu tree ●

Manual Setup

Zone Setup

1 ZONE2

2 ZONE3

3 OSD

### 1 ZONE2

Make settings for audio playback in a ZONE2 system.

### 2 ZONE3

Make settings for audio playback in a ZONE3 system.

### Bass

Adjust low frequency range (bass).

[Variable range]  ~  ~

### Treble

Adjust high frequency range (treble).

[Variable range]  ~  ~

### HPF

When using speakers that cannot satisfactorily play low frequencies, distortion of the bass sound can be reduced by setting "HPF" to "ON".

[Selectable items]

### Lch Level

Adjust the left channel output level.

[Variable range]  ~  ~



The "Lch Level" and "Rch Level" can be set when "Channel" is set to "Stereo".

### Rch Level

Adjust the right channel output level.

[Variable range]  ~  ~

### Channel

Switch between stereo and mono output.

[Selectable items]

### Volume Level

Adjust the main volume level.

[Selectable items]

### Volume Limit

Make a setting for maximum volume.

[Selectable items]



This can be set when "Volume Level" is set to "Variable".

### Power On Level

Define the volume setting that is active when the power is turned on.

[Selectable items]



This can be set when "Volume Level" is set to "Variable".

### Mute Level

Set the amount of attenuation when muting is on.

[Selectable items]

### Video Convert (ZONE2 only)

Automatically convert video input signal to ZONE2 monitor output format.

[Input source]

[Selectable items]

### 3 OSD

Set ZONE2 monitor as onscreen display Zone.

[Selectable items]

: Display only ZONE2 operations.

: Display ZONE2 and ZONE3 operations.

#### NOTE

On-screen display appears only on the ZONE2 monitor. It does not appear on the ZONE3 monitor.

# Option Setup

Make various other settings.



## Menu tree

### Manual Setup

#### Option Setup

1 Pre-out Assign

2 XLR Out Polarity

3 POA Setting

4 Volume Control

5 Source Delete

6 GUI

7 Quick Select Name

8 Trigger Out 1

9 Trigger Out 2

10 Trigger Out 3

11 Trigger Out 4

12 Transducer Setup

13 Digital Out

14 Remote ID

15 2Way Remote

16 Dimmer

17 Setup Lock

18 Maintenance Mode

19 Firmware Update

20 Add New Feature

## 1 Pre-out Assign

Change the pre-out assignment.

Setting "Free Assign" allows you to freely assign each pre-out to any channel, depending on the environment used.

[Selectable items] **Normal** **Free Assign**

| Preout terminal \ Pre-out Assign | FL     | FR     | C      | SL (A) | SR (A) | SL (B) | SR (B) | SBL    | SBR    | SW1    | SW2    | SW3    |     |
|----------------------------------|--------|--------|--------|--------|--------|--------|--------|--------|--------|--------|--------|--------|-----|
| Normal                           | FL     | FR     | C      | SL (A) | SR (A) | SL (B) | SR (B) | SBL    | SBR    | SW1    | SW2    | SW3    |     |
| Free Assign                      | FL     | FL     | FL     | FL     | FL     | FL     | FL     | FL     | FL     | FL     | FL     | FL     |     |
|                                  | FR     | FR     | FR     | FR     | FR     | FR     | FR     | FR     | FR     | FR     | FR     | FR     |     |
|                                  | C      | C      | C      | C      | C      | C      | C      | C      | C      | C      | C      | C      |     |
|                                  | SL (A) | SL (A) | SL (A) | SL (A) | SL (A) | SL (A) | SL (A) | SL (A) | SL (A) | SL (A) | SL (A) | SL (A) |     |
|                                  | SR (A) | SR (A) | SR (A) | SR (A) | SR (A) | SR (A) | SR (A) | SR (A) | SR (A) | SR (A) | SR (A) | SR (A) |     |
|                                  | SL (B) | SL (B) | SL (B) | SL (B) | SL (B) | SL (B) | SL (B) | SL (B) | SL (B) | SL (B) | SL (B) | SL (B) |     |
|                                  | SR (B) | SR (B) | SR (B) | SR (B) | SR (B) | SR (B) | SR (B) | SR (B) | SR (B) | SR (B) | SR (B) | SR (B) |     |
|                                  | SBL    | SBL    | SBL    | SBL    | SBL    | SBL    | SBL    | SBL    | SBL    | SBL    | SBL    | SBL    | SBL |
|                                  | SBR    | SBR    | SBR    | SBR    | SBR    | SBR    | SBR    | SBR    | SBR    | SBR    | SBR    | SBR    | SBR |
|                                  | SW1    | SW1    | SW1    | SW1    | SW1    | SW1    | SW1    | SW1    | SW1    | SW1    | SW1    | SW1    | SW1 |
|                                  | SW2    | SW2    | SW2    | SW2    | SW2    | SW2    | SW2    | SW2    | SW2    | SW2    | SW2    | SW2    | SW2 |
|                                  | SW3    | SW3    | SW3    | SW3    | SW3    | SW3    | SW3    | SW3    | SW3    | SW3    | SW3    | SW3    | SW3 |



- Channels that are set up in the GUI menu "Speaker Setup"-"Speaker Configuration" to "None" can be set up, but will not generate output.
- Pre-out terminals in ZONE2 and ZONE3 can not be allocated.
- One channel can be assigned to up to 4 pre-out terminals.

## 2 XLR Out Polarity

Set to switch the XLR pre-out terminal polarity.

[Selectable channels]

Front L Front R Center Surround A L Surround A R

Surround B L Surround B R Surround Back L

Surround Back R Subwoofer 1 Subwoofer 2 Subwoofer 3

[Selectable items] XLR

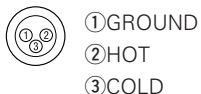

- ① GROUND
- ② HOT
- ③ COLD

XLR (INV)



- ① GROUND
- ② COLD
- ③ HOT

## 3 POA Setting

Set when connecting the receiver to a POA-A1HDCI.

### POA LINK

Set when connecting the receiver to a POA-A1HDCI through a CONTROL LINK.

[Selectable items] OFF ON (Single) ON (Dual)

## POA 1/POA 2

Set POA-A1HDCI for which the MODE select switch is set to "1" or "2".



See the POA-A1HDCI operating instructions.

### Input Selector

Select the setup channel.

[Selectable items] L1 R1 L2 R2 L3 R3  
L4 R4 L5 R5

Select the connector input to be used for each channel.

[Selectable items] RCA XLR OFF

### Power Amp

Select the setup channel.

[Selectable items] L1/L2 L3/L4 L5/R5 R1/R2 R3/R4

Set the power amp usage for each channel.

[Selectable items] NORMAL BI-AMP BRIDGE (BTL)

## LINK Check

Check CONTROL LINK.

## 4 Volume Control

Set the MAIN ZONE volume setting.

### Volume Limit

Make a setting for maximum volume.

[Selectable items] OFF -20dB -10dB 0dB

### Power On Level

This sets the volume set when the MAIN ZONE's power is turned on.

[Selectable items] Last ---dB -80dB ~ 18dB

## Mute Level

This sets the amount of attenuation of the volume when the mute mode is set in the MAIN ZONE.

[Selectable items] Full -40dB -20dB

## 5 Source Delete

Remove input sources that are not used from the display.

[Selectable items] ON Delete

### NOTE

- Input sources being used in the various zones cannot be deleted.
- Input sources set to "Delete" cannot be selected from GUI menu "Source Select" or using the **SOURCE SELECT** knob on the main unit or **SOURCE SELECT** button on the remote control unit.

## 6 GUI

Make GUI related settings.

## Screensaver

Make screensaver settings.

Use the screensaver to prevent burn-in on the monitor screen. When set to "ON", the screensaver is activated if there is no activity for about 3 minutes.

[Selectable items] ON OFF

## Wall Paper

Change the GUI background.

[Selectable items] Picture Black Gray Blue

## Format

Select the video output signal format to match the monitor.

[Selectable items] NTSC PAL

### NOTE

When a format other than the video format of the connected monitor is set, the picture will not be displayed properly. Use the procedure described below to change the video format.





## Operating from the main unit

※ The GUI menu is not displayed when performing this setting.

- Press and hold the **AUDIO DELAY** and **RETURN** buttons for at least 3 seconds.  
“Video Format” appears on the display.
- Use the <|> button to make the setting.
- Press the **ENTER**, **MENU** or **RETURN** button to complete the setting.

```
*Video Format
< NTSC >
```

### Text

Text information display.

[Selectable items] **ON** **OFF**

### Master Volume

Master volume display during adjustment.

[Selectable items] **ON** **OFF**

### NET/USB / iPod / Tuner

This sets the time the on-screen display is displayed when an operation is performed.

[Selectable items] **Always** **30s** **10s** **OFF**

## 7 Quick Select Name

Change “Quick Select” display name.  
Up to 16 characters can be input.

[Input characters]

**A~Z** **a~z** **0~9** **! " # % & ' ( ) \* + , - . / : ; < = > ? @ [ \ ] (space)**

## 8 Trigger Out 1

Select the conditions to turn on the trigger out 1 with respect to the zone, input source, surround mode, HDMI monitor, etc.  
For details about the trigger out function, see page 23.

## 9 Trigger Out 2

This sets the conditions to turn on the trigger out 2, in the same way as “Trigger Out 1” above.

## 10 Trigger Out 3

This sets the conditions to turn on the trigger out 3, in the same way as “Trigger Out 1” above.

## 11 Trigger Out 4

This sets the conditions to turn on the trigger out 4, in the same way as “Trigger Out 1” above.

[Selectable items] **ON** **---**

### Setting with Respect to the Zone

When the power of the zone turned on/off, the trigger out turns on.

### Setting with Respect to the Input Source

When the input source set to on is selected, the trigger out turns on.



Associated with respect to the input source for zones set to “ON” at “Setting with Respect to the Zone”.

### Setting with Respect to the Surround Mode

When the surround mode set to on is selected, the trigger out turns on.



This is effective when the “MAIN ZONE” has been set to “ON” for the “Setting with Respect to the Zone” and the input source which is set to “ON” has been selected for the “Setting with Respect to the Input Source”.

## Setting with Respect to the Monitor

When the HDMI monitor set to on is selected, the trigger out turns on.



This is effective when the “MAIN ZONE” has been set to “ON” for the “Setting with Respect to the Zone” and the input source which is set to “ON” has been selected for the “Setting with Respect to the Input Source”.

## 12 Transducer Setup

Set when using transducer.



The Transducer Setup can be accessed through GUI menu “Speaker Setup” – “Subwoofer Setup” is “1SP”, “2SP L/R” or “2SP MIX”. The transducer signal is outputted from “SW3”.

### Level

[Variable range]

**-12dB** ~ **0dB** ~ **+12dB** :

Set the transducer level.

**OFF** :

Turn the transducer output off.



When you adjust “Level”, the adjusted value is set for all surround modes. To adjust the level for individual surround modes, use “Channel Level” (page 75).

### LPF

Set the upper limit of the low frequency output to the transducer.

[Selectable items]

|              |              |              |             |              |              |              |
|--------------|--------------|--------------|-------------|--------------|--------------|--------------|
| <b>40Hz</b>  | <b>60Hz</b>  | <b>80Hz</b>  | <b>90Hz</b> | <b>100Hz</b> | <b>110Hz</b> | <b>120Hz</b> |
| <b>150Hz</b> | <b>200Hz</b> | <b>250Hz</b> |             |              |              |              |

### 13 Digital Out

Set usage of OPT4 OUT.

[Selectable items] **ZONE4 Select** **Rec Select**

#### NOTE

The ZONE4 operations cannot be performed when set to "Rec Select".

### 14 Remote ID

Set remote control ID.  
Match the ID setting of the remote control unit and the receiver.

[Selectable items] **1** **2** **3** **4**



- When changing the remote ID, also change the AMP, iPod, TU and NET/DTU modes of the main remote control unit at the same time (page 80).
- When changing the remote ID, also change the sub remote control unit at the same time (page 85).

### 15 2Way Remote

Set when using the 2-way remote control unit.

[Selectable items] **Used** **Not Used**



When using a 2-way remote control unit (RC-7000CI and RC-7001RCI, sold separately), set this to "Used".

#### NOTE

- When using the 2-way remote control unit, connect to the Port 1 RS-232C connector.
- If GUI menu "Manual Setup" – "Option Setup" – "2Way Remote" is set to "Used", you cannot use port 1 of the RS-232C terminal for the external controller.

### 16 Dimmer

Adjust display brightness of the receiver.

[Selectable items] **Bright** **Dim** **Dark** **OFF**



#### Operating from the main unit

Press the **DIMMER** button.



If POA-A1HDCI is connected using the control link, POA-A1HDCI meter operation is turned OFF when the AVP-A1HDCI display is turned "OFF".

### 17 Setup Lock

Protect settings from inadvertent change.

[Selectable items] **ON** **OFF**



- When "Setup Lock" is set to "ON", the settings listed below can no longer be changed. Also, "SETUP LOCKED!" is displayed if you attempt to operate related buttons.
  - GUI menu operations
  - RESTORER
  - Night Mode
  - Parameter
  - Room EQ
  - Channel Level
  - Audio Delay
- To cancel the setting, press the **MENU** button to re-display the "Setup Lock" screen, then change the setting to "OFF".

### 18 Maintenance Mode

This sets the function for maintenance by a DENON serviceperson or installer. (For professional use only.)

This function allows a DENON serviceperson or installer to check the AVP-A1HDCI's status and make settings via the Internet.

#### NOTE

Only use this function if so instructed by a DENON serviceperson or installer.

### 19 Firmware Update

Update the firmware of the receiver.



If POA-A1HDCI is connected using the control link, POA-A1HDCI is updated simultaneously with update of AVP-A1HDCI.

#### Check for Update

You can check for firmware updates. You can also check approximately how long it will take to complete an update.

#### Start

Execute the update process.

When updating starts, the power indicator becomes red and the GUI screen is shut down.

The amount of update time which has elapsed is displayed during the update process.

When updating is complete the power indicator becomes green and normal status is resumed.

※ If the display reads as shown below, check the settings and network environment, then update again.

| Display                | Description                                  |
|------------------------|--|
| <b>Updating failed</b> | Updating failed.                             |
| <b>Login failed</b>    | Failure to log into server.                  |
| <b>Server is busy</b>  | Server is busy. Wait a while then try again. |
| <b>Connection fail</b> | Failure connecting to server.                |

## 20 Add New Feature

Display the new functions which can be purchased for downloading to the AVP-A1HDCI and upgrade.

When you purchase a new function and register your user information, "Registered" is displayed on this menu and you can proceed with the upgrade.

Upon completion of the upgrade, you can start using the new function.



When "Not Registered" is displayed on the Add New Feature screen, you cannot upgrade.

To use the upgrade function, you should purchase an upgrade package from the DENON website.

To purchase the package, you will need the ID number shown on this screen.

To display the ID number on the screen, hold the **▷** and **STATUS** buttons on the main unit down for 3 seconds or more.

### Upgrade

Execute the upgrade process.

When upgrading starts, the power indicator becomes red and the GUI screen is shut down.

The amount of upgrade time which has elapsed is displayed during the upgrade process.

When upgrading is complete the power indicator becomes green and normal status is resumed.

※ If the upgrade is not successful, an error message identical to those in "Firmware Update" will appear on the display.

### Upgrade Status

A list of the additional functions provided by the Upgrade will be displayed.

## Notes concerning use of "Firmware Update" and "Add New Feature"

- In order to use these functions, you must have the correct system requirements and settings for a broadband Internet connection. For details, see pages 35 ~ 38.
- Do not turn off the power until updating or upgrading is completed.
- Normally there is no need to use this function, aside from the cases described below.
  - Firmware Update : In the case of applying the latest firmware updates (free)
  - Add New Feature : In the case of future upgrades to add new functions to the receiver (payment required)
  - Information regarding the "Firmware Update" function and "Add New Feature" will be announced on the DENON web site each time related plans are defined.
- Even with a broadband connection to the Internet, approximately 1 hour is required for the updating/upgrading procedure to be completed.

Once updating/upgrading starts, normal operations on the AVP-A1HDCI cannot be performed until updating/upgrading is completed.

Furthermore, updating/upgrading the firmware may reset the backup data for the parameters, etc., set for the AVP-A1HDCI.
- When updating/upgrading the firmware, we recommend using wired connections (Ethernet cable).

## Language

Select the language displayed on the GUI screen.



● Menu tree ●

Manual Setup

Language

[Selectable items] English Français



### Operating from the main unit

※ The GUI menu is not displayed when performing this setting.

- ① Press and hold the **AUDIO DELAY** and **RETURN** buttons for at least 3 seconds.

"Video Format" appears on the display.
- ② Use the **△▽** button to set "GUI Language".
- ③ Use the **◀▶** button to make the setting.
- ④ Press the **ENTER, MENU** or **RETURN** button to complete the setting.

```
*GUI Language  
< ENGLISH >
```

# Source Select



Use this procedure to select the input source and make the settings related to playing input sources.

## Input Source Selection

### Menu tree

#### Source Select

#### TUNER

#### PHONO

#### CD

#### DVD

#### HDP

#### TV/CBL

#### SAT

#### VCR

#### DVR-1

#### DVR-2

#### V.AUX

#### NET/USB

#### XM

#### HD Radio



## Operating from the main unit or main remote control unit

### [Operation on the main unit]

Turn the **SOURCE SELECT** knob.

※ If "Rec Select" or "Video Select" is selected, press the **SOURCE** button before turning the **SOURCE SELECT** knob.

### [Operation on the main remote control unit]

Press the **SOURCE SELECT** button.

The desired input source can be selected directly.



(Main unit)

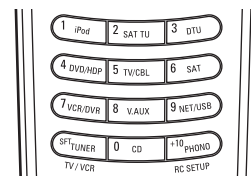

(Main remote control unit)



• To operate the AVP-A1HDCI using the main remote control unit, set the remote control unit to the AMP mode (see page 77 "Remote Control Unit Operations").

• Pressing the **DVD/HDP** button and the **VCR/DVR** button on the main remote control will switch between the following.

#### DVD/HDP :

DVD ↔ HDP

#### VCR/DVR :

VCR → DVR-1 → DVR-2

## Settings Related to Playing Input Sources



### Menu tree

#### Source Select

#### TUNER

#### 1 Play

#### 2 Auto Preset

#### 3 Preset Skip

#### 4 Preset Name

#### 5 Video

#### 6 Input Mode

#### 7 Rename

#### 8 Source Level

#### PHONO

#### 5 Video

#### 6 Input Mode

#### 7 Rename

#### 8 Source Level

#### 9 Input Att.

#### CD, DVD, HDP, TV/CBL, SAT, VCR, DVR-1, DVR-2, V.AUX

#### 1 Play \*

#### 10 Playback Mode (iPod) \*

#### 11 Assign

#### 5 Video

#### 6 Input Mode

#### 7 Rename

#### 8 Source Level

#### 9 Input Att.

#### NET/USB

#### 1 Play

#### 12 Playback Mode

#### 13 Still Picture

#### 5 Video

#### 6 Input Mode

#### 7 Rename

#### 8 Source Level

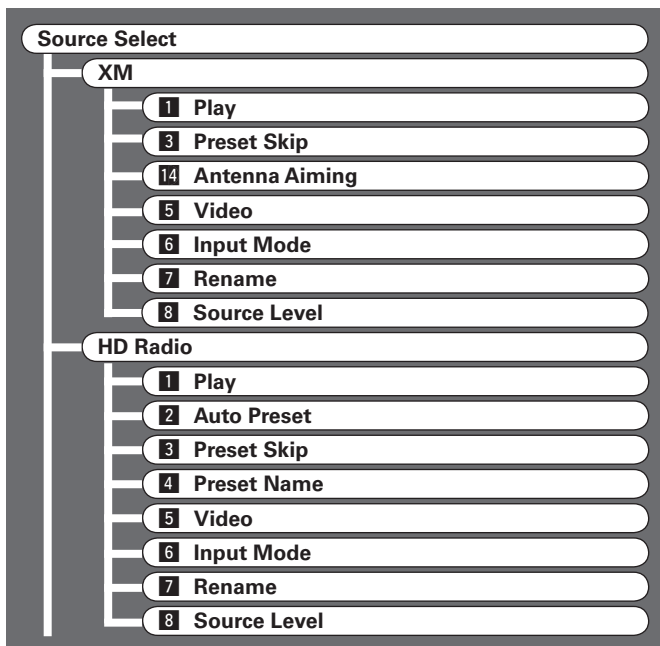

\* : "Play" and "Playback Mode (iPod)" are displayed for input sources for which "iPod dock" is assigned.

### 1 Play

The playback screen is displayed.

[Input source]

TUNER NET/USB XM HD Radio ( iPod )

### 2 Auto Preset

Use the auto preset function to program radio stations.

[Input source]

TUNER HD Radio

[Selectable items] Start



If an FM station cannot be preset automatically, select the desired station by tuning it in manually, then preset it manually.

### 3 Preset Skip

Set the preset memories that you do not want to display when tuning.

A ~ G

Select the preset channel(s) you do not want to display.

[Input source] TUNER HD Radio XM

[Selectable items] All 1 2 3 4 5 6 7 8

[Selectable items] ON Skip



When set to "All" to "Skip", it is possible to skip entire preset memory blocks (A to G).

### 4 Preset Name

Assign name to a preset memory.  
Names containing up to 8 characters can be input.

A1 ~ G8

Select the preset memory number.

[Input source] TUNER HD Radio

[Characters that can be input]

A ~ Z a ~ z 0 ~ 9 ! " # % & ' ( ) \* + , - . / : ; < = > ? @ [ \ ] (space)

### 5 Video

Setting the video source.

Video Select

Switch video input source while listening to audio signal.

[Selectable items]

DVD HDP TV/CBL SAT VCR DVR-1 DVR-2 V.AUX

SOURCE



### Operating from the main unit

Press the **VIDEO SELECT** button, then turn the **SOURCE SELECT** knob until the desired picture appears.

※ To cancel, press the main unit's **VIDEO SELECT** button, then turn the main unit's **SOURCE SELECT** knob and select "SOURCE".

NOTE

- It is not possible to select HDMI input signals.
- When playing HDMI video input signals, the analog video signal of another input source cannot be selected for the HDMI video output.
- Input sources for which "Delete" is selected at "Source Delete" cannot be selected.

Video Convert

Automatically convert video input signal to monitor output format.

[Input source]

DVD HDP TV/CBL SAT VCR DVR-1 DVR-2 V.AUX

[Selectable items] ON OFF

NOTE

- For optimum video performance, THX recommends that you set the conversion mode to "OFF" to use video signals pass through system without up conversion.  
**Example:** View video input from a component video on the component video monitor.
- When a non-standard video signal from a game machine or some other source is input, the video conversion function might not operate. If this happens, please set the conversion mode to "OFF".

i/p Scaler

Make settings for i/p scaler function.

[Selectable items] A to H A to H & H to H OFF



- This can not be set when "Video Convert" is set to "OFF".
- The "A to H & H to H" can be set to the input source assigned to the HDMI input connector.
- "A to H & H to H" setting:
  - Deep color (10 bit/12 bit) signals are converted into 8-bit signals.
  - The i/p scaler function does not work if xVCC or computer's resolution signals are input.



## Resolution

Set resolution for video signal output to HDMI.

### [Selectable items]

Auto 480p/576p 1080i 720p 1080p 1080p:24 Hz

### Operating from the main unit

Press the **SCALE** button.

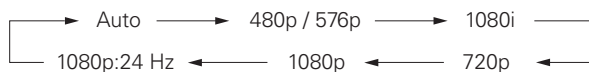

- This can be set when "i/p Scaler" is set to anything other than "OFF".
- When the "i/p Scaler" is set to "A to H & H to H", the resolutions can be setup to the analog video input signal and HDMI input signal.
- To enjoy 1080p/24 Hz video images, use a monitor which supports 1080p/24 Hz video signals.
- With film source (24 Hz), you can enjoy a film-like image. It is recommended that you use 1080p/60 Hz for video source and mixed source.
- It is not possible to convert a 50 Hz signal to 1080p/24 Hz. It is output at a resolution of 1080p/50 Hz.
- It is not possible to convert a 1080p/60 Hz signal to 1080p/24 Hz.

## Progressive Mode

Select optimum progressive mode for video material.

### [Input source]

DVD HDP TV/CBL SAT VCR DVR-1 DVR-2 V.AUX

[Selectable items] Auto Video1 Video2



This can be set when "i/p Scaler" is set to anything other than "OFF".

## Aspect

This sets the aspect ratio when outputting 480i/576i or 480p/576p input signals from the HDMI output connector.

### [Input source]

DVD HDP TV/CBL SAT VCR DVR-1 DVR-2 V.AUX  
NET/USB

[Selectable items] Full Normal



This can be set when "i/p Scaler" is set to anything other than "OFF".

## 6 Input Mode

Make input mode and decode mode settings for this source. The selectable input modes depend on the input source and "Assign" setting (page 48, 49).

### Input Mode

Set the input mode for this source.

[Input source] TUNER PHONO (iPod)

[Selectable items] Analog EXT. IN

[Input source] NET/USB XM HD Radio

[Selectable items] Auto EXT. IN

### [Input source]

CD DVD HDP TV/CBL SAT VCR DVR-1 DVR-2  
V.AUX

### [Selectable items]

Auto HDMI Digital Analog EXT. IN



When a digital signal is properly input, the "DIG." indicator lights on the display. If the "DIG." indicator does not light, check the digital input connector assignment and the connections.



## Operating from the main unit or main remote control unit

Press the **INPUT MODE** button on the main unit or the **INPUT** button on the main remote control unit.

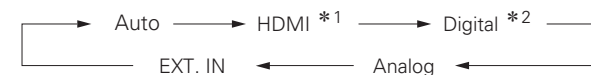

\*1: This can be selected for input sources for which the GUI menu "Assign" setting is set to "HDMI" (page 48). Excluding CD and TUNER.

\*2: This can be selected for input sources for which the GUI menu "Assign" setting is set to "Digital" (page 48).

## Decode Mode

Set the decode mode for this source.

### [Input source]

CD DVD HDP TV/CBL SAT VCR DVR-1 DVR-2 V.AUX

[Selectable items] Auto PCM DTS



- This can be selected for input sources for which the GUI menu "Assign" setting is set to "HDMI" or "Digital".
- Only set "PCM" and "DTS" when playing the respective signals.

## 7 Rename

Change the display name for this source. Names containing up to 8 characters can be input.

### [Characters that can be input]

A~Z a~z 0~9 !"#%&'()\*+,-./:;<=>?@[\\] (space)

## 8 Source Level

Corrects the playback level of the selected input source's audio input.

[Variable range] -12dB ~ 0dB ~ +12dB



For input sources for which "HDMI" or "Digital" are set at the GUI menu "Assign" setting, the analog input level and digital input level can be set separately.

## 9 Input Att.

Set when replay sound is distorted because the input level is too large.

[Selectable items] OFF -6dB



"Input Att." is effective during DSP processing of analog audio signals.

## 10 Playback Mode (iPod)

Make settings for iPod playback.

### Repeat

Make settings for repeat mode.

[Input source]

CD DVD HDP TV/CBL SAT VCR DVR-1 DVR-2  
V.AUX

[Selectable items] All One OFF

### Shuffle

Make settings for shuffle mode.

[Input source]

CD DVD HDP TV/CBL SAT VCR DVR-1 DVR-2  
V.AUX

[Selectable items] Songs Albums OFF



This can be selected for input sources for which "Assign" is assigned at the "iPod dock" setting.

## 11 Assign

Assign input sources to input connectors.

### HDMI

Select HDMI connector to assign to this source.

[Input source]

DVD HDP TV/CBL SAT VCR DVR-1 DVR-2 V.AUX

[Selectable items] 1 2 3 4 5 6 None

|                 |       |       |        |       |
|-----------------|-------|-------|--------|-------|
| Input source    | DVD   | HDP   | TV/CBL | SAT   |
| Default setting | HDMI1 | HDMI2 | None   | HDMI3 |

|                 |       |       |       |       |
|-----------------|-------|-------|-------|-------|
| Input source    | VCR   | DVR-1 | DVR-2 | V.AUX |
| Default setting | HDMI4 | HDMI5 | HDMI6 | None  |



- With an HDMI connection, video and audio signals are transmitted simultaneously. To play the video signal assigned at "HDMI" combined with the audio signal assigned at "Digital", select "Digital" at the GUI menu "Source Select" - "Input Mode" (page 47).
- When the AVP-A1HDCI and monitor are connected with an HDMI cable, if the monitor is not compatible with HDMI audio signal playback, only the video signals are output to the monitor.
- The audio signals input from the analog, digital and EXT. IN connectors are not output to the monitor.

#### NOTE

This cannot be set for input sources for which "iPod dock" is assigned.

## Digital

Select digital input connector to assign to this source.

[Input source]

CD DVD HDP TV/CBL SAT VCR DVR-1 DVR-2  
V.AUX

[Selectable items]

Coaxial1 ~ 4 Optical1 ~ 5 DENON LINK \* BNC1/2 None

\*: When a DENON DVD player and the DENON LINK have been connected, be sure to make a setting to "DENON LINK".

|                 |           |           |           |           |           |
|-----------------|-----------|-----------|-----------|-----------|-----------|
| Input source    | CD        | DVD       | HDP       | TV/CBL    | SAT       |
| Default setting | Coaxial 4 | Coaxial 1 | Coaxial 2 | Optical 1 | Coaxial 3 |

|                 |           |           |           |           |
|-----------------|-----------|-----------|-----------|-----------|
| Input source    | VCR       | DVR-1     | DVR-2     | V.AUX     |
| Default setting | Optical 4 | Optical 2 | Optical 3 | Optical 5 |

#### NOTE

This cannot be set for input sources for which "iPod dock" is assigned.

## Component

Select component video input to assign to this source.

[Input source]

DVD HDP TV/CBL SAT VCR DVR-1 DVR-2 V.AUX

[Selectable items] 1 ~ 5 - RCA 6 - BNC None

|                 |       |       |        |       |
|-----------------|-------|-------|--------|-------|
| Input source    | DVD   | HDP   | TV/CBL | SAT   |
| Default setting | 1-RCA | 2-RCA | 3-RCA  | 4-RCA |

|                 |      |       |       |       |
|-----------------|------|-------|-------|-------|
| Input source    | VCR  | DVR-1 | DVR-2 | V.AUX |
| Default setting | None | 5-RCA | None  | None  |

#### NOTE

This cannot be set for input sources for which "iPod dock" is assigned.

## Analog

Select the analog connector using the CD input.

[Input source] **CD**

[Selectable items] **RCA**

**XLR**  ①GROUND  
②HOT  
③COLD

**XLR (INV)**  ①GROUND  
②COLD  
③HOT

### NOTE

When you assign “iPod dock,” you cannot select “XLR”, or “XLR(INV)”.

## iPod dock

Assign Control Dock for iPod to this source.

[Input source]

**CD** **DVD** **HDP** **TV/CBL** **SAT** **VCR** **DVR-1** **DVR-2**

**V.AUX**

[Selectable items] **Assign** **None**



- With the default settings, the Control Dock for iPod can be used connected to the VCR (iPod) connector.
- Even if “iPod dock” is set to “Assign”, if the set is not connected to a Control dock for iPod, the input source can be used as the normal input source.

## 12 Playback Mode

Make settings for “NET/USB” playback.

[Input source] **NET/USB**

### USB Select

Select USB port to use.

[Selectable items] **Front** **Rear**



Match the port to be used and the setting.

### Repeat

Make settings for repeat mode.

[Selectable items] **All** **One** **OFF**

### Random

Make random mode settings.

[Selectable items] **ON** **OFF**

### Direct Play

Set the folder to be played using the **DIRECT PLAY** button on the sub remote control unit.

[Selectable items] **Favorites** **All Music**

## 13 Still Picture

Make settings for still picture (JPEG) playback.

[Input source] **NET/USB**

### Slide Show

Make slideshow settings.

[Selectable items] **ON** **OFF**

### Interval

Set the playback time per image.

[Variable range] **5s** ~ **60s**

## 14 Antenna Aiming

Adjust the XM radio reception sensitivity.

[Input source] **XM**

### Satellite

Indicate satellite signal strength.

### Terrestrial

Indicate terrestrial signal strength.

| Display | Condition                   |
|---------|-----------------------------|
| ■■■■■   | Signal strength is strong   |
| ■■■■    | Signal strength is good     |
| ■■■     | Signal strength is marginal |
| ■■      | Signal strength is weak     |
|         | No signal                   |

# Surround Mode



## HOME THX CINEMA

THX surround sound mode to recreate the authentic sound of movie soundtracks.

### Surround Playback of 2-channel Sources

- [Selectable items]
- PLIIx CINEMA
  - PLII CINEMA
  - Pro Logic
  - NEO:6 CINEMA

### Playing Multi-channel Sources (Dolby Digital, DTS, etc.)

- [Selectable items]
- HOME THX CINEMA
- This mode is for decoding the input signals according to their format and playing THX surround sound. The display when the HOME THX CINEMA mode is selected depends on the input signal and surround back output playback mode.

| Input signal         | Display   |                                 |                   |
|----------------------|---|---------------------------------|-------------------|
| Dolby Digital Source | DOLBY DIGITAL (other than 2ch) / DOLBY DIGITAL EX   | THX SURROUND EX                 |                   |
|                      | DOLBY DIGITAL Plus DOLBY TrueHD   | THX Ultra2 Cinema               |                   |
|                      |   | THX Music Mode                  |                   |
|                      |   | THX Games Mode                  |                   |
|                      |   | THX Cinema                      |                   |
|                      |   | PLIIx C + THX                   |                   |
| DTS Surround Source  | DTS (5.1 ch) / DTS-ES Discrete 6.1 / DTS-ES Matrix 6.1 / DTS 96/24 / DTS-HD High Resolution Audio | ES MTRX6.1 + THX (* 1)          |                   |
|                      | DTS-HD Master Audio   | ES DSCRT6.1 + THX (* 2)         |                   |
|                      |   | THX Ultra2 Cinema               |                   |
|                      | THX Music Mode  | THX Music Mode                  |                   |
|                      |   | THX Games Mode                  |                   |
|                      | THX Cinema  | THX Cinema                      |                   |
|                      |   | PLIIx C + THX                   |                   |
|                      | DVD-Audio, SACD   | PCM (multi ch) / DSD (multi ch) | THX SURROUND EX   |
|                      |   |                                 | THX Ultra2 Cinema |
|                      |   |                                 | THX Music Mode    |
| THX Games Mode       |   |                                 |                   |
| PLIIx C + THX        |   | PLIIx C + THX                   |                   |
|                      |   | M CH 5.1 + THX                  |                   |
|                      |   | M CH 7.1 + THX                  |                   |
|                      |   | M CH 7.1 + THX                  |                   |

\* 1: This is displayed when the input signal is "DTS-ES Matrix 6.1" and the AVP-A1HDCI's "AFDM" setting is set to "ON".  
 \* 2: This is displayed when the input signal is "DTS-ES Discrete 6.1".

 For details, see page 95.

 **Operating from the main unit or main remote control unit**  
 Press the **HOME THX CINEMA** button on the main unit or the **THX** button on the main remote control unit.

## Standard Playback

This is the standard mode for enjoying surround sound according to the program source.

To select these surround modes pressing the **STANDARD** button on the main unit or press the **STD** button on the main remote control unit. The mode switches each time the button is pressed.

### Surround Playback of 2-channel Sources

- When using a surround back speaker  
 [Selectable items] **DOLBY PLIIx** **DTS NEO:6** **neural**
- When not using a surround back speaker  
 [Selectable items] **DOLBY PLII** **DTS NEO:6** **neural**

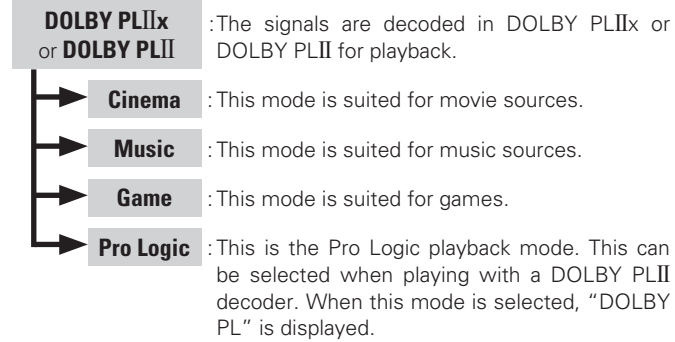

 **Operating from the main unit**  
 The "Cinema", "Music", or "Game" modes can be directly selected with the **CINEMA**, **MUSIC** or **GAME** button on the main unit.

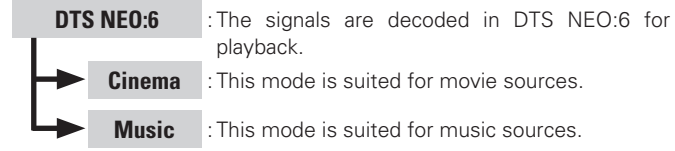

 **Operating from the main unit**  
 The "Cinema" or "Music" modes can be directly selected with the **CINEMA** button or **MUSIC** button on the main unit.

**neural** : It is possible to play analog input signals and PCM (2-channel, 48kHz or less) in the surround mode. This is the optimum mode for playing sources recorded in XM HD Surround (🔧 page 92).

 Select the "Cinema", "Music", "Game" and "Pro Logic" modes at GUI menu "Parameter" - "Audio" - "Surround Parameters" - "Mode" (🔧 page 52).

## Playing Multi-channel Sources (Dolby Digital, DTS, etc.)

### [Selectable items]

#### STANDARD :

This mode is for decoding the input signals according to their format and playing surround sound.

The display when the STANDARD mode is selected depends on the input signal and surround back output playback mode.

| Input signal          |   | Display                         |
|-----------------------|---|---------------------------------|
| Dolby Digital Source  | DOLBY DIGITAL (other than 2ch) / DOLBY DIGITAL EX                 | DOLBY DIGITAL                   |
|                       |   | DOLBY DIGITAL EX                |
|                       | DOLBY DIGITAL Plus  | DOLBY DIGITAL+PLIIx CINEMA      |
|                       |   | DOLBY DIGITAL+PLIIx MUSIC       |
| DOLBY TrueHD          | DOLBY DIGITAL +   |                                 |
| DTS Surround Source   | DTS (5.1ch) / DTS-ES Discrete 6.1 / DTS-ES Matrix 6.1 / DTS 96/24 | DTS SURROUND                    |
|                       |   | DTS+PLIIx CINEMA                |
|                       |   | DTS+PLIIx MUSIC                 |
|                       |   | DTS+NEO:6                       |
|                       |   | DTS ES MTRX6.1 (*1)             |
|                       | DTS ES DSCRT6.1 (*2)  |                                 |
|                       | DTS 96/24 (*3)  |                                 |
|                       | DTS-HD High Resolution Audio                                      | DTS-HD HI RES                   |
|                       | DTS-HD Master Audio   | DTS-HD MSTR                     |
|                       | DVD-Audio, SACD   | PCM (multi ch) / DSD (multi ch) |
| MULTI IN+PLIIx CINEMA |   |                                 |
| MULTI IN+PLIIx MUSIC  |   |                                 |
| MULTI CH IN 7.1       |   |                                 |

\*1: This is displayed when the input signal is "DTS-ES Matrix 6.1" and the AVP-A1HDCI's "AFDM" setting is set to "ON".

\*2: This is displayed when the input signal is "DTS-ES Discrete 6.1".

\*3: This is displayed when the input signal is "DTS 96/24".



For details, see page 95, 96.

## Dolby Headphone

The Dolby Headphone mode is set when headphones are connected to the **PHONES** jack while in the STANDARD (DOLBY/DTS SURROUND) mode.

### [Selectable items] DOLBY HEADPHONE



When RECOUT mode is set to "SOURCE", with this amplifier signals encoded in the Dolby Headphone mode can be output from the recording output terminals and recorded on another recorder (📖 page 73).

## DSP Simulation Playback

The desired mode according to the program source and viewing situation can be selected from among 9 DENON original surround modes.

The surround parameters can be adjusted (📖 page 93, 94) to achieve an even more realistic, powerful sound field.

### [Selectable items]

**7CH STEREO** \*1 : This mode is for enjoying stereo sound from all speakers.

**WIDE SCREEN** : This mode is for enjoying the atmosphere of viewing a movie on a large screen.

**SUPER STADIUM** : This mode is suited for viewing sports programs.

**ROCK ARENA** : This mode is for enjoying the atmosphere of a live concert in an arena.

**JAZZ CLUB** : This mode is for enjoying the atmosphere of a live concert in a jazz club.

**CLASSIC CONCERT** : This mode is for appreciating classical concert programs.

**MONO** \*2 : This mode is for playing monaural movie sources with surround sound.

**VIDEO GAME** : This mode is suited for achieving surround sound with video games.

**MATRIX** : This mode lets you add a sense of expansion to stereo music sources.

\*1: Can also be set by pressing the **7CH STEREO** button on the main unit. However, the GUI menu is not displayed.

\*2: When playing sources recorded in monaural in the MONO mode, the sound will be off balance with a single channel (left or right), so input to both channels.



- Press the **DSP SIMULATION** button on the main unit or **SIMU** button on the main remote control unit to switch the surround mode. The mode switches each time the button is pressed.
- Depending on the program source being played, it may not be possible to achieve a satisfactory surround effect. In this case, try other modes to achieve a sound field suited to your tastes.

## Stereo Playback

### [Selectable items]

#### STEREO :

This is the mode for playing in stereo. The tone can be adjusted. Sound is output from the front left and right speakers and subwoofer.



When the main unit's **DIRECT/STEREO** button or the main remote control unit's **D/ST** button is pressed, DIRECT mode can be switched to STEREO mode.



## Direct Playback

### [Selectable items]

#### DIRECT :

In this mode the signals bypass the tone control circuitry for high quality sound.

The display when the DIRECT mode is selected depends on the input signal.

For multi-channel sources, the display depends on the surround back output's play mode.

| Input signal  | Display                 |
|---|-------------------------|
| Analog signal /<br>PCM (2ch) /<br>Dolby Digital source /<br>DTS source /<br>Other 2-channel digital signals | DIRECT                  |
| DSD (2ch)   | DSD DIRECT (*)          |
| PCM (multi ch)  | MULTI CH DIRECT         |
|   | M DIRECT + PLIIx CINEMA |
|   | M DIRECT + PLIIx MUSIC  |
|   | M DIRECT 7.1            |
| DSD (multi ch)  | DSD MULTI DIRECT (*)    |

\*: When DSD signals are converted to PCM signals as set by the audio parameters and speaker settings, "DIRECT" or "MULTI CH DIRECT" is displayed.



For details, see page 96.

## Playback in the PURE DIRECT Mode

This is the mode that recreates the original sound most faithfully, providing extremely high quality sound.

**Press the PURE DIRECT button on the main unit or the PURE button on the main remote control unit.**



- To cancel, press the **PURE DIRECT** button on the main unit or the **PURE** button on the main remote control unit.
- When in the PURE DIRECT mode, the GUI screen is not displayed and the display on the main unit is turned off.
- If the HDMI input connector is selected, video outputs are output in the PURE DIRECT mode.
- The channel level and surround parameters in the PURE DIRECT mode are the same as in the DIRECT mode.



Parameters can be called out directly by pressing the **PARA** button on the main remote control unit.

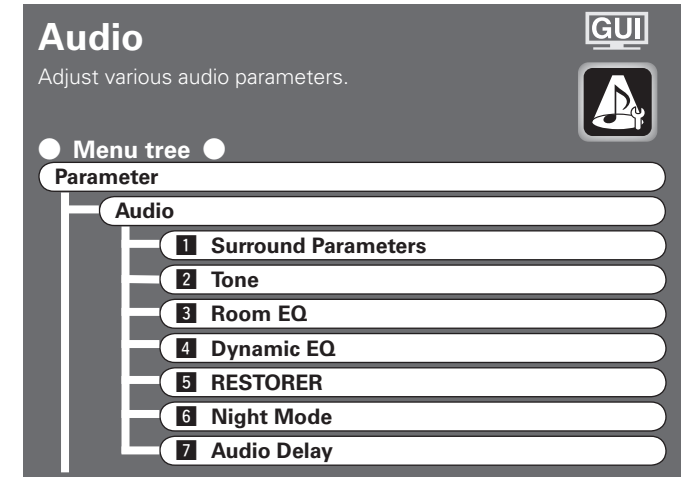

## 1 Surround Parameters

Adjust surround sound parameters.

The adjustable parameters differ for the different surround modes (page 93, 94).

## Mode

Select the mode according to the playback source.

- In the PLIIx or PLII mode

[Selectable items] **Cinema** **Music** **Game** **Pro Logic**

- In the DTS NEO:6 mode

[Selectable items] **Cinema** **Music**



The "Music" mode is also effective for movie sources including a lot of stereo music.

- In the THX mode (for 2-channel sources)

**[Selectable items]**

**Surround Back ON** **Surround Back OFF** **THX Games Mode**

- In the THX mode (for Multi-channel sources)

**[Selectable items]**

**THX Surr. EX** **ES DSCRT** **ES MTRX** **7.1+THX**

**PLIIx Cinema + THX** **THX Ultra2 Cinema** **THX Music Mode**

**THX Games Mode** **Surround Back OFF**

## Decoder

Select this when playing analog, PCM or other 2 channel sources. The signals are converted into multichannel signals using the decoders shown below and played in the Dolby Headphone mode.

- In the THX mode (for 2-channel sources)

**[Selectable items]**

**PLIIx CINEMA** **PLII CINEMA** **Pro Logic** **NEO:6 CINEMA**

- In the DOLBY HEADPHONE mode

**[Selectable items]**

**PLII CINEMA** **PLII MUSIC** **NEO:6 CINEMA**

**NEO:6 MUSIC** **OFF**

## Cinema EQ

Soften the treble range of movie soundtracks for better understanding.

**[Selectable items]** **ON** **OFF**

## DRC

Compress dynamic range (difference between loud and soft sounds).

**[Selectable items]** **Auto** **Low** **Middle** **High** **OFF**



This can be set in the Dolby TrueHD mode.

## D.COMP

Compress dynamic range (difference between loud and soft sounds).

**[Selectable items]** **OFF** **Low** **Middle** **High**



When playing DTS sources, this is only displayed for compatible software.

## LFE

Adjust the low-frequency effects level (LFE).

**[Variable range]** **-10dB** ~ **0dB**



For proper playback of the different program sources, we recommend setting to the values below.

- Dolby Digital sources: "0 dB"
- DTS movie sources: "0 dB"
- DTS music sources: "-10 dB"

## Center Image

Assign center channel signal to front left and right channels for wider sound.

**[Variable range]** **0.0** ~ **0.3** ~ **1.0**

## Panorama

Assign front L/R signal also to surround channels, for wider sound.

**[Selectable items]** **ON** **OFF**

## Dimension

Shift sound image center to front or rear, to adjust playback balance.

**[Variable range]** **0** ~ **3** ~ **6**

## Center Width

Assign center channel signal to front left and right channels for wider sound.

**[Variable range]** **0** ~ **3** ~ **7**

## Delay Time

Adjust delay time to control sound stage size.

**[Variable range]** **0 ms** ~ **30 ms** ~ **300 ms**

## Effect

Switch effect signal for multi-surround speakers on and off.

**[Selectable items]** **ON** **OFF**

## Effect Level

Adjust effect signal level.

**[Variable range]** **1** ~ **10** ~ **15**

※ Only when the surround mode is "MONO".

**[Variable range]** **0** ~ **15**



Set to a lower level if the positioning and sense of phase of the surround signals seems unnatural.

## Room Size

Determine size of acoustic environment.

**[Selectable items]**

**Small** **Medium small** **Medium** **Medium large** **Large**

**NOTE**

"Room Size" does not indicate the size of the room in which sources are played.

## AFDM

Auto-select surround mode by source.

This function only works for software containing a special identification signal.

If the software being played is recorded in Dolby Digital EX or DTS-ES, it is played in 6.1-channels. If not, it is played in 5.1-channels.

[Selectable items] **ON** **OFF**

### Example : Playing Dolby Digital software (with EX flag)

- When "AFDM" is set to "ON", the surround mode is automatically set to the DOLBY D + PLIIx C mode.
- To play in the DOLBY DIGITAL EX mode, set "AFDM" to "OFF" and "SB CH Out" to "MTRX ON".



Some Dolby Digital EX sources do not include EX flags. If the playback mode does not switch automatically even when "AFDM" is set to "ON", set "SB CH Out" to "MTRX ON" or "PLIIx CINEMA".

## SB CH Out (for Multi-channel sources)

Select playback mode for surround back channels.

[Selectable items]

**NON MTRX** **MTRX ON** **PLIIx CINEMA** \*1 **PLIIx MUSIC** \*2  
**ES MTRX** \*3 **ES DSCRT** \*4 **DSCRT ON** **OFF**

\*1: This can be selected when "Surround Back" is set to "2spkr" at the GUI menu "Manual Setup" – "Speaker Setup" – "Speaker Configuration" setting (page 29).

\*2: This can be selected when "Surround Back" is set to "2spkr" or "1spkr" at the GUI menu "Manual Setup" – "Speaker Setup" – "Speaker Configuration" setting.

\*3: This can be selected when playing DTS sources.

\*4: This can be selected when playing DTS sources including a discrete 6.1-channel signal identification signal.



When using the surround back speaker, you can change the "SB CH Out" setting by pressing the **STANDARD** button.

## SB CH Out (for 2-channel sources)

Determine whether to use surround back speakers.

[Selectable items] **ON** **OFF**

## Input Channel

Select channel using external input connectors (EXT. IN) for source being played.

[Selectable items] **8CH** **2CH**



Can be selected when GUI menu "Manual Setup" – "Audio Setup" – "EXT. IN Setup" – "Mode" is set to "DSP" (page 33).

## Subwoofer Att.

Attenuate subwoofer level when using EXT. IN input.

[Selectable items] **ON** **OFF**



Set this to "ON" if the subwoofer channel level seems too high when playing Super Audio CD.

## Subwoofer

Turn subwoofer output on and off.

[Selectable items] **ON** **OFF**

## Default

Resets the settings to the default values.

## 2 Tone

Adjust the tonal quality of the sound.

## Tone Defeat

Turn tone adjustments off.

[Selectable items] **ON** **OFF**



The tone cannot be adjusted when in the DIRECT, PURE DIRECT and HOME THX CINEMA mode.

## Bass

Adjust bass for all channels together.

[Variable range] **-6dB ~ +6dB**

## Treble

Adjust treble for all channels together.

[Variable range] **-6dB ~ +6dB**



"Bass" and "Treble" can be set when "Tone Defeat" is set to "OFF".

## Front

Adjust each front channel tone.

[Selectable items] **Bass** **Treble**

[Variable range] **-6dB ~ +6dB**

## Center

Adjust each center channel tone.

[Selectable items] **Bass** **Treble**

[Variable range] **-6dB ~ +6dB**

## Surround

Adjust each surround channel tone.

[Selectable items] **Bass** **Treble**

[Variable range] **-6dB ~ +6dB**

## Surround Back

Adjust each surround back channel tone.

[Selectable items] **Bass** **Treble**

[Variable range] **-6dB ~ +6dB**

## Subwoofer

Adjust each subwoofer channel tone.

[Selectable items] **Bass**

[Variable range] **-6dB ~ +6dB**



- This can be set individually for the separate surround mode other than PURE DIRECT, DIRECT and Home THX Cinema mode.
- When "Dynamic EQ" is set to "ON", you cannot use the "Tone" setting (page 94).

## 3 Room EQ

Select room equalizer for current environment.

[Selectable items]

**Audyssey** : Optimize frequency response of all speakers.

**Audyssey Byp. L/R** : Optimize frequency response of speakers except front L and R speakers.

**Audyssey Flat** : Optimize frequency response of all speakers to flat response.

**Manual** : Apply frequency response set with "Manual EQ" (page 34).

**OFF** : Turn equalizer off.



### Operating from the main unit or main remote control unit

Press the **ROOM EQ** button on the main unit or the **EQ** button on the main remote control.

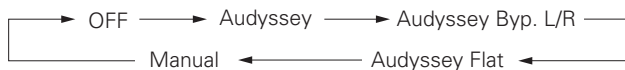

When "Audyssey" is selected, "**AUDYSSEY MULTIEQ XT**" lights.

When "Audyssey Byp. L/R" or "Audyssey Flat" is selected, or when the auto setup measuring results have changed, "**AUDYSSEY MULTIEQ XT**" lights.



- "Audyssey", "Audyssey Byp. L/R" and "Audyssey Flat" can be selected after the auto setup procedure has been performed.
- If the settings of the speakers for which "None" has been determined at "Auto Setup" are changed, "Audyssey", "Audyssey Byp. L/R" and "Audyssey Flat" cannot be selected and measurements have to be taken again to include the newly-added speakers.
- When using headphones, "Room EQ" is always set to "OFF".

## 4 Dynamic EQ

Make Dynamic EQ settings.

[Selectable items] **ON** **OFF**



### Operating from the main unit

Press the **DYNAMIC EQ** button.



- "Dynamic EQ" is displayed when selecting "Audyssey", "Audyssey Flat" or "Audyssey Byp.L/R" in the "Room EQ" setup. When set to "ON", the "**AUDYSSEY DYNAMIC EQ**" indicator is lit.

- When the audio setup measuring results have changed, "**AUDYSSEY DYNAMIC EQ**" lights.

## 5 RESTORER

This function restores compressed audio signals to how they were before compression and corrects the sense of volume of the bass and treble to obtain richer playback sound.

[Selectable items]

**OFF**

**Mode1** (RESTORER 64)

**Mode2** (RESTORER 96)

**Mode3** (RESTORER HQ)

The default setting for "NET/USB" and "iPod" is "Mode3". All others are set to "OFF".



### Operating from the main unit or main remote control unit

During playback, press the **RESTORER** button on the main unit or the **RSTR** button on the main remote control unit.

When set to something other than "OFF", "**RESTORER**" is displayed.

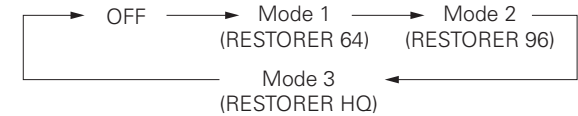

### About the RESTORER function

- Such compressed audio formats as MP3, WMA (Windows Media Audio) and MPEG-4 AAC reduce the amount of data by eliminating signal components that are hard for the human ear to hear. The RESTORER function generates the signals eliminated upon compression, restoring the sound to conditions near those of the original sound before compression. It also corrects the sense of volume of the bass to obtain richer sound with compressed audio signals.
- This is displayed on the GUI menu and can be set when the input source is set to "XM", "HD Radio" or "NET/USB", or when analog signals (including AM/FM signals) or PCM signals (fs = 44.1/48 kHz) are input.

## 6 Night Mode

Optimized setting for late-night listening.

[Selectable items] **OFF** **Low** **Middle** **High**



### Operating from the main unit or main remote control unit

Press the **NIGHT** button on the main unit or the **NGT** button on the main remote control unit.

The "**NIGHT**" indicator lights when "Low", "Middle" or "High" is selected.



## 7 Audio Delay

Compensate for mismatched timing between video and audio.

Delay audio.  
This sets the delay time for audio signals.

[Variable range]  ~



### Operating from the main unit or the main remote control unit

※ The GUI menu is not displayed when carrying out this setting.

- Press the **AUDIO DELAY** button on the main unit or **A. DL** button on the main remote control unit.
- Use the  $\triangleleft$   $\triangleright$  button to set.



- This cannot be adjusted when playing in the EXT. IN (when in analog mode), DIRECT or STEREO mode (with "Crossover Frequency" set to "FIXED-THX-", "Front" set to "Large", "Tone Defeat" to "ON" and "Room EQ" to "OFF").
- The adjustment range is 0 to 100 ms when the Auto Lipsync Correction function is activated.

## Picture Adjust

Adjust the picture quality.



### Menu tree

#### Parameter

#### Picture Adjust

- 1 Contrast
- 2 Brightness
- 3 Chroma Level
- 4 Hue
- 5 DNR
- 6 Enhancer
- 7 Sharpness

## 1 Contrast

Adjust picture contrast.

[Variable range]  ~  ~

## 2 Brightness

Adjust picture brightness.

[Variable range]  ~

## 3 Chroma Level

Adjust picture chroma level (saturation).

[Variable range]  ~  ~

## 4 Hue

Adjust color hue.

[Variable range]  ~  ~

## 5 DNR

Reduces the overall level of noise on the picture.

[Selectable items]

## 6 Enhancer

Emphasize picture contours.

[Variable range]  ~

## 7 Sharpness

Adjust color definition.

[Variable range]  ~  ~



- When the input signal is 1080p the "Picture Adjust" setting will be ineffective.
- Adjusting the "Contrast", "Brightness", "Chroma Level" and "Hue" settings does not affect the HDMI input signal.
- "Hue" can be adjusted for composite video and S-Video signals.
- The adjustment values are stored for the individual input sources.
- "DNR", "Enhancer", and "Sharpness" are each effective with HDMI output. However, they are ineffective with 480i/576i output.



## Information



### Status

Shows information about current settings.



#### Menu tree

##### Information

##### Status

- 1 MAIN ZONE
- 2 ZONE2/3/4

## 1 MAIN ZONE

Shows information about settings for MAIN ZONE.  
The items displayed differ according to the input source.

### [Items to be checked]

Select Source Name Surround Mode Input Mode Room EQ  
Dynamic EQ Video Select i/p Scaler Source Level  
Rec Select Night Mode RESTORER etc.

## 2 ZONE2/3/4

Shows information about settings for multi-zone.

### [Items to be checked]

Power Select Source Volume Level

## Audio Input Signal

GUI

Shows information about audio input signals.



### ● Menu tree ●

Information

Audio Input Signal

#### [Items to be checked]

**Surround Mode** : The currently set surround mode is displayed.

**Signal** : The input signal type is displayed.

**fs** : The input signal's sampling frequency is displayed.

**Format** : The number of channels in the input signal (front, surround, LFE) is displayed.

**Offset** : The dialogue normalization correction value is displayed.

**Flag** : "MATRIX" is displayed if the input signal has undergone matrix processing, "DISCRETE" if the input signal has undergone discrete processing.

#### Dialogue normalization function

Dialogue Normalization (Dial Norm) is a feature of Dolby Digital, which is used to keep the programs at the same average listening level so the user does not have to change the volume control between Dolby Digital programs. When playing back software which has been encoded in Dolby Digital, sometimes you may see a brief message in the front panel display which will read "Dial. Norm X dB" (X being a numeric value). The display is showing how the program level relates with THX calibration level. If you want to play the program at calibrated theatrical levels, you may wish to adjust the volume. For example, if you see the following message: "Dial. Norm + 4 dB" in the front panel display, to keep the overall output level at THX calibrated loudness, just turn down the volume control by 4 dB. However, unlike a movie theater where the playback loudness is preset, you can choose your preferred volume setting for best enjoyment.

```
Dial.Norm
Offset + 4dB
```

## HDMI Information

GUI

Shows information about HDMI input/output signals and monitor.



### ● Menu tree ●

Information

HDMI Information

1 Signal Information

2 Monitor1

3 Monitor2

### 1 Signal Information

The HDMI input/output signal information is displayed.

[Items to be checked] Resolution Color Space Pixel Depth

### 2 Monitor1

The HDMI monitor 1 information is displayed.

### 3 Monitor2

The HDMI monitor 2 information is displayed.

[Items to be checked] Interface Supported resol.

## Auto Surround Mode

GUI

Shows information about auto surround mode settings.

The surround mode for which the last memory function was used for the different input signal types is displayed.



### ● Menu tree ●

Information

Auto Surround Mode

[Items to be checked]

Analog/PCM 2ch Digital 2ch Digital 5.1ch Multi ch

## Quick Select

GUI

Shows information about "Quick Select" settings.



### ● Menu tree ●

Information

Quick Select

Quick Select 1

Quick Select 2

Quick Select 3

[Items to be checked]

Select Source Input Mode Room EQ

Auto Surround Mode setting Volume Level



For instructions on storing settings at Quick Select 1 to 3, see page 75.

## Preset Station

GUI

Shows information about preset stations.



### ● Menu tree ●

Information

Preset Station

A

B

C

D

E

F

G

[Input source] TUNER XM HD Radio NET/USB

[Items to be checked] A1 ~ G8



When the **STATUS** button on the main unit is pressed, the set's status can be checked on the display.



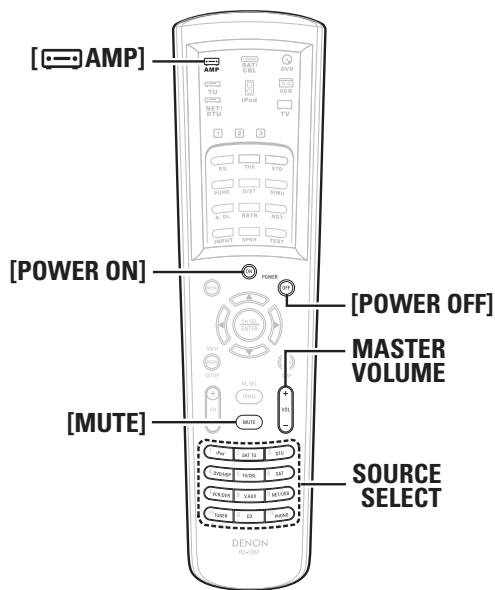
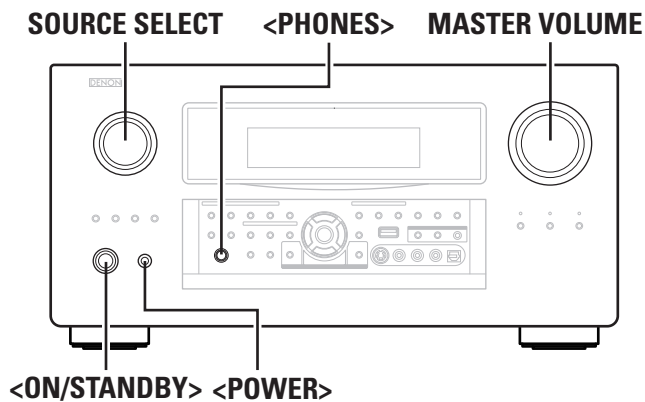

**About the button names in these explanations**  
 < > : Buttons on the main unit  
 [ ] : Buttons on the remote control unit  
**Button name only:**  
 Buttons on the main unit and remote control unit

# Playback

## Preparations

### Turning the Power On

- 1 Press <POWER>. The power indicator lights red and the power is set to the standby mode.
- 2 Press <ON/STANDBY> or [POWER ON]. The power indicator flashes green and the power turns on.

To operate the AVP-A1HDCI using the main remote control unit, set the remote control unit to the AMP mode (page 77 "Remote Control Unit Operations").

### Turning the Power Off

- 1 Press <ON/STANDBY> or [POWER OFF]. The power is set to the standby mode.
- 2 Press <POWER>. The power indicator turns off, and so does the power.

**NOTE**  
 Power continues to be supplied to some of the circuitry even when the power is in the standby mode. When leaving home for long periods of time or when traveling, either press <POWER> to turn off the power, or unplug the power cord from the power outlet.

## Operations During Playback

### Adjusting the Master Volume

Either turn <MASTER VOLUME> or press [MASTER VOLUME].

### Turning Off the Sound Temporarily (Muting)

Press [MUTE].

To cancel, press [MUTE] again. Muting can also be canceled by adjusting the master volume.

### Listening with Headphones

Plug the headphones into <PHONES>. The sound from the pre-out connectors is automatically cut.

**NOTE**  
 Be careful not to set the volume too high when using headphones.

## Playing Video and Audio Equipment

### Basic Operation

- 1 Prepare the equipment.
  - 1 Load the DVD, CD or other software in the player. (See the operating instructions of the respective devices.)
  - 2 To play a video device, switch the monitor input. (See the monitor's operating instructions.)
- 2 To operate using the main remote control unit, set the remote control unit to the AMP mode. (page 77 "Remote Control Unit Operations")
- 3 Use SOURCE SELECT to select the input source.
 

**GUI** : "Source Select" (page 45)
- 4 Start playback. (See the operating instructions of the respective devices.)

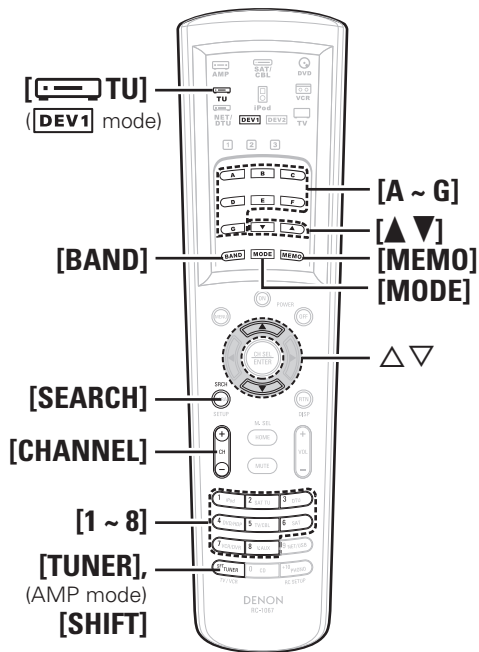
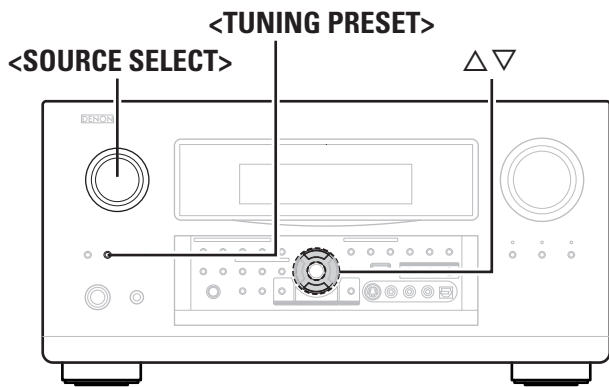

**About the button names in these explanations**

< > : Buttons on the main unit  
[ ] : Buttons on the remote control unit

**Button name only:**

Buttons on the main unit and remote control unit

**Listening to FM/AM Broadcasts**

**Basic Operation**

**1** Either turn <SOURCE SELECT> or press [TUNER] (AMP mode) to select "TUNER".

[GUI] : "Source Select" (☞ page 45)

**2** To operate using the main remote control unit, set the remote control unit to the TUNER ([DEV1] mode). (☞ page 77 "Remote Control Unit Operations")

**3** Press [BAND] to select "FM" or "AM".

**4** Tune in the desired broadcast station.

**① To tune in automatically (Auto Tuning)**

Press [MODE] to light the "AUTO" indicator on the display, then use [▲ ▼] to select the station you want to hear.

**② To tune in manually (Manual Tuning)**

Press [MODE] to turn off the display's "AUTO" indicator, then use [▲ ▼] to select the station you want to hear.



- It is also possible to switch to "FM" or "AM" in step 1 by pressing [TUNER].
- If the desired station cannot be tuned in with auto tuning, tune it in manually.
- When tuning in stations manually, press and hold [▲ ▼] to change frequencies continuously.
- The time for which the GUI menus are displayed can be set at GUI menu "Manual Setup" – "Option Setup" – "GUI" – "Tuner" (☞ page 42).

**Presetting Radio Stations (Preset Memory)**

Your favorite broadcast stations can be preset so that you can tune them in easily. Up to 56 stations can be preset.

**1** Tune in the broadcast station you want to preset.

**2** Press [MEMO].

**3** Press [A ~ G] to select the block in which the station is to be preset, then press [CHANNEL] or [1 ~ 8] to select the preset number.

※ The memory block can also be selected by pressing [SHIFT].

**4** Press [MEMO] again to complete the setting.



- To preset other stations, repeat steps 1 to 4.
- Stations can be preset automatically at GUI menu "Source Select" – "TUNER" – "Auto Preset" (☞ page 46).

**NOTE**

Preset stations are erased by overwriting them.

**Listening to Preset Stations**

**Operation on the Main Unit**

Press <TUNING PRESET>, then turn <SOURCE SELECT> to select the preset radio station.

**Operation on the Main Remote Control Unit**

☐ Recalling preset stations from the remote control unit

**1** Press [A ~ G] to select the memory block.

**2** Press [CHANNEL] or [1 ~ 8] to select the desired preset channel.

## □ Default settings

| Auto tuner presets |  |
|--------------------|--|
| A1 ~ A8            | 87.5 / 89.1 / 98.1 / 107.9 / 90.1 / 90.1 / 90.1 / 90.1 MHz |
| B1 ~ B8            | 520 / 600 / 1000 / 1400 / 1500 / 1710 kHz, 90.1 / 90.1 MHz |
| C1 ~ C8            | 90.1 MHz   |
| D1 ~ D8            | 90.1 MHz   |
| E1 ~ E8            | 90.1 MHz   |
| F1 ~ F8            | 90.1 MHz   |
| G1 ~ G8            | 90.1 MHz   |

## RDS (Radio Data System)

RDS (works only on the FM band) is a broadcasting service which allows a station to send additional information along with the regular radio program signal.

The following three types of RDS information can be received with this unit:

## Program Type (PTY)

PTY identifies the type of RDS program.

The program types and their displays are as follows:

|                  |              |                     |                 |
|------------------|--------------|---------------------|-----------------|
| <b>NEWS</b>      | News         | <b>NOSTALGA</b>     | Nostalgia       |
| <b>INFOM</b>     | Information  | <b>JAZZ</b>         | Jazz            |
| <b>SPORTS</b>    | Sports       | <b>CLASSICL</b>     | Classical       |
| <b>TALK</b>      | Talk         | <b>R &amp; B</b>    | R & B           |
| <b>ROCK</b>      | Rock         | <b>SOFT R&amp;B</b> | Soft R&B        |
| <b>CLS ROCK</b>  | Classic rock | <b>LANGUAGE</b>     | Language        |
| <b>ADLT HIT</b>  | Adult hits   | <b>REL MUSC</b>     | Religious music |
| <b>SOFT ROCK</b> | Soft rock    | <b>REL TALK</b>     | Religious talk  |
| <b>TOP 40</b>    | Top 40       | <b>PERSNLTY</b>     | Personality     |
| <b>COUNTRY</b>   | Country      | <b>PUBLIC</b>       | Public          |
| <b>OLDIES</b>    | Oldies       | <b>COLLEGE</b>      | College         |
| <b>SOFT</b>      | Soft         | <b>WEATHER</b>      | Weather         |

## Traffic Program (TP)

TP identifies programs that carry traffic announcements. This allows you to easily find out the latest traffic conditions in your area before leaving home.

## Radio Text (RT)

RT allows RDS stations to send text messages that appear on the display.

### NOTE

The operations described below using **[SEARCH]** will not function in areas in which there are no RDS broadcasts.

## RDS Search

Use this function to automatically tune to FM stations that provide the RDS service.

**1** Either turn **<SOURCE SELECT>** or press **[TUNER]** (AMP mode) to select “TUNER”.

**2** To operate using the main remote control unit, set the remote control unit to the **TUNER (DEV1)** mode.

(☞ page 77 “Remote Control Unit Operations”)

**3** Press **[SEARCH]** to select “RDS”.

**4** Press **[CHANNEL]**.

The search for RDS stations begins automatically.

※ If no RDS stations are found with the above operation, all the reception bands are searched.

※ When a broadcast station is found, that station’s name appears on the display.

**5** To continue searching, repeat steps 2 to 3.

※ If no RDS station is found when all the frequencies have been searched, “NO RDS” is displayed.

## PTY Search

Use this function to find RDS stations broadcasting a designated program type (PTY). For a description of each program type, refer to “Program Type (PTY)”.

**1** Either turn **<SOURCE SELECT>** or press **[TUNER]** (AMP mode) to select “TUNER”.

**2** To operate using the main remote control unit, set the remote control unit to the **TUNER (DEV1)** mode.

(☞ page 77 “Remote Control Unit Operations”)

**3** Press **[SEARCH]** to select “PTY”.

**4** Watching the display, press **△▽** to call out the desired program type.

**5** Press **[CHANNEL]**.

PTY search begins automatically.

※ If there is no station broadcasting the designated program type with the above operation, all the reception bands are searched.

※ The station name is displayed on the display after searching stops.

**6** To continue searching, repeat steps 2 to 4.

※ If no station broadcasting the designated program type is found when all the frequencies have been searched, “NO PROGRAMME” is displayed.

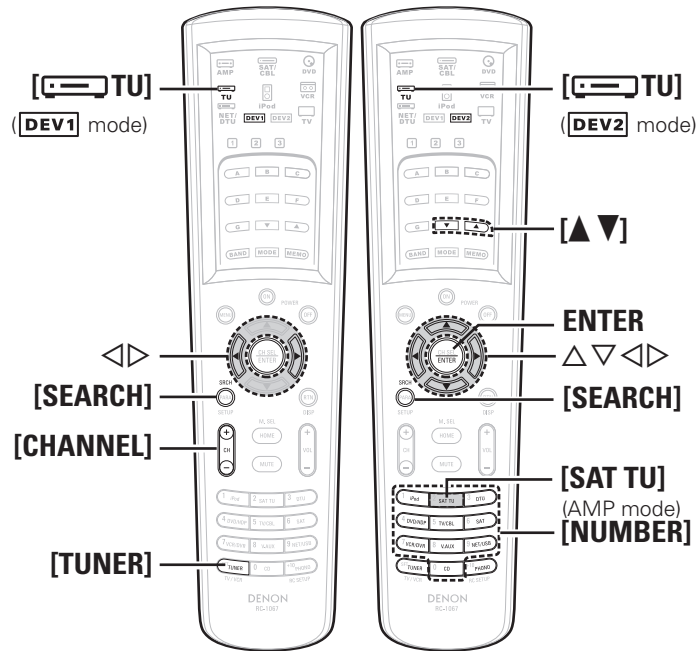
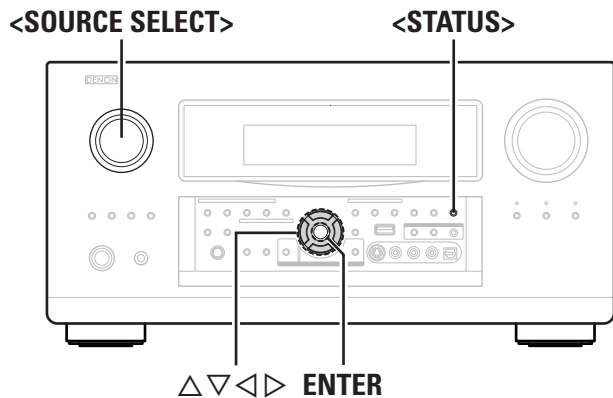

**About the button names in these explanations**  
 < > : Buttons on the main unit  
 [ ] : Buttons on the remote control unit  
**Button name only:**  
 Buttons on the main unit and remote control unit

### TP Search

Use this function to find RDS stations broadcasting traffic programs (TP stations).

- 1 Either turn <SOURCE SELECT> or press [TUNER] (AMP mode) to select “TUNER”.
- 2 To operate using the main remote control unit, set the remote control unit to the TUNER ([DEV1]) mode.  
(☞ page 77 “Remote Control Unit Operations”)
- 3 Press [SEARCH] to select “TP”.
- 4 Press [CHANNEL].  
TP search begins automatically.  
 ※ If no TP station is found with the above operation, all the reception bands are searched.  
 ※ The station name is displayed after searching stops.
- 5 To continue searching, repeat steps 2 to 3.  
 ※ If no other TP station is found when all the frequencies have been searched, “NO PROGRAMME” is displayed.

### RT (Radio Text)

“RT” appears on the display when radio text data is received.

- 1 Either turn <SOURCE SELECT> or press [TUNER] (AMP mode) to select “TUNER”.
- 2 To operate using the main remote control unit, set the remote control unit to the TUNER ([DEV1]) mode.  
(☞ page 77 “Remote Control Unit Operations”)
- 3 Press [SEARCH] to select “RT”.  
 ※ While receiving an RDS broadcast station, the text data broadcast from the station is displayed.  
 ※ To turn the display off, press ◀▷.  
 ※ If no text data is being broadcast, “NO TEXT DATA” is displayed.

## Listening to XM Satellite Radio Programs

### About XM Radio

XM is North America’s number one satellite radio company, offering an extraordinary variety of commercial-free music, plus the best in premier sports, news, talk radio, comedy, children’s and entertainment programming, broadcast in superior digital audio quality coast to coast. For more information, or to subscribe, U.S. customers visit [xmradio.com](http://xmradio.com) or call XM Listener Care at 1-800- XMRADIO (1-800-967-2346); Canadian customers visit [xmradio.ca](http://xmradio.ca) or call XM Listener Care at 1-877-GETXMSR (1-877-438-9677).

### XM Ready® Legal

XM monthly service subscription sold separately. XM Mini-Tuner and Home Dock required (each sold separately) to receive XM service. It is prohibited to copy, decompile, disassemble, reverse engineer, hack, manipulate or otherwise make available any technology or software incorporated in receivers compatible with the XM satellite Radio System. Installation costs and other fees and taxes, including a one-time activation fee may apply. All fees and programming subject to change. Channels with frequent explicit language are indicated with an XL. Channel blocking is available for XM radio receivers by calling 1-800-XMRADIO (U.S. residents) and 1-877-GETXMSR (Canadian residents). XM Service only available in the 48 contiguous United States and Canada. ©2008 XM Satellite Radio Inc. All rights reserved.

### XM Ready® Subscription

Once you have installed the XM Mini-Tuner Home Dock, inserted the XM Mini-Tuner, connected the XM Mini-Tuner Home Dock to your XM Ready® audio system, and installed the antenna, you are ready to subscribe and begin receiving XM programming. There are three places to find your eight character XM Radio ID: On the XM Mini-Tuner, on the XM Mini-Tuner package, and on XM Channel 0. Record the Radio ID below for reference.

□ □ □ □ □ □ □ □

**Note:** The XM Radio ID does not use the letters “I”, “O”, “S” or “F”. Activate your XM Satellite Radio service in the U.S. online at <http://activate.xmradio.com> or call 1-800-XMRADIO (1-800-967-2346). Activate your XM Satellite Radio service in Canada online at <https://activate.xmradio.ca> or call 1-877-GET-XMSR (1-877-438-9677). You will need a major credit card. XM will send a signal from the satellites to activate the full channel lineup. Activation normally takes 10-15 minutes, but during peak busy periods you may need to keep your XM Ready audio system on for up to an hour. When you can access the full lineup on your XM Ready audio system you are done.

## Basic Operation

- 1 Either turn <SOURCE SELECT> or press [SAT TU] (AMP mode) to select “XM”.

**GUI** : “Source Select” (☞ page 45)

- 2 To operate using the main remote control unit, set the remote control unit to the TUNER (DEV2) mode. (☞ page 77 “Remote Control Unit Operations”)

- 3 Use [▲ ▼] to select the channel. When the channel is tuned in, the name of the song and artist are displayed.



- The channel switches continuously when [▲ ▼] is pressed and held.
- XM Radio channels can be preset using the same procedure as for FM/AM stations (☞ page 59, 60 “Presetting Radio Stations (Preset Memory)” and “Listening to Preset Stations”).
- The artist name, song title, category and reception level can be checked by pressing <STATUS>.
- The time for which the GUI menus are displayed can be set at GUI menu “Manual Setup” – “Option Setup” – “GUI” – “Tuner” (☞ page 42).

## Checking the XM Signal Strength and Radio ID

- 1 Either turn <SOURCE SELECT> or press [SAT TU] (AMP mode) to select “XM”.

- 2 Press <STATUS> until “SIGNAL” appears on the display.

The display will switch as shown below, depending on the reception conditions.

| Display  | GUI | Status                      |
|----------|-----|-----------------------------|
| GOOD     |     | Signal strength is good     |
| MARGINAL |     | Signal strength is marginal |
| WEAK     |     | Signal strength is weak     |
| NO       |     | No signal                   |

- 3 Adjust the position of the antenna until “SIGNAL: GOOD” is shown on the display.

- 4 Press <STATUS> until the channel (example: “XM001”) is displayed.

- 5 Press [▲ ▼] and select channel 0 (XM000). The radio ID is shown on the display.

XM000 RADIO ID  
\*\*\*\*\* ← Radio ID



The strength of both the XM satellite and terrestrial signals can be checked at GUI menu “Source Select” – “XM” – “Antenna Aiming” (☞ page 49).

## Searching Categories

- 1 Press <◀ ▶>.

XM040 DeepTrks  
CAT: Rock ← Channel category

- 2 Use <◀ ▶> to select the category, then use [▲ ▼] to select the desired channel.

## Accessing XM Radio Channels Directly

- 1 Press [SEARCH].

- 2 Press [NUMBER] then input the channel.

**Example:** Accessing channel “XM123”:

[1] → [2] → [3]

※ If no button is pressed within several seconds, the channel automatically switches to the one whose number has been input.

- 3 Press ENTER to set that channel. Reception switches to the selected channel.



- “LOADING” is displayed while channels or data are being received.
- “XM ---” is displayed if the selected channel cannot be used.

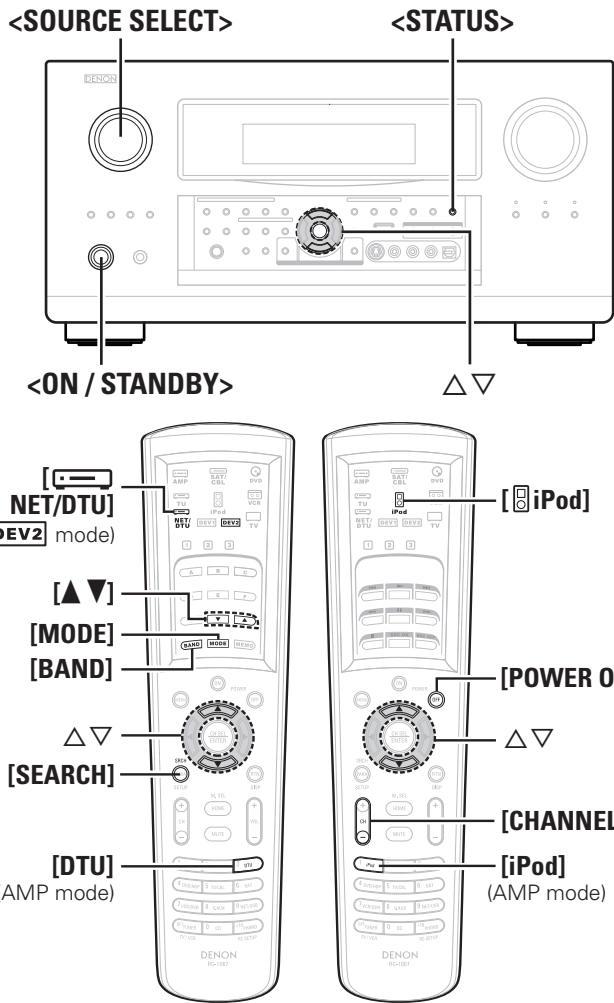

**About the button names in these explanations**

< > : Buttons on the main unit  
 [ ] : Buttons on the remote control unit  
**Button name only:**  
 Buttons on the main unit and remote control unit

## Listening to HD Radio™ Stations

HD Radio stations offer higher sound quality than conventional FM/AM broadcasts. It is also possible to receive data services and select broadcasts from among up to eight multicast programs.

### Using the HD Radio Receiver

HD Radio technology provides higher quality sound than conventional broadcasts and allows reception of data services.

- FM sounds as sensational as CDs
- AM sounds as rich as analog FM stereo
- A variety of "data services", including text-based information, song title, artist name, album name, genre, etc. can be received.

Furthermore, in addition to conventional broadcasts, with HD Radio broadcasting it is possible to choose from up to 8 multicast programs. For detailed information on HD Radio technology, please go to "www.ibiquity.com".

**HD Radio®**

HD Radio™ Technology Manufactured Under License From iBiquity Digital Corp. U.S. and Foreign Patents. HD Radio™ and the HD and HD Radio logos are proprietary trademarks of iBiquity Digital Corp.

## Basic Operation

**1** Either turn <SOURCE SELECT> or press [DTU] (AMP mode) to select "HD Radio".

**GUI** : "Source Select" (page 45)

**2** To operate using the main remote control unit, set the remote control unit to the NET/DTU ([DEV2]) mode. (page 77 "Remote Control Unit Operations")

**3** Press [BAND] to select "FM" or "AM".

**4** Tune in the desired broadcast station.

- ① To tune in automatically (Auto Tuning)**
- Press [MODE] to select "HD Auto" or "Auto", then use [▲ ▼] to select the station you want to hear.
- The "[HD]" indicator lights on the display when an HD Radio station is tuned in.
  - When "HD Auto" (tuning mode) is selected, only HD Radio stations are tuned in.
  - If "Auto" (tuning mode) is selected, both HD Radio and analog stations are tuned in.
- ② To tune in manually (Manual Tuning)**
- Press [MODE] to select "Manual", then use [▲ ▼].

- It is also possible to switch to "FM" or "AM" at step 1 by pressing [DTU].
- If the desired station cannot be tuned in with auto tuning, tune it in manually.
- When tuning in stations manually, press and hold [▲ ▼] to change frequencies continuously.
- HD Radio stations can be preset using the same procedure as for FM/AM stations (page 59, 60 "Presetting Radio Stations (Preset Memory)" and "Listening to Preset Stations"). In addition, with HD Radio technology, multicasts can also be preset.
- The time for which the GUI menu is displayed can be set at GUI menu "Manual Setup" – "Option Setup" – "GUI" – "Tuner" (page 42).



## Selecting Audio Programs

An HD Radio broadcast includes up to 8 audio programs (HD1 to HD8 and Analog). The different audio programs also have data programs.

Press **[SEARCH]** or  $\triangle \nabla$  to select the audio program.

If the station you are listening to has multiple audio programs, "HD1" is indicated on the display. If it only has one audio program, "HD" is indicated.



If an audio program from HD2 to HD8 has been interrupted, HD1 is automatically selected after about 20 seconds.

## Check the HD Radio Reception Information

Press **<STATUS>** while an HD Radio broadcast is being received.

The current reception information is shown on the display.

- ① Normal  
↓
- ② Frequency / Signal strength  
↓
- ③ Long station name / Program and Program type  
↓
- ④ Title name / Artist name  
↓
- ⑤ Album name / Genre name

### NOTE

If the station signal weakens while receiving a digital broadcast (while "HD" and text is displayed), the mode automatically switches to the analog reception mode (the reception frequency is displayed). Because of this, the "HD" indicator and text may flicker if the station signal level is weak and unstable.

### Default settings

| Tuner presets |  |
|---------------|--|
| A1 ~ A8       | 87.5 / 87.9 / 89.1 / 93.3 / 97.9 / 98.1 / 98.9 / 100.1 MHz   |
| B1 ~ B8       | 101.9 / 102.7 / 107.9 / 90.1 / 90.1 / 90.1 / 90.1 / 90.1 MHz |
| C1 ~ C8       | 530 / 600 / 930 / 1000 / 1120 / 1210 / 1400 / 1710 kHz       |
| D1 ~ D8       | 90.1 MHz   |
| E1 ~ E8       | 90.1 MHz   |
| F1 ~ F8       | 90.1 MHz   |
| G1 ~ G8       | 90.1 MHz   |

## iPod® Playback

The music on an iPod can be played by using the Control Dock for iPod (ASD-1R, sold separately). The operation can also be performed using the buttons on the main unit or remote control unit while watching the GUI menus.



iPod is a trademark of Apple Inc., registered in the U.S. and other countries.

※ The iPod may only be used to copy or play contents that are not copyrighted or contents for which copying or playback is legally permitted for your private use as an individual. Be sure to comply with applicable copyright legislation.

## Basic Operation

### 1 Make the necessary preparations.

- ① Set the iPod in the DENON Control Dock for iPod.  
(☞ See the Control Dock for iPod's operating instructions.)
- ② Assign the Control Dock for iPod's input.

**GUI** : "Source Select" – "(input source)" – "Assign" – "iPod dock" (☞ page 49)

### 2 Either turn <SOURCE SELECT> or press [iPod] (AMP mode) to select the input source assigned in step 1-② above.

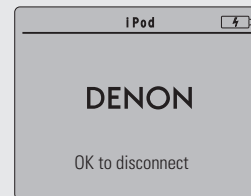

(iPod screen)

※ If the screens above are not displayed, the iPod may not be properly connected. Try connecting again.

**GUI** : "Source Select" – "(input source)" – "Play"  
(☞ page 46)

### 3 To operate using the main remote control unit, set the remote control unit to the iPod mode.

(☞ page 77 "Remote Control Unit Operations")

### 4 Press [SEARCH] and hold it down for a 2 seconds or more to select the display mode.

To switch between modes, press and hold down the button. When remote mode is active, "Remote" is displayed.

| [Display mode]   |                                  | Browse mode       | Remote mode  |
|------------------|----------------------------------|-------------------|--------------|
| Display location |                                  | Main unit display | iPod display |
| Playable files   | Audio file                       | ○                 | ○            |
|                  | Video file                       | ×                 | ○*           |
| Active buttons   | Remote control unit (AVP-A1HDCI) | ○                 | ○            |
|                  | iPod                             | ×                 | ○            |

\* : Video may not be output, depending on the combination of ASD-1R and iPod.



- With the default settings, the iPod can be used connected to the VCR (iPod) connector.
- Use the RESTORER mode to expand the low and high frequency components of compressed audio files and achieve a richer sound. The default setting is "Mode3".
- Press **<ON/STANDBY>** or **[POWER OFF]** and set the AVP-A1HDCI's power to the standby mode before disconnecting the iPod. Also switch the input source to one to which the GUI menu "iPod dock" is not assigned before disconnecting the iPod.

### NOTE

- Depending on the type of iPod and the software version, some functions may not operate.
- DENON will accept no responsibility whatsoever for any loss of iPod data.

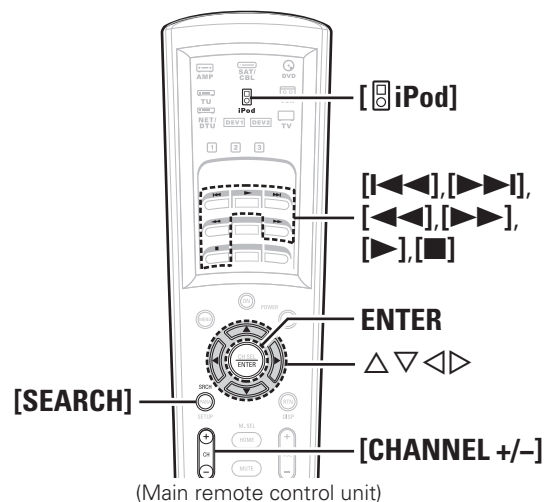
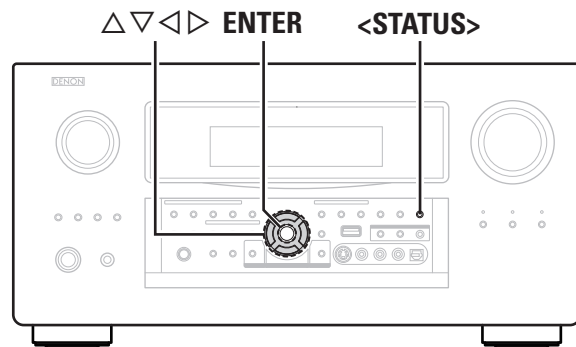

(Main remote control unit)

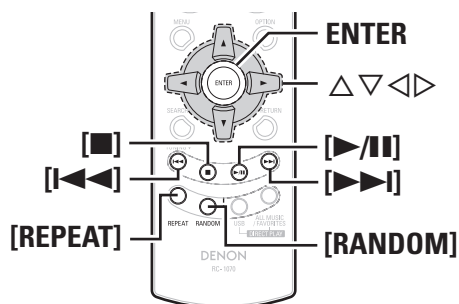

(Sub remote control unit)

**About the button names in these explanations**

< > : Buttons on the main unit

[ ] : Buttons on the remote control unit

**Button name only:**

Buttons on the main unit and remote control unit

**Listening to Music**

**1** Use Δ ▽ to select the menu, then press ENTER or ▶ to select the music file to be played.

**2** Press ENTER or ◀. Playback starts.

**To pause**

During playback, press ENTER or [▶]. Press again to resume playback.

**Fast-forwarding or fast-reversing**

During playback, either press and hold Δ (to fast-reverse) or ▽ (to fast-forward), or press [◀◀] or [▶▶].

**To cue to the beginning of a track**

During playback, either press Δ (to cue to the previous track) or ▽ (to cue to the next track), or press [◀◀] or [▶▶].

**To stop**

During playback, either press and hold ENTER or press [■].

**Playing repeatedly**

Press [CHANNEL -] or [REPEAT] on the sub remote control unit.

[Selectable items] **All** **One** **OFF**

**GUI** : "Source Select" – "(input source)" – "Playback Mode (iPod)" – "Repeat" (☞ page 48)

**Shuffling playback**

Press [CHANNEL +] or [RANDOM] on the sub remote control unit.

[Selectable items] **Albums** **Songs** **OFF**

**GUI** : "Source Select" – "(input source)" – "Playback Mode (iPod)" – "Shuffle" (☞ page 48)

**Searching up or down pages**

Press [SEARCH], then press ◀ (down) or ▶ (up). To cancel, press Δ ▽ or [SEARCH].

**To switch between the Browse and Remote modes**

Either press and hold [SEARCH].



- The title name, artist name and album name can be checked by pressing <STATUS> during playback.
- On the AVP-A1HDCI, folder and file names can be displayed as titles. Any characters that cannot be displayed are replaced with " . (period)".
- The time for which the GUI are displayed can be set at GUI menu "Manual Setup" – "Option Setup" – "GUI" – "iPod" (☞ page 42).

**Viewing Still Pictures or Videos on the iPod**

Photo and video data on the iPod can be viewed on the monitor. (Only for iPod equipped with slideshow or video functions.)

**1** Press and hold [SEARCH] to set the Remote mode. "Remote iPod" is displayed on the AVP-A1HDCI's display.

**2** Watching the iPod's screen, use Δ ▽ to select "Photos" or "Videos".

**3** Press ENTER until the image you want to view is displayed.



- "TV Out" at the iPod's "Slideshow Settings" or "Video Settings" must be set to "On" in order to display the iPod's photo data or videos on the monitor. For details, see the iPod's operating instructions.
- When unable to operate by the remote control unit, use the iPod unit.

## Playing Network Audio, USB Memory Devices or Rhapsody

This procedure can be used to play Internet radio stations or music or still picture (JPEG) files stored on a computer or USB memory device or Rhapsody.

### □ About the Internet radio function

- Internet radio refers to radio broadcasts distributed over the Internet. Internet radio stations from around the world can be tuned in.  
The AVP-A1HDCI is equipped with the following Internet radio functions:
  - Stations can be selected by genre and region.
  - Up to 56 Internet radio stations can be preset.
  - Internet radio stations in MP3 and WMA (Windows Media Audio) format can be listened to.
  - Your favorite radio stations can be registered by accessing an exclusive DENON Internet radio URL from a Web browser on a computer.
    - ※ The function is managed for individual users, so you must provide your MAC or e-mail address.  
Exclusive URL: <http://www.radiodenon.com>
    - ※ The radio station database service may be suspended without notice.
- The AVP-A1HDCI's Internet radio station list is created using a radio station database service (vTuner). This database service provides a list edited and created for the AVP-A1HDCI.

### □ Media server

This function lets you play music files and playlists (m3u, wpl) stored on a computer (media server) connected to the AVP-A1HDCI via a network.  
With the AVP-A1HDCI's network audio playback function, connection to the server is possible using one of the technologies below.

- Windows Media Player Network Sharing Service
- Windows Media DRM10

### [Album art function]

When a WMA (Windows Media Audio), MP3 or MPEG-4 AAC file includes album art data, the album art can be displayed while the music files are playing.



For music files in WMA (Windows Media Audio) format, the album art is only played when using Windows Media Player ver. 11.

### [Slide show function]

Still picture (JPEG) files stored in folders on a media server can be played as slide shows.

The time for which each picture is displayed can be set.



When still picture (JPEG) files are played on the AVP-A1HDCI, they are played in the direction in which they are stored in the folder, so store in them in the direction in which you want them to play.

#### Installing Windows Media Player ver. 11

- If Windows XP Service Pack 2 has not yet been installed, either download it free of charge from Microsoft or install it via a Windows update installer.
  - Download the latest version of Windows Media Player ver. 11, either directly from Microsoft or using a Windows update installer.
- ※ When using Windows Vista, there is no need to download a new version of Windows Media Player.

### □ USB memory devices

A USB memory device can be connected to the AVP-A1HDCI's USB port to play music and still picture (JPEG) files stored on the USB memory device.

- Only USB memory devices conforming to mass storage class and MTP (Media Transfer Protocol) standards can be played on the AVP-A1HDCI.
- The AVP-A1HDCI is compatible with USB memory devices in "FAT16" or "FAT32" format.

### [Album art function]

When an MP3 music file includes album art data, the album art can be displayed while playing the file.

### [Slide show function]

Still picture (JPEG) files stored on USB memory devices can be played as slide shows.

The time for which each picture is displayed can be set.



When still picture (JPEG) files are played on the AVP-A1HDCI, they are played in the direction in which they are stored in the folder, so store in them in the direction in which you want them to play.

### [Compatible formats]

|   | Internet radio | Media server※ | USB※ |
|---|----------------|---------------|------|
| <b>WMA</b> (Windows Media Audio)        | ○              | ○             | ○*   |
| <b>MP3</b> (MPEG-1 Audio Layer-3)       | ○              | ○             | ○    |
| <b>WAV</b>                              | —              | ○             | ○    |
| <b>MPEG-4 AAC</b>                       | —              | ○*            | ○*   |
| <b>FLAC</b> (Free Lossless Audio Codec) | —              | ○             | ○    |
| <b>JPEG</b>                             | —              | ○             | ○    |

A server or server software compatible with distribution in the corresponding formats is required to play music files via a network.

※ Only files that are not protected by copyright can be played on the AVP-A1HDCI.

Contents downloaded from pay sites on the Internet are copyright protected. Also, files encoded in WMA format when ripped from a CD, etc., on a computer may be copyright protected, depending on the computer's settings.

※ Media server and USB

- The AVP-A1HDCI is compatible with MP3 ID3-Tag (Ver. 2) standards.
- The AVP-A1HDCI is compatible with WMA META tags.

### [Playable formats]

|   | Sampling frequency | Bit rate    | Extension      |
|---|--------------------|-------------|----------------|
| <b>WMA</b> (Windows Media Audio)        | 32/44.1/48 kHz     | 48~192 kbps | .wma           |
| <b>MP3</b> (MPEG-1 Audio Layer-3)       | 32/44.1/48 kHz     | 32~320 kbps | .mp3           |
| <b>WAV</b>                              | 32/44.1/48 kHz     | —           | .wav           |
| <b>MPEG-4 AAC</b>                       | 32/44.1/48 kHz     | 16~320 kbps | .aac/.m4a/.mp4 |
| <b>FLAC</b> (Free Lossless Audio Codec) | 32/44.1/48 kHz     | —           | .flac          |

WAV format Quantization bit rate: 16 bits.

### □ Rhapsody

Rhapsody is a paid music broadcast service of RealNetworks. When you first listen to Rhapsody, take advantage of the "30-day free trial". When the free trial period has expired, it is necessary to subscribe to a Rhapsody account at the Rhapsody homepage and register this machine. See the Rhapsody homepage for details.  
[www.rhapsody.com/denon/signup](http://www.rhapsody.com/denon/signup)

<SOURCE SELECT> ENTER  $\Delta$   $\nabla$   $\triangleleft$   $\triangleright$  <STATUS>

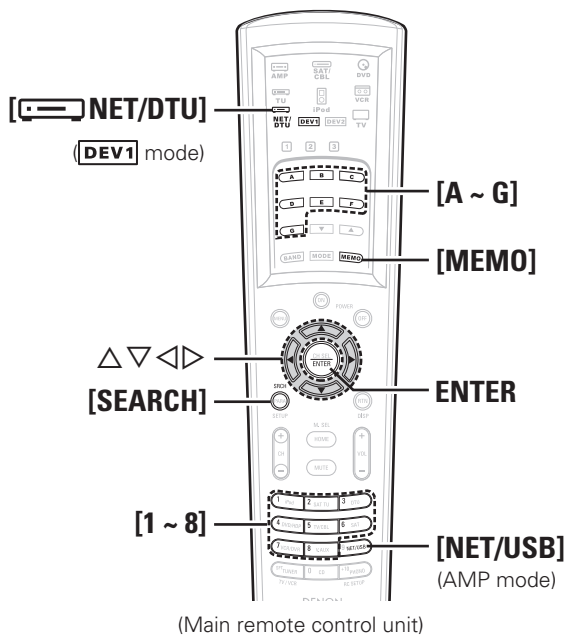
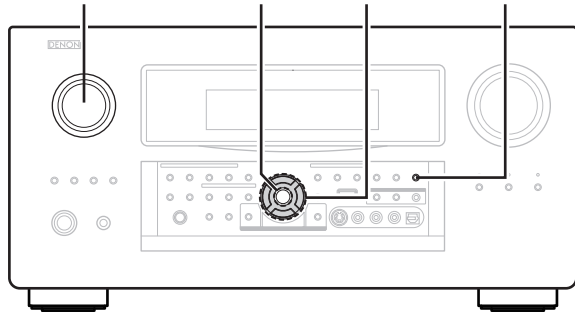

(Main remote control unit)

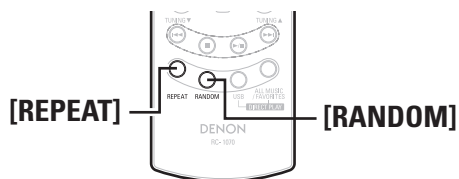

(Sub remote control unit)

**About the button names in these explanations**

< > : Buttons on the main unit  
[ ] : Buttons on the remote control unit

**Button name only:**

Buttons on the main unit and remote control unit

**Basic Operation**

**1 Make the necessary preparations.**

- ① Check the network environment, then turn on the AVP-A1HDCI's power. (☞ page 21 "Network Audio")
- ② If settings are required, make the network settings. (☞ page 35 ~ 38 "Network Setup")
- ③ Prepare the computer. (☞ Computer's operating instructions) Install "Windows Media Player ver. 11".

**2 Either turn <SOURCE SELECT> or press [NET/USB] (AMP mode) to select "NET/USB".**

**GUI** : "Source Select" – "NET/USB" – "Play"  
(☞ page 46)

**3 To operate using the main remote control unit, set the remote control unit to the NET/DTU ([DEV1]) mode.**

(☞ page 77 "Remote Control Unit Operations")

**4 Use  $\Delta$   $\nabla$  to select the menu, then press ENTER or  $\triangleright$  to select the file you want to play.**

**5 Press ENTER or  $\triangleright$ .**  
Playback starts.

**Playing repeatedly**

Press [REPEAT] on the sub remote control unit.

[Selectable items] **All** **One** **OFF**

**GUI** : "Source Select" – "NET/USB" – "Playback Mode" – "Repeat" (☞ page 49)

**Playing in random order**

Press [RANDOM] on the sub remote control unit.

[Selectable items] **ON** **OFF**

**GUI** : "Source Select" – "NET/USB" – "Playback Mode" – "Random" (☞ page 49)



The repeat mode and random mode can only be used when playing tracks recorded in USB/Media Server/Rhapsody.

**To pause**

During playback, press **ENTER**.  
Press again to resume playback.

**To stop**

During the play or pause mode, press and hold **ENTER**.

**Searching up or down pages**

Press [SEARCH], then press  $\triangleleft$  (down) or  $\triangleright$  (up).  
To cancel, press  $\Delta$   $\nabla$  or [SEARCH].

**Searching by first letter** (Character search)

This operation is convenient for choosing items from the menu screens for Internet radio stations or files stored on the computer.

① When the menu screen is displayed, press [SEARCH] twice.

② Use  $\triangleleft$   $\triangleright$  to select the first letter you want to search for.

If there are multiple items starting with the selected letter, they are displayed in alphabetical order.

If it is not possible to search the list, "unsorted list." is displayed.

To cancel, press or  $\Delta$   $\nabla$  or [SEARCH].



- Use the RESTORER mode to expand the low and high frequency components of compressed audio files and achieve a richer sound. The default setting is "Mode3".

- The time for which the GUI are displayed can be set at GUI menu "Manual Setup" – "Option Setup" – "GUI" – "NET/USB" (☞ page 42).

- Use <STATUS> to switch between displaying the title name, artist name or album name.

- The track display order differs with the server specification. When, due to the server specification, track display is not in alphabetical order, character search may not operate correctly.

## Listening to Internet Radio

- 1 Use  $\Delta$ / $\nabla$  to select “Internet Radio”, then press **ENTER** or  $\triangleright$ .
- 2 Use  $\Delta$ / $\nabla$  to select the item you want to play, then press **ENTER** or  $\triangleright$ .  
The station list is displayed.
- 3 Use  $\Delta$ / $\nabla$  to select the station, then press **ENTER** or  $\triangleright$ .  
Playback starts once buffering reaches “100%”.



- There are many Internet radio stations on the Internet, and the quality of the programs they broadcast as well as the bit rate of the tracks varies widely. Generally, the higher the bit rate, the higher the sound quality, but depending on the communication lines and server traffic, the music or audio signals being streamed may be interrupted. Inversely, lower bit rates mean a lower sound quality but less tendency for the sound to be interrupted.
- “Server Full” or “Connection Down” is displayed if the station is busy or not broadcasting.
- On the AVP-A1HDCI, folder and file names can be displayed as titles. Any characters that cannot be displayed are replaced with “.” (period).

### Recently Played Internet Radio Stations

Recently played internet radio stations can be selected from “Recently Played” in top menu.

- 1 Use  $\Delta$ / $\nabla$  to select “Recently Played”, then press **ENTER** or  $\triangleright$ .
- 2 Use  $\Delta$ / $\nabla$  to select the item you want to play, then press **ENTER** or  $\triangleright$ .

#### NOTE

Up to 20 stations stored in “Recently Played”.

## Presetting Internet Radio Stations

Preset Internet radio stations can be selected directly.

- 1 While the Internet radio station you want to preset is playing, press **[MEMO]**.
- 2 Use  $\Delta$ / $\nabla$  to select “Preset”, then press **ENTER**.
- 3 Press **[A ~ G]**, then press **[1 ~ 8]** to select the desired preset number.  
The Internet radio station is now preset.

#### NOTE

If registered at a number that has already been preset, the previously registered setting is cleared.

### Listening to Preset Internet Radio Stations

Press **[A ~ G]**, then press **[1 ~ 8]**.

The AVP-A1HDCI automatically connects to the Internet and playback begins.

## Registering Internet Radio Stations as Your Favorites

Favorites are listed at the top of the menu screen, so when a station is registered as a favorite it can be tuned in easily.

- 1 Press **[MEMO]** while the Internet radio station you want to register is playing.
- 2 Use  $\Delta$ / $\nabla$  to select “Favorites”, then press **ENTER**.
- 3 Press  $\triangleleft$  to select “Yes”.  
The Internet radio station is registered.  
If you do not want to register it, press  $\triangleright$ .

### Listening to Internet Radio Stations Registered in Your Favorites

- 1 Use  $\Delta$ / $\nabla$  to select “Favorites”, then press **ENTER** or  $\triangleright$ .
- 2 Use  $\Delta$ / $\nabla$  to select the Internet radio station, then press **ENTER** or  $\triangleright$ .  
The AVP-A1HDCI automatically connects to the Internet and playback begins.

### Clearing Internet Radio Stations from Your Favorites

- 1 Use  $\Delta$ / $\nabla$  to select “Favorites”, then press **ENTER** or  $\triangleright$ .
- 2 Use  $\Delta$ / $\nabla$  to select the Internet radio station you want to clear, then press **[MEMO]**.
- 3 Press  $\triangleleft$  to select “Delete”.  
The selected Internet radio station is cleared.  
To cancel the operation without clearing the station, press  $\triangleright$ .



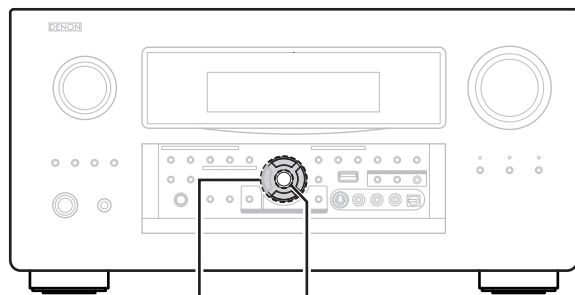

△ ▽ ▷ ENTER

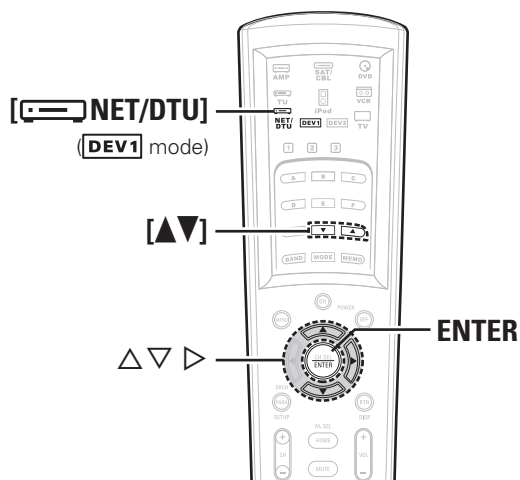

(Main remote control unit)

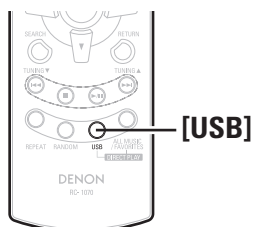

(Sub remote control unit)

#### About the button names in these explanations

< > : Buttons on the main unit  
[ ] : Buttons on the remote control unit

#### Button name only:

Buttons on the main unit and remote control unit

## Playing Files Stored on a Computer

Use this procedure to play music files, image files or playlists.

- 1 Use △ ▽ to select “Media Server”, then press ENTER or ▷.
- 2 Use △ ▽ to select the host name of the computer on which the music file you want to play is located, then press ENTER or ▷.
- 3 Use △ ▽ to select the search item or folder, then press ENTER or ▷.
- 4 Use △ ▽ to select the file, then press ENTER or ▷. Playback starts once buffering reaches “100%”.

### Selecting tracks

During playback, either press △ (previous track) or ▽ (next track).



- When playing still picture (JPEG) files, files can also be selected using the operation described below. During playback, either press [▲] (previous file) or [▼] (next file).
- Connections to the required system and specific settings must be made in order to play music files (page 21).
- Before starting, you must launch the computer’s server software and set the files as server contents. For details, see the operating instructions of your server software.
- Depending on the size of the still picture (JPEG) file, some time may be required for the file to be displayed.

### Playing files that have been Preset or Registered in Your Favorites

Files can be preset, registered in your favorites and played using the same operations as for Internet radio stations.

#### NOTE

- Presettings are erased by overwriting them.
- When the operation described below is performed, the media server’s database is updated and it may no longer be possible to play preset or favorite music files.
  - When you quit the media server and then restart it.
  - When music files are deleted or added on the media server.
- When using an ESCIENT server, place “ESCIENT” before the server name.

## Playing Files Stored on USB Memory Devices

Only USB memory devices conforming to mass storage class and MTP (Media Transfer Protocol) standards can be played on the AVP-A1HDCI.

### Basic Operation

- 1 Make the necessary preparations.

- Set the USB port to be used.

**GUI** : “Source Select” – “NET/USB” – “Playback Mode” – “USB Select” (page 49)

- Connect the USB memory device to the set USB port.

- 2 Use △ ▽ to select “USB”, then press ENTER or ▷.

- 3 Use △ ▽ to select the search item or folder, then press ENTER or ▷.

- 4 Use △ ▽ to select the file, then press ENTER or ▷. Playback starts once buffering reaches “100%”.



- By default, the front panel’s USB port will be used.
- Depending on the size of the still picture (JPEG) file, some time may be required for the file to be displayed.

### Selecting tracks

During playback, either press △ (previous track) or ▽ (next track).



- When playing still picture (JPEG) files, tracks can also be selected using the operation described below. During playback, either press [▲] (previous file) or [▼] (next file).
- If the USB memory device is divided into multiple partitions, only the top partition can be selected.
- The AVP-A1HDCI is compatible with MP3 files conforming to “MPEG-1 Audio Layer-3” standards.
- When [USB] is pressed, playback starts from the first track on the USB memory device.



## NOTE

- The AVP-A1HDCI is equipped with two USB ports, one each on the front and rear panels. It is not possible to use the set with USB memory devices connected to both the ports at the same time. Select the USB port you want to use at the "Source Select" – "NET/USB" – "Playback Mode" – "USB Select" menu.
- DENON will accept no responsibility whatsoever for any loss or damage to data on USB memory devices when using the USB memory device connected to the AVP-A1HDCI.
- USB memory devices will not work via a USB hub.
- DENON does not guarantee that all USB memory devices will operate or receive power. When using a USB connection type portable hard disk of the type for which power can be supplied by connecting an AC adapter, we recommend using the AC adapter.
- It is not possible to connect and use a computer via the AVP-A1HDCI's USB port using a USB cable.
- The AVP-A1HDCI is not compatible with the iPod shuffle.

## Listening to Rhapsody

### Preparations

- 1 Use  $\Delta \nabla$  to select "Rhapsody", then press **ENTER** or  $\triangleright$ .
- 2 Use  $\Delta \nabla$  to select "I have a Rhapsody account" or "Start 30-day free trial", then press **ENTER** or  $\triangleright$ .
- 3
  - ① When selecting "I have a Rhapsody account" Enter Username and Password. Select "OK", then press **ENTER**.
  - ② When selecting "Start 30-day free trial" Select "Accept" then press **ENTER**.  
※ To cancel, select "Reject", then press **ENTER**.

□ Username : \_\_\_\_\_

#### [Input characters]

a ~ z A ~ Z 0 ~ 9

! " # \$ % & ( ) \* + , - . / : ; < = > ? @ [ \ ] ^ \_ ` { | } ~ (space)

□ Password : \_\_\_\_\_

#### [Input characters]

a ~ z A ~ Z 0 ~ 9

! " # \$ % & ( ) \* + , - . / : ; < = > ? @ [ \ ] ^ \_ ` { | } ~ (space)

## NOTE

- The password should be no longer than 99 characters.
- The password may not contain underscores ( \_ ).

### Search From Rhapsody Latest Information

- 1 Use  $\Delta \nabla$  to select "Rhapsody Music Guide", then press **ENTER** or  $\triangleright$ .
- 2 Use  $\Delta \nabla$  to select the information for track selection, then press **ENTER** or  $\triangleright$ .  
After selecting, the information is displayed.
- 3 Use  $\Delta \nabla$  to select the track, then press **ENTER** or  $\triangleright$ .

### Enter a Character Search For the Track You Want to Listen to

- 1 Use  $\Delta \nabla$  to select "Search", then press **ENTER** or  $\triangleright$ .
- 2 Use  $\Delta \nabla$  to select the search item, then press **ENTER** or  $\triangleright$ .  
The search display appears.  
※ You can search by artist name, album name or track name.
- 3 Enter the characters, then press **ENTER**.

### Search From the Rhapsody Internet Radio Station

- 1 Use  $\Delta \nabla$  to select "Rhapsody Channels", then press **ENTER** or  $\triangleright$ .
- 2 Use  $\Delta \nabla$  to select radio station, then press **ENTER** or  $\triangleright$ .

## Registering Tracks in My Library

- 1 Press  $\triangleright$  while the track you wish to register is playing.
- 2 Use  $\Delta \nabla$  to select "Add to My Library", then press **ENTER**.  
The track is entered in the Library.

### □ Listening to Tracks Registered In My Library

- 1 Use  $\Delta \nabla$  to select "My Library", then press **ENTER** or  $\triangleright$ .
- 2 Use  $\Delta \nabla$  to select the information or track, then press **ENTER**.  
After selecting, the information is displayed.

### Displaying the Track Menu During Play

- 1 Press  $\triangleright$  during playback.
- 2 Use  $\Delta \nabla$  to select the search item, then press **ENTER** or  $\triangleright$ .

## Operating the AVP-A1HDCI Using a Browser (Web control)

This function lets you operate the AVP-A1HDCI using Internet Explorer.

**1** Switch “OFF” the “Power Saving” setting under “Manual Setup” – “Network Setup” – “Other” on the GUI menu (☞ page 38).

**2** Check the AVP-A1HDCI’s IP address with “Manual Setup” – “Network Setup” – “Network Information” on the GUI menu (☞ page 38).

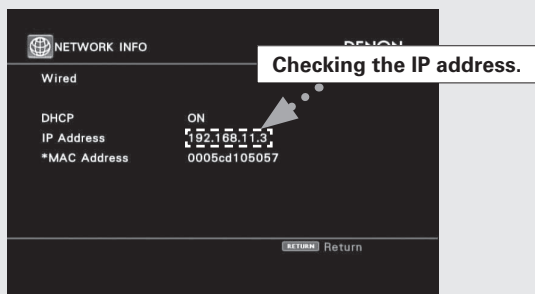

**3** Enter the AVP-A1HDCI IP address in Internet Explorer’s address box.

For example, if the IP address of AVP-A1HDCI is “192.168.11.3”, enter “http://192.168.11.3”.

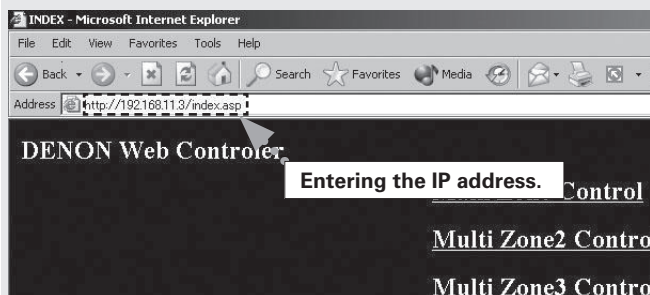

**4** When the top menu is displayed, click on the menu you want to operate.

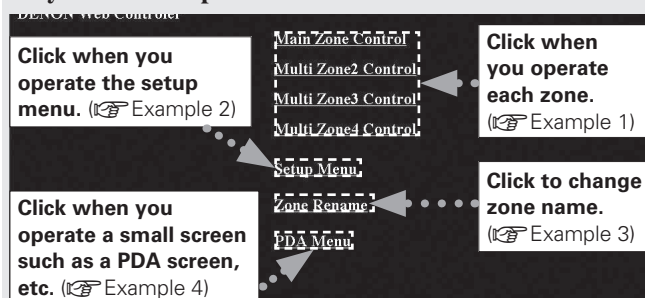

**5** Operate.

[Example 1] Main zone control screen

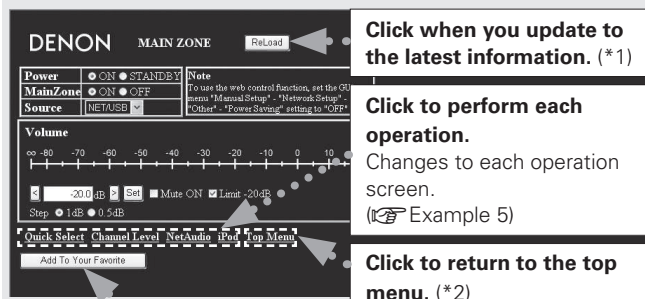

Click to add a setting to the “Favorites” in your browser. (\*3)

\*1 : Normally, there is a change to the latest information each time you operate. When operated from the main unit, click because the screen is not updated.

\*2 : Displayed when setting “Top Menu Link Setup” to “ON” in [Example 3].

\*3 : To avoid mistakenly performing menu operations of a zone you are not operating, we recommend that you register the setting contents for each zone under Favorites in your browser.

[Example 2] Setup menu screen

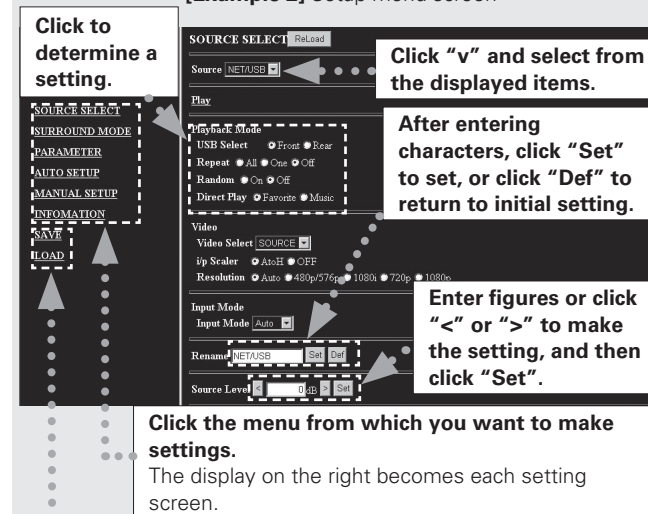

Click “SAVE” when you want to save settings, and click “LOAD” when you want to call settings. Becomes each operation screen.

[Example 3] Zone name change screen

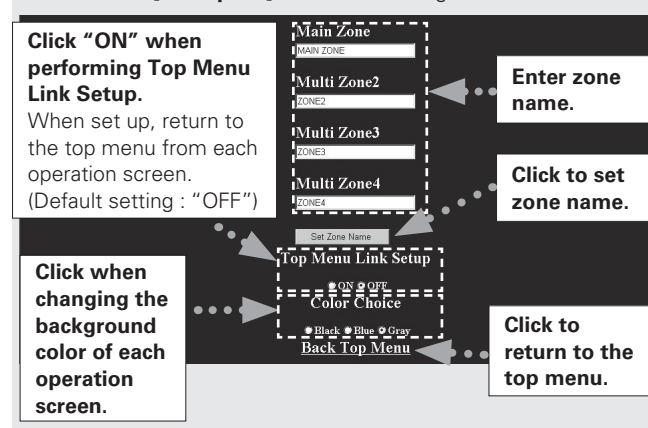

[Example 4] PDA menu screen

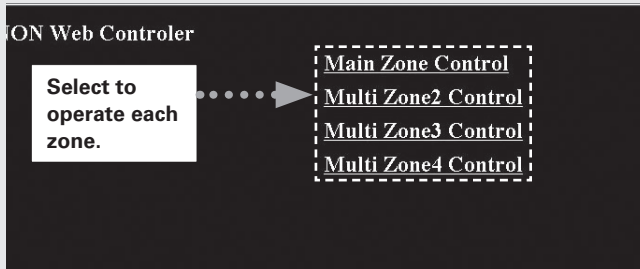

**NOTE**

You cannot change setup menu operations and zone name on the PDA menu screen.

[Example 5] Net Audio operating screen

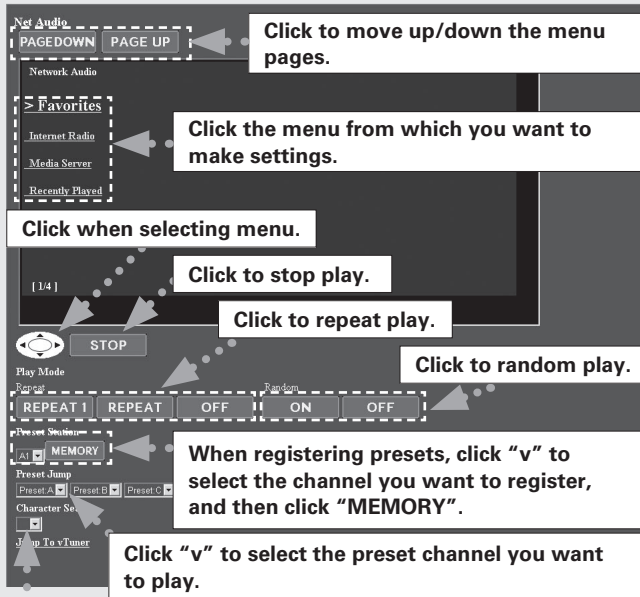

**NOTE**

- To perform web control, you must connect a web control device such as a PC to the same network as the AVP-A1HDCI.
- With web control, some network settings, etc., cannot be set.
- When updating firmware, settings made by the web controller may be reset.

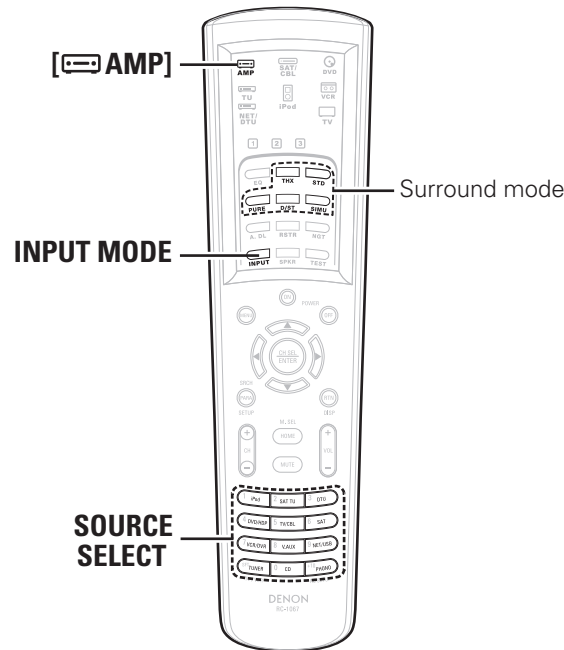
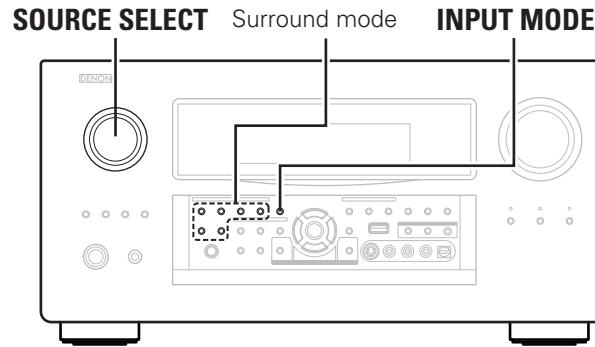

**About the button names in these explanations**  
 < > : Buttons on the main unit  
 [ ] : Buttons on the remote control unit  
**Button name only:**  
 Buttons on the main unit and remote control unit

# Other Operations and Functions

## Other Operations

### Playing Super Audio CD

- 1 Assign "DENON LINK" with the "Digital" setting or assign "HDMI" with the "HDMI" setting (page 48).
- 2 Either turn <SOURCE SELECT> or press [SOURCE SELECT] to select the input source assigned in step 1. The "D.LINK" or "HDMI" indicator lights on the display.
- 3 Select "AUTO" for the INPUT MODE (page 47).
- 4 Select the surround mode (page 50 ~ 52). We recommend playing in the DIRECT mode.
- 5 Start playing the Super Audio CD. The "DSD" indicator lights on the display. For operating instructions, refer to the respective equipment's operating instructions.

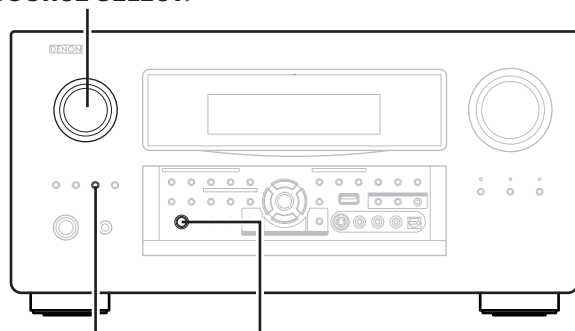

- When playing DSD signals in the DIRECT or PURE DIRECT mode, the DSD signals are converted as such into analog signals. When playing in other surround modes, the DSD signals are first converted into PCM format, then into analog signals.
- "DSD DIRECT" is shown on the display when playing DSD 2-channel signals in the DIRECT mode. "DSD MULTI DIRECT" is shown on the display when playing DSD multi-channel signals in the DIRECT mode.
- The DSD signal may not be output depending on the equipment that is connected. For further details, refer to the user manual for the equipment being used.

**<SOURCE SELECT>**

**<ZONE2/3/4 /  
REC SELECT>**   **<PHONES>**

**About the button names in these explanations**

< > : Buttons on the main unit

[ ] : Buttons on the remote control unit

**Button name only:**

Buttons on the main unit and remote control unit

**Recording on an External Device  
(REC OUT mode)**

You can listen to one program source while recording a different program source.

**1** Press **<ZONE2/3/4 / REC SELECT>**.  
"ZONE3 SOURCE" is shown on the display.

**2** Turn **<SOURCE SELECT>** until **"RECOUT SOURCE"** is displayed.

The "REC" indicator lights.

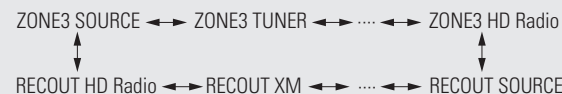

**3** Turn **<SOURCE SELECT>** to choose the input source to be recorded.

**4** Play the program source.

For operating instructions, refer to the respective equipment's operating instructions.

To record FM or AM broadcasts, select the broadcast (page 59).

**5** Start recording.

For operating instructions, refer to the respective equipment's operating instructions.



- To cancel, press **<ZONE2/3/4 / REC SELECT>**, then turn **<SOURCE SELECT>** until "ZONE3 SOURCE" is displayed.
- Make a test recording before starting the actual recording.
- Signals are only output to the analog REC OUT connectors when the digital signals input to the digital input connectors (OPTICAL/COAXIAL) are PCM (2-channel) signals.
- Digital audio signals input to the DENON LINK or HDMI connectors are not output to the REC OUT connectors, so connect using the OPTICAL or COAXIAL connectors.
- Sources selected with the REC OUT mode are output from ZONE3 as well.
- In the REC OUT mode, the remote control unit's ZONE3 mode buttons cannot be operated.
- When the "Digital Out" setting is set to "ZONE4 Select", the OPTICAL4 output connector becomes the ZONE4 output. When using for recording, set to "Rec Select".
- Copyright protected network audio (Internet radio, media server, USB and Rhapsody) signals cannot be output from the digital output connectors (OPTICAL).

**NOTE**

- Recordings you make are for your personal enjoyment and should not be used for other purposes without permission of the copyright holder.
- When "DENON LINK" is assigned at the GUI menu "Assign" setting, the PCM signals, network audio signals (Internet radio, media server, USB and Rhapsody), XM signals and HD Radio signals input from the digital input connectors cannot be output from the analog REC OUT connectors.
- Input sources for which "Delete" is selected at "Source Delete" cannot be selected.

**Dolby Headphone recording**

When REC OUT mode is set to "SOURCE", with the AVP-A1HDCI it is possible to output signals encoded in the Dolby Headphone mode from the recording output terminal and record them on a separate recorder.

**1** The Dolby Headphone play mode is set when headphones are connected to **<PHONES>** during playback in the **STANDARD (DOLBY/DTS Surround) mode**.

When this is done, signals encoded in the Dolby Headphone mode are automatically output from the recording output terminals (analog and digital) and can be recorded.

**2** Select the parameters and set the desired mode.

Start recording.

Refer to the "Dolby Headphone" (page 51).

**NOTE**

Do not disconnect the headphones during recording.

## Convenient Functions

### HDMI Control Function

When connecting the AVP-A1HDCI to a television or player compatible with the HDMI control function, the following operations are possible.

- Turn power ON/OFF (Synchronize with television)
- Switch to sound output equipment (TV and AVP-A1HDCI)
- Adjust volume
- Switch input source



When using these functions set as follows: GUI menu "Manual Setup" – "HDMI Setup" – "HDMI Control" (page 32).

#### NOTE

When using the HDMI control function, do not assign HDMI input to "TV/CBL" by setting "Source Select" – "(input source)" – "Assign" in the GUI menu.

### Connections

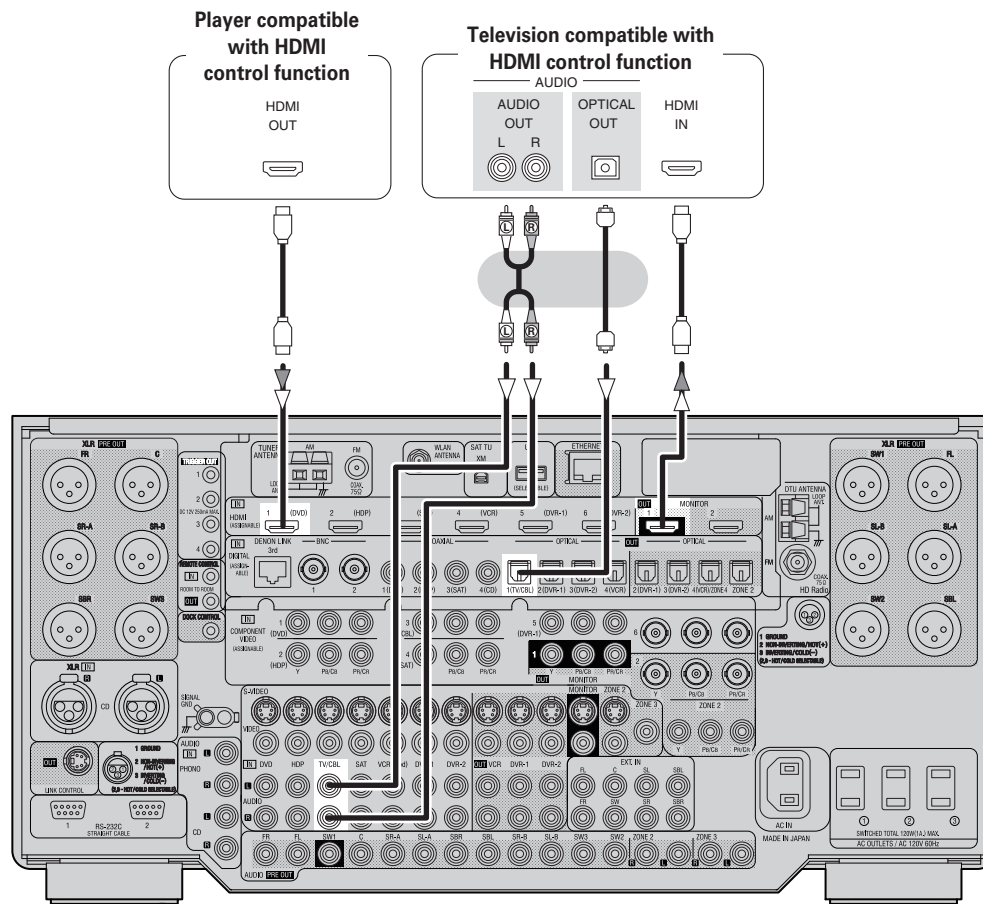

## Operations

**1** Connect the HDMI to the AVP-A1HDCI with equipment compatible with the HDMI control function.

**2** Put the power on for all the equipment connected to the HDMI.

**3** Check the settings for all the equipment connected to the HDMI and make HDMI available to them.

※ Please consult the operating instructions for the connected equipment to check the settings.

※ Operations 1 ~ 3 do not have to be repeated once started.

※ Carryout Operations 2 and 3 should any of the equipment be plugged out.

**4** Switch the television input to the HDMI connected to the AVP-A1HDCI.

**5** Switch the AVP-A1HDCI input to the HDMI input source and check if the picture from the player is ok.

**6** Put the television power on standby and check if the AVP-A1HDCI goes into standby.



If the AVP-A1HDCI does not work please check the following.

- Is the GUI menu "Manual Setup" – "HDMI Setup" – "HDMI Control" – "Control" (page 32) set to "ON"?
- Is the GUI menu "Manual Setup" – "HDMI Setup" – "HDMI Control" – "Control Monitor" (page 32) set for the monitor output connected to television?
- Is the GUI menu "Manual Setup" – "HDMI Setup" – "HDMI Control" – "Power Off Control" (page 32) set to "ON"?
- Is the control function used for the television HDMI properly set? (Check the television operating instructions for details.)
- Should any of the operations below be performed, the interlocking function may be reset, in which case, repeat Operation's 2 and 3.
  - GUI menu "Source Select" – "(input source)" – "Assign" – "HDMI" (page 48) setting has changed
  - There is a change to the connection between the equipment and the HDMI, or an increase in equipment.
  - Change of HDMI monitor output in AVP-A1HDCI setup.

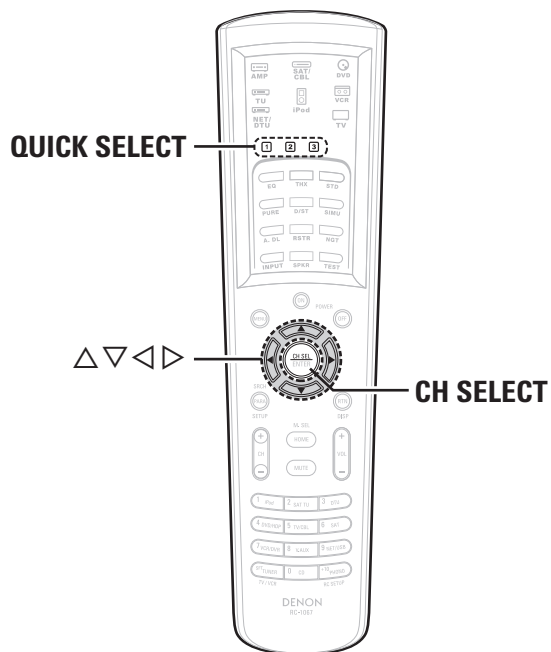
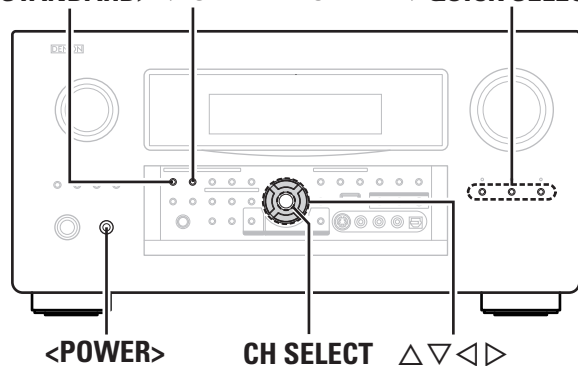

**<STANDARD> <HOME THX CINEMA> QUICK SELECT****About the button names in these explanations**

- < > : Buttons on the main unit  
 [ ] : Buttons on the remote control unit

**Button name only:**

Buttons on the main unit and remote control unit

**Channel Level**

You can adjust the channel level either according to the playback sources or to suit your taste, as described below.

- 1 Press CH SELECT.**
- 2 Use  $\Delta$   $\nabla$  or CH SELECT to select the speaker.**  
The speaker that can be set switches each time one of the buttons is pressed.
- 3 Use  $\triangleleft$   $\triangleright$  to adjust the volume.**

※ "OFF" can be set by pressing  $\triangleleft$  when the subwoofer's volume is set to -12dB.

**Fader Function**

This function lets you adjust (fade) the sound from all the front or rear speakers at once.

- 1 Press CH SELECT.**
- 2 Press  $\Delta$   $\nabla$  or CH SELECT to select "Fader".**
- 3 Use  $\triangleleft$   $\triangleright$  to adjust the volume of the speakers.**  
( $\triangleleft$ : front,  $\triangleright$ : rear)



- The fader function does not affect the subwoofer.
- The fader can be adjusted until the volume of the speaker adjusted to the lowest value is -12 dB.

**Quick Select Function**

With this function, the currently playing input source, input mode, surround mode, room EQ settings and volume can be stored in the memory.

- 1 Set the input source, input mode, surround mode, room EQ settings and volume to the conditions you want to store.**
- 2 Press and hold the desired QUICK SELECT.**  
Keep pressing the button until the quick select indicator lights.

**[Quick Select Defaults]**

|                       | Input Source | Volume |
|-----------------------|--------------|--------|
| <b>Quick Select 1</b> | DVD          | -40 dB |
| <b>Quick Select 2</b> | TV/CBL       | -40 dB |
| <b>Quick Select 3</b> | VCR          | -40 dB |



- To call out the settings, press **QUICK SELECT** at which the desired settings were stored.
- The Quick Select name can be changed (☞ page 42).

**NOTE**

Input sources stored with the quick select function cannot be selected if they have been deleted at GUI menu "Manual Setup" - "Option Setup" - "Source Delete" (☞ page 41). In this case, store them again.

**Personal Memory Plus Function**

This function sets the settings (input mode, surround mode, HDMI output mode, Picture Adjust, Audio Delay etc.) last selected for the individual input sources.

When you switch to an input source, the settings are automatically set to the ones that were set the last time that input source was used.



The surround parameters, tone control, room EQ settings and the volumes of the different speakers are stored for the individual surround modes.



## Last Function Memory

This stores the settings as they were directly before the standby mode was set.

When the power is turned back on, the settings are restored to as they were directly before the standby mode was set.

## Backup Memory

The various settings are backed up for about 1 week, even if the power is turned off or the power cord is disconnected.

## Resetting the Microprocessor

Perform this procedure if the display is abnormal or if operations cannot be performed.

All settings are reset when the microcomputer is reset.

- 1** Turn off the power using **<POWER>**.
- 2** Press **<POWER>** while simultaneously pressing **<STANDARD>** and **<HOME THX CINEMA>**.
- 3** Once the display starts flashing at intervals of about 1 second, release the two buttons.



If in step 3 the display does not flash at intervals of about 1 second, start over from step 1.

## Remote Control Unit Operations

### Main Remote Control Unit

- On the main remote control unit, the display switches according to the device being operated and the mode.
- In modes other than iPod, the mode switches between "DEV1" and "DEV2" each time the [MODE SELECTOR] is pressed.
- In the AMP, TUNER, NET/DTU and iPod modes, when the remote ID is set, the AVP-A1HDCI can be used independently even in an environment containing multiple DENON amplifiers.

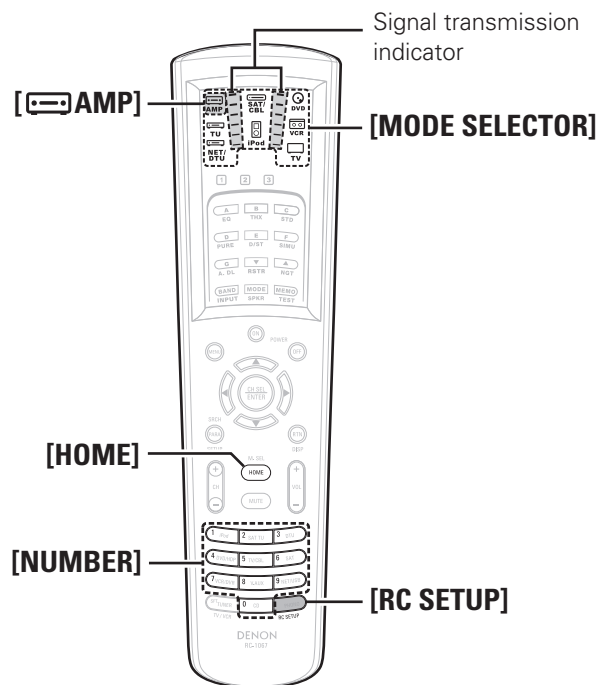

Depending on the model and year of manufacture of your equipment, some buttons may not operate.

#### NOTE

The device mode ("DEV1" or "DEV2") cannot be changed while the setting is being made.

### Operating DENON Audio Components

#### 1 Press [MODE SELECTOR] for the component to be operated.

The indicator for the component to be operated flashes.

|   |  |
|---|--|
| : AMP / ZONE2 / ZONE3 / ZONE4 / SYSTEM CALL | : iPod   |
| : TUNER (FM/AM) / XM                        | : DVD player (recorder) / CD player (recorder) |
| : NETWORK/USB / DIGITAL TUNER (HD Radio)    | : VCR / TAPE                                   |
| : Satellite Receiver / Cable TV             | : TV   |

※ The mode switches each time [AMP] is pressed.

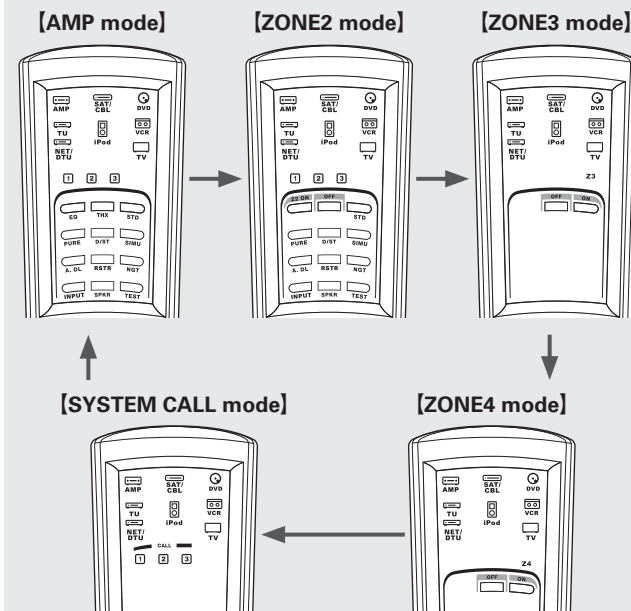

#### 2 Operate the component.

※ For details, refer to the component's operating instructions.



[HOME] is used to return to the AMP mode (AMP, ZONE2, ZONE3, ZONE4 or SYSTEM CALL) when in any mode other than AMP.

### Presetting

The included main remote control unit can be preset to operate devices of various brands.

#### 1 Press [MODE SELECTOR] for the device you want to preset.

#### 2 Press and hold in [RC SETUP] for at least 3 seconds.

The signal transmission indicator flashes twice.

#### 3 Press [NUMBER] and input the 5-digit number of the brand of the component to be preset. The numbers are shown in the Preset Code Table (End of this manual).

When the code is registered, the signal transmission indicator flashes twice.

When the preset code is transmitted, the mode indicator for the component to which that code belongs flashes.

※ The input mode is canceled if no button is operated for 10 seconds.



Some brands have more than one preset code. If the component does not operate, try inputting a different code.

### Operating Preset Components

#### 1 Press [MODE SELECTOR] for the component to be operated.

The mode indicator of the device to be operated flashes.

#### 2 Operate the component.

※ For details, refer to the component's operating instructions.

## Functions of Buttons by Component

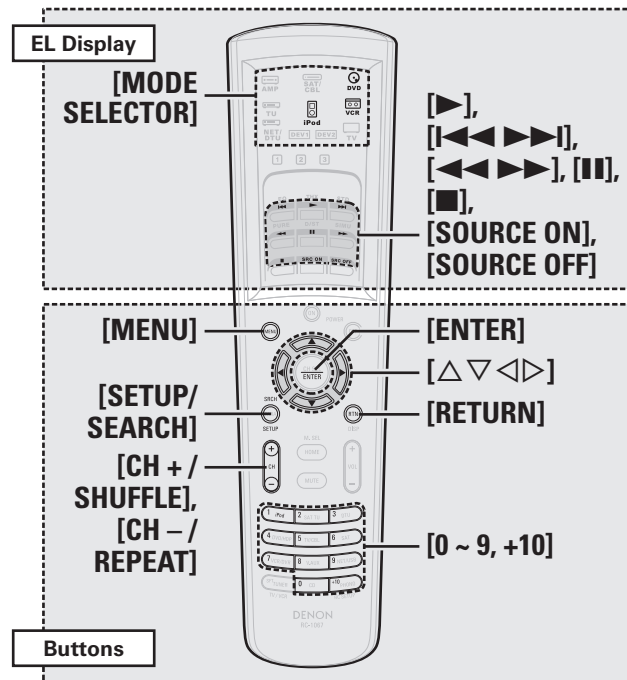

| EL Display      |  |  |  |  |  |  |  |
|-----------------|--|--|--|--|--|--|--|
| MODE SELECTOR   | DVD  |  |  |  | VCR  |  | iPod   |
| Device Mode     | DEV1   |  | DEV2   |  | DEV1   | DEV2   | DEV1   |
| Device operated | DVD<br>(Default setting)                         | DVD Recorder                                     | CD<br>(Default setting)                          | CD Recorder                                      | VCR  | TAPE   | iPod   |
| ▶               | Playback   | Playback   | Playback   | Playback   | Playback   | Playback   | Playback/Pause   |
| ◀▶▶▶            | Auto search<br>(cue)                             | Auto search<br>(cue)                             | Auto search<br>(cue)                             | Auto search<br>(cue)                             | Auto search<br>(cue)                             | Auto search<br>(cue)                             | Auto search<br>(cue)   |
| ◀▶▶             | Manual search<br>(fast-reverse/<br>fast-forward) | Manual search<br>(fast-reverse/<br>fast-forward) | Manual search<br>(fast-reverse/<br>fast-forward) | Manual search<br>(fast-reverse/<br>fast-forward) | Manual search<br>(fast-reverse/<br>fast-forward) | Manual search<br>(fast-reverse/<br>fast-forward) | Manual search<br>(fast-reverse/<br>fast-forward)                                 |
| ⏸               | Pause  | Pause  | Pause  | Pause  | Pause  | Pause  | –  |
| ■               | Stop   | Stop   | Stop   | Stop   | Stop   | Stop   | Stop   |
| SOURCE ON       | Power on   | Power on   | –  | –  | Power on   | –  | –  |
| SOURCE OFF      | Power off  | Power off  | –  | –  | Power off  | –  | –  |
| Buttons         |  |  |  |  |  |  |  |
| MENU            | Menu/guide                                       | Menu/guide                                       | –  | –  | Menu/guide                                       | –  | Menu   |
| △ ▽ ◀ ▶         | Cursor   | Cursor   | –  | –  | Cursor   | –  | Cursor   |
| ENTER           | Enter setting                                    | Enter setting                                    | –  | –  | Enter setting                                    | –  | Enter  |
| SETUP/SEARCH    | Set up   | Set up   | –  | –  | Set up   | –  | Page forward<br>screen / Browse/<br>Remote mode<br>switching (Press<br>and hold) |
| RETURN          | Return   | Return   | –  | –  | Cancel   | –  | Return   |
| CH + / SHUFFLE  | –  | –  | –  | –  | Switch channels                                  | –  | 1-track/album<br>shuffle play  |
| CH - / REPEAT   | –  | –  | –  | –  | Switch channels                                  | –  | 1-track/all-track<br>repeat play   |
| 0 ~ 9, +10      | Select track                                     | Select track                                     | Select track                                     | Select track                                     | –  | –  | –  |
| Special Remarks | ①, ②   |  | ①  |  | ①  | ①  | –  |

### [Special Remarks]

- ① Only one component can be preset for each mode. If a new code is preset, the previous code is automatically cleared.
- ② The names of the functions for the DVD remote control buttons differ from brand to brand. Check beforehand.

### NOTE

- Preset a DVD player or DVD recorder for the "DVD" ([DEV1]) mode. Preset a CD player or CD recorder for the "DVD" ([DEV2]) mode.
- Preset a VCR for the "VCR" ([DEV1]) mode. Preset a tape deck for the "VCR" ([DEV2]) mode.



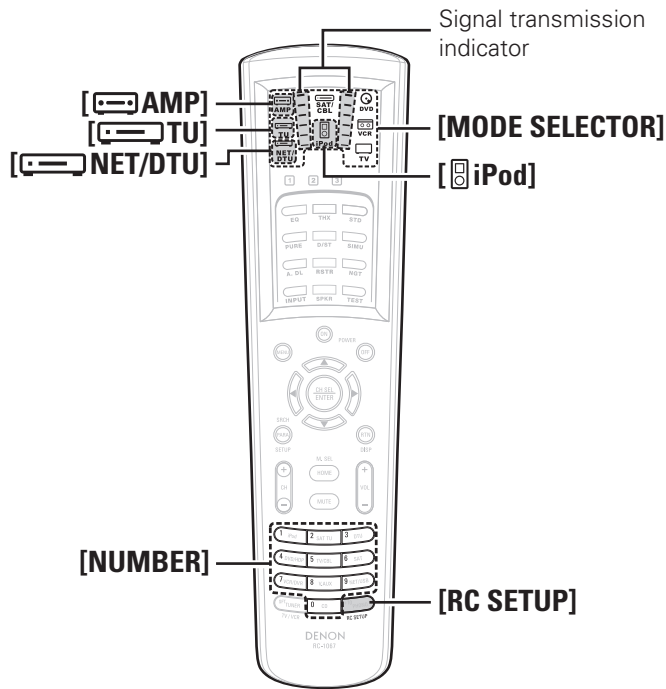

### Setting the Remote ID

When using multiple DENON AV receivers in the same room, make this setting so that only the desired AV receiver operates.

- 1** Press **[AMP]** to set the main remote control unit to the AMP mode.
- 2** Press and hold in **[RC SETUP]** for at least 3 seconds. The signal transmission indicator flashes twice.
- 3** Refer to the table at the right, and use **[NUMBER]** to input the 5-digit number corresponding to the remote ID to be changed. The signal transmission indicator flashes twice.
- 4** Press **[TU]**, **[iPod]** or **[NET/DTU]** to select the mode to be set.
- 5** Repeat steps 2 to 4 to set the remote IDs for all modes.

| MODE SELECTOR | AMP (MAIN) | TUNER                           |                       | iPod  | NET/DTU                      |                             |
|---------------|------------|---------------------------------|-----------------------|-------|------------------------------|-----------------------------|
|               |            | <b>[DEV1]</b><br>(Analog TUNER) | <b>[DEV2]</b><br>(XM) |       | <b>[DEV1]</b><br>(Net Audio) | <b>[DEV2]</b><br>(HD Radio) |
| Remote ID     |            |                                 |                       |       |                              |                             |
| 1 (Default)   | 81001      | 52863                           | 52864                 | 72815 | 62865                        | 62840                       |
| 2             | 82001      | 52795                           | 52812                 | 72816 | 62837                        | 62841                       |
| 3             | 83001      | 52800                           | 52813                 | 72817 | 62838                        | 62842                       |
| 4             | 84001      | 52805                           | 52814                 | 72818 | 62839                        | 62843                       |

#### NOTE

- When changing a setting, be sure to set the same remote ID as the AVP-A1HDCI's (page 43).
- When changing the AMP mode's remote ID, also change the "TUNER", "iPod" and "NET/DTU" remote ID at the same time.
- Set the remote ID of an analog tuner for "TUNER" (**[DEV1]**), the XM remote ID for "**[DEV2]**".

### Learning Function

If your AV devices are of a brand other than DENON or if they cannot be operated with the preset memory function, their remote control signals can be transferred to stored in the AVP-A1HDCI's main remote control unit.

- 1** Press **[MODE SELECTOR]** for the device you want to set.
- 2** Press and hold in **[RC SETUP]** for at least 3 seconds. The signal transmission indicator flashes twice.
- 3** Press **[9]**, **[7]** and **[5]**, in that order. The signal transmission indicator flashes twice and the learning mode is set.
- 4** Press the button to be set. The main remote control unit's display turns off.
  - ※ If a button that cannot be learned is pressed, the signal transmission indicator lights but the signal is not learned.

### 5 Point the main remote control units directly at each other and press and hold the button on the other device's remote control unit that you want to learn.

Once learning is completed normally, the display lights and the signal transmission indicator flashes twice.

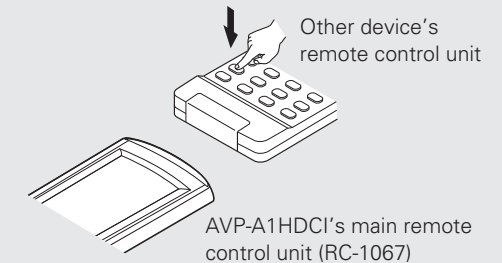

- ※ If you want to learn other buttons, repeat steps 4 and 5.
- ※ The mode can be switched by pressing **[MODE SELECTOR]**.
- ※ The signal transmission indicator lights once for a long time if learning was not possible

### 6 Press and hold in **[RC SETUP]** for at least 3 seconds.

The signal transmission indicator flashes twice and the setting is completed.



- With some remote control units, the signals cannot be learned or the device will not operate properly even when the signals have been learned. In this case, use the device's own remote control unit.
- Learned buttons have priority over the preset memory. If you no longer need the learned setting, reset the learning function (page 82).

#### NOTE

- **[HOME]** cannot be learned.
- Do not learn any remote control signals at **[RC SETUP]**.
- The AMP, ZONE2, ZONE3, ZONE4 and SYSTEM CALL modes cannot be learned.

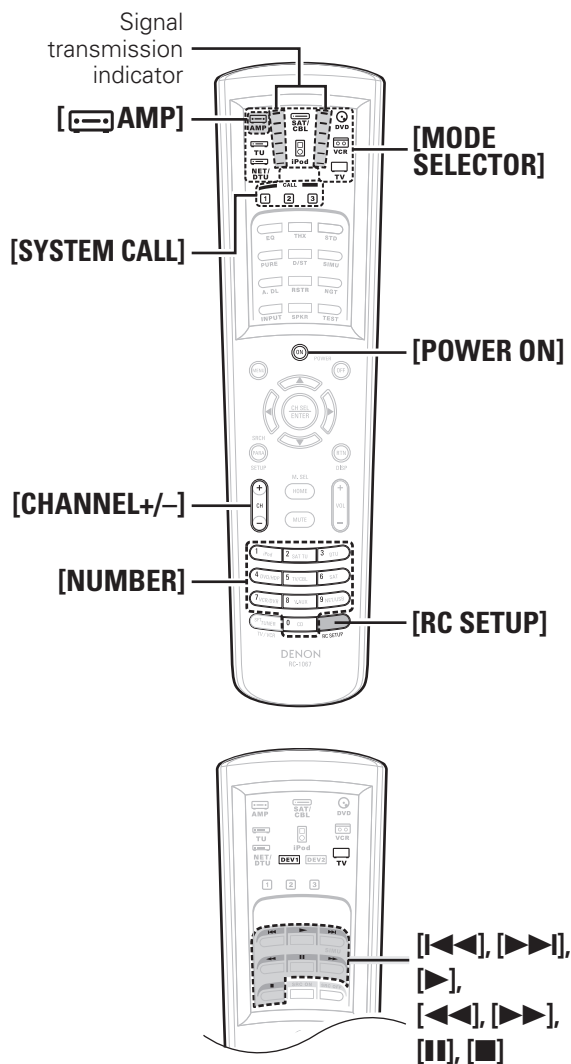

## System Call Function

This function lets you register a series of operations at a single button.

For example, the amplifier can be turned on, the input source selected, the monitor's power turned on and the play mode set all by pressing a single button.

Up to 32 signals each can be registered at **[SYSTEM CALL]** (1, 2 or 3).

## Registering

**1** Press **[MODE SELECTOR]** for the device you want to register.

**2** Press and hold in **[RC SETUP]** for at least 3 seconds. The signal transmission indicator flashes twice.

**3** Press **[9], [7]** and **[8]**, in that order. The signal transmission indicator flashes twice and the system call registration mode is set.

**4** Press **[SYSTEM CALL]** (1, 2 or 3) at which you want to register the signals.

**5** Press the buttons you want to register in the same sequence as the operations you want to perform.

The signal transmission indicator lights when a button is pressed.

**Example** : Press **[POWER ON]**.

↓  
Press **[MODE SELECTOR]** - **[DVD]**.

↓  
Press **[▶]**.

※ The mode can be switched by pressing **[MODE SELECTOR]**.

※ Perform the registration procedure for all the buttons you want to register.

**6** Press and hold in **[RC SETUP]** for at least 3 seconds. The signal transmission indicator flashes twice and the setting is completed.

## Calling out

**1** Press **[AMP]**, to select "SYSTEM CALL".

**2** Press **[SYSTEM CALL]** (1, 2 or 3) at which the signals were registered.

The registered signals are transmitted in the registered sequence.

## Punch Through Function

CD, DVD or VCR mode buttons can be stored at unused TV or SAT/CBL mode buttons.

For example, when DVD mode buttons are assigned to the TV mode, the DVD mode operations can be performed while in the TV mode.

**1** Press **[MODE SELECTOR]** for the device you want to punch through (CD, DVD or VCR).

**2** Press and hold in **[RC SETUP]** for at least 3 seconds. The signal transmission indicator flashes twice.

**3** Press **[9], [8]** and **[4]**, in that order. The signal transmission indicator flashes twice and the punch through setting mode is set.

**4** Press **[MODE SELECTOR]** for the device you want to punch through (CD, DVD or VCR).

**5** Press the button you want to punch through (**[▶]**, **[■]**, **[◀◀]**, **[▶▶]**, **[◀◀▶▶]** or **[||]**).

**6** Press **[MODE SELECTOR]** for the equipment (TV or SAT/CBL) you want to set to punch-through.

**7** Press and hold in **[RC SETUP]** for at least 3 seconds. The signal transmission indicator flashes twice and the setting is completed.



## Setting the Time the Backlight Stays Lit

- 1 Press and hold in [RC SETUP] for at least 3 seconds.**  
The signal transmission indicator flashes twice.
- 2 Press [9], [7] and [3], in that order.**  
The signal transmission indicator flashes twice and the backlight on time setting mode is set.
- 3 Set the light on time.**  
The signal transmission indicator flashes twice.  
**[Settable times] :** [1] : 5 sec.  
[2] : 10 sec. (Default)  
[3] : 15 sec.  
[4] : 20 sec.  
[5] : 25 sec.

## Adjusting the Backlight's Brightness

The display's brightness can be adjusted in 5 steps.  
(Default: Step 3)

- 1 Press and hold in [RC SETUP] for at least 3 seconds.**  
The signal transmission indicator flashes twice.
- 2 Press [CHANNEL +] or [CHANNEL -].**  
The display gets one step brighter when [+ ] is pressed.  
The display gets one step darker when [- ] is pressed.
- 3 Press [RC SETUP] to complete the setting.**

## Resetting the Main Remote Control Unit

### Learning Function

#### [Resetting button by button]

- 1 Press [MODE SELECTOR] for the device you want to reset.**
- 2 Press and hold in [RC SETUP] for at least 3 seconds.**  
The signal transmission indicator flashes twice.
- 3 Press [9], [7] and [6], in that order.**  
The signal transmission indicator flashes twice.
- 4 Press the button you want to reset twice.**  
The signal transmission indicator flashes twice.

#### [Resetting by device mode]

- 1 Press [MODE SELECTOR] for the device you want to reset.**
- 2 Press and hold in [RC SETUP] for at least 3 seconds.**  
The signal transmission indicator flashes twice.
- 3 Press [9], [7] and [6], in that order.**  
The signal transmission indicator flashes twice.
- 4 Press [MODE SELECTOR] for the device you want to reset twice.**  
The signal transmission indicator flashes twice.

### System call function

- 1 Press and hold in [RC SETUP] for at least 3 seconds.**  
The signal transmission indicator flashes twice.
- 2 Press [9], [7] and [8], in that order.**  
The signal transmission indicator flashes twice.
- 3 Press [SYSTEM CALL] (1, 2 or 3) you want to reset.**
- 4 Press and hold in [RC SETUP] for at least 3 seconds.**  
The signal transmission indicator flashes twice.

### Punch-through function

- 1 Press [MODE SELECTOR] for the device you want to reset (TV or SAT/CBL).**
- 2 Press and hold in [RC SETUP] for at least 3 seconds.**  
The signal transmission indicator flashes twice.
- 3 Press [9], [8] and [4], in that order.**  
The signal transmission indicator flashes twice.
- 4 Press and hold in [RC SETUP] for at least 3 seconds.**  
The signal transmission indicator flashes twice.

### All settings

- 1 Press and hold in [RC SETUP] for at least 3 seconds.**  
The signal transmission indicator flashes twice.
- 2 Press [9], [8] and [1], in that order.**  
The signal transmission indicator flashes 4 times.  
All the settings are restored to their defaults.

## Sub Remote Control Unit Operations

- The sub remote control unit is equipped with frequently used buttons, so it can be used for simple remote control unit operations.
- The sub remote control unit can also be used for multi-zone, so you can use it to control the AVP-A1HDCI from other rooms.
- The operations listed below can be performed with the sub remote control unit.
  - Switching the input source
  - Adjusting the volume
  - Tuner (AM/FM), XM, HD Radio and iPod operations
  - NET/USB direct play
  - GUI menu and ZONE2 on-screen display operations
  - Zone power on/off
- It is not possible to operate devices other than the amplifier.

## Functions of Buttons by Component

| Device operated                           | DVD, HDP, TV / CBL, DVR-1, DVR-2, VCR, V.AUX, SAT, CD, PHONO |    |    |    | TUNER (AM/FM)                         |    |    |    | DTU (HD Radio)                        |    |    |    |
|---|--|----|----|----|---------------------------------------|----|----|----|---------------------------------------|----|----|----|
|   | M  | Z2 | Z3 | Z4 | M                                     | Z2 | Z3 | Z4 | M                                     | Z2 | Z3 | Z4 |
| <b>Zone selection</b>                     |  |    |    |    |                                       |    |    |    |                                       |    |    |    |
| <b>ZONE SELECT</b>                        | Zone operation mode selection                                |    |    |    | Zone operation mode selection         |    |    |    | Zone operation mode selection         |    |    |    |
| <b>ZONE OFF</b>                           | Power turned off (※1)  |    |    |    | Power turned off (※1)                 |    |    |    | Power turned off (※1)                 |    |    |    |
| <b>ZONE ON</b>                            | Power turned on (※1)   |    |    |    | Power turned on (※1)                  |    |    |    | Power turned on (※1)                  |    |    |    |
| <b>SOURCE SELECT</b>                      | Input source selection (※2)                                  |    |    |    | Input source selection                |    |    |    | Input source selection                |    |    |    |
| <b>CHANNEL +/-</b>                        | -  |    |    |    | Preset channel selection              |    |    |    | Preset channel selection              |    |    |    |
| <b>SHIFT</b>                              | -  |    |    |    | Preset channel memory block selection |    |    |    | Preset channel memory block selection |    |    |    |
| <b>VOLUME +/-</b>                         | Adjustment of volume (※1)                                    |    |    |    | Adjustment of volume (※1)             |    |    |    | Adjustment of volume (※1)             |    |    |    |
| <b>MUTE</b>                               | Muting (※1)  |    |    |    | Muting (※1)                           |    |    |    | Muting (※1)                           |    |    |    |
| <b>MENU</b>                               | Selected zone menu   |    |    |    | Selected zone menu                    |    |    |    | Selected zone menu                    |    |    |    |
| <b>Δ ▽ ◀ ▶</b>                            | -  |    |    |    | -                                     |    |    |    | Multicast switching (Δ ▽)             |    |    |    |
| <b>SEARCH</b>                             | -  |    |    |    | RDS search                            |    |    |    | Multicast switching                   |    |    |    |
| <b>I◀▶▶▶I, TUNING ▲ ▼</b>                 | -  |    |    |    | Tuning                                |    |    |    | Tuning                                |    |    |    |
| <b>USB</b>                                | ※3   |    |    |    | ※3                                    |    |    |    | ※3                                    |    |    |    |
| <b>ALL MUSIC *</b><br>(Media server only) | ※4   |    |    |    | ※4                                    |    |    |    | ※4                                    |    |    |    |
| <b>FAVORITES *</b>                        | ※5   |    |    |    | ※5                                    |    |    |    | ※5                                    |    |    |    |

※1: Affects the currently selected zone.

※2: In ZONE4, it is not possible to select "XM", "HD Radio", or sources with no digital input signals ("TUNER", "PHONO", "iPod", etc.). Network audio signals (Internet radio, media server, USB) can be played as long as they are not copyright-protected.

※3: The input source switches to "NET/USB" and the files on the USB memory device are played.

※4: The input source switches to "NET/USB" and the files in "All Music" on the media server are played.

※5: The input source switches to "NET/USB" and the files in "Favorites" are played.

\*: Whether "All Music" or "Favorites" is selected depends on the "Direct Play" setting (page 49).

| DIRECT PLAY button   |  |
|--|--|
| • Playback is possible in the mode selected at GUI menu "Source Select" – "NET/USB" – "Playback Mode" – "Direct Play". |  |
| <b>FAVORITES:</b> Playback starts from the first track registered in the favorites.                                    |  |
| <b>ALL MUSIC:</b> Playback starts from the first track registered in the "All Music" folder.                           |  |
| • When [USB] is pressed, playback starts from the first track on the USB memory device.                                |  |
| <b>NOTE</b>  |  |
| When the media server is stopped or restarted, it may no longer be possible to play tracks stored in the favorites.    |  |

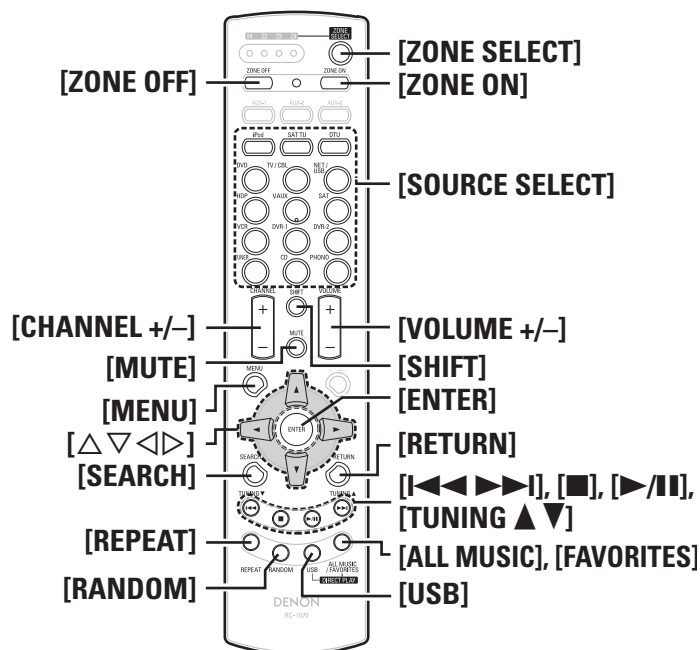

| Device operated                           | SAT TU<br>(XM)                        |    |    |    | NET / USB  |    |    |    | iPod  |    |    |    |
|---|---------------------------------------|----|----|----|--|----|----|----|---|----|----|----|
|   | M                                     | Z2 | Z3 | Z4 | M  | Z2 | Z3 | Z4 | M   | Z2 | Z3 | Z4 |
| <b>ZONE SELECT</b>                        | Zone operation mode selection         |    |    |    | Zone operation mode selection                      |    |    |    | Zone operation mode selection                                       |    |    |    |
| <b>ZONE OFF</b>                           | Power turned off (※1)                 |    |    |    | Power turned off (※1)                              |    |    |    | Power turned off (※1)   |    |    |    |
| <b>ZONE ON</b>                            | Power turned on (※1)                  |    |    |    | Power turned on (※1)                               |    |    |    | Power turned on (※1)  |    |    |    |
| <b>SOURCE SELECT</b>                      | Input source selection                |    | -  |    | Input source selection (※2)                        |    |    |    | Input source selection  |    | -  |    |
| <b>CHANNEL + / -</b>                      | Preset channel selection              |    | -  |    | Preset channel selection                           |    |    |    | -   |    |    |    |
| <b>SHIFT</b>                              | Preset channel memory block selection |    | -  |    | -  |    |    |    | -   |    |    |    |
| <b>VOLUME + / -</b>                       | Adjustment of volume (※1)             |    | -  |    | Adjustment of volume (※1)                          |    | -  |    | Adjustment of volume (※1)   |    | -  |    |
| <b>MUTE</b>                               | Muting (※1)                           |    | -  |    | Muting (※1)  |    | -  |    | Muting (※1)   |    | -  |    |
| <b>MENU</b>                               | Selected zone menu                    |    | -  |    | Selected zone menu                                 |    | -  |    | Selected zone menu  |    | -  |    |
| △ ▽ ◀ ▶                                   | Category search                       |    | -  |    | File operations                                    |    | -  |    | File operations   |    | -  |    |
| <b>ENTER</b>                              | -                                     |    |    |    | File operations                                    |    | -  |    | File operations   |    | -  |    |
| <b>SEARCH</b>                             | Direct access of channel              |    |    |    | Page forward screen / Character search             |    | -  |    | Page forward screen / Browse/Remote mode switching (press and hold) |    | -  |    |
| <b>RETURN</b>                             | -                                     |    |    |    | File operations                                    |    | -  |    | File operations   |    | -  |    |
| <b>I◀◀ ▶▶I,<br/>TUNING ▲ ▼</b>            | Channel selection                     |    | -  |    | Track search                                       |    |    |    | Track search  |    | -  |    |
| ■   | -                                     |    |    |    | Stop   |    |    |    | Stop  |    | -  |    |
| ▶/  | -                                     |    |    |    | Play/pause   |    |    |    | Play/pause  |    | -  |    |
| <b>REPEAT</b>                             | -                                     |    |    |    | 1-track/all-track repeat play (USB / Media server) |    |    |    | 1-track/all-track repeat play                                       |    | -  |    |
| <b>RANDOM</b>                             | -                                     |    |    |    | Random play (USB / Media server)                   |    |    |    | Song/album shuffle play   |    | -  |    |
| <b>USB</b>                                | ※3                                    |    | -  |    | ※3   |    |    |    | ※3  |    | -  |    |
| <b>ALL MUSIC *</b><br>(Media server only) | ※4                                    |    | -  |    | ※4   |    |    |    | ※4  |    | -  |    |
| <b>FAVORITES *</b>                        | ※5                                    |    | -  |    | ※5   |    |    |    | ※5  |    | -  |    |

※1: Affects the currently selected zone.

※2: In ZONE4, it is not possible to select "XM", "HD Radio", or sources with no digital input signals ("TUNER", "PHONO", "iPod", etc.).

Network audio signals (Internet radio, media server, USB) can be played as long as they are not copyright-protected.

※3: The input source switches to "NET/USB" and the files on the USB memory device are played.

※4: The input source switches to "NET/USB" and the files in "All Music" on the media server are played.

※5: The input source switches to "NET/USB" and the files in "Favorites" are played.

\*: Whether "All Music" or "Favorites" is selected depends on the "Direct Play" setting (page 49).

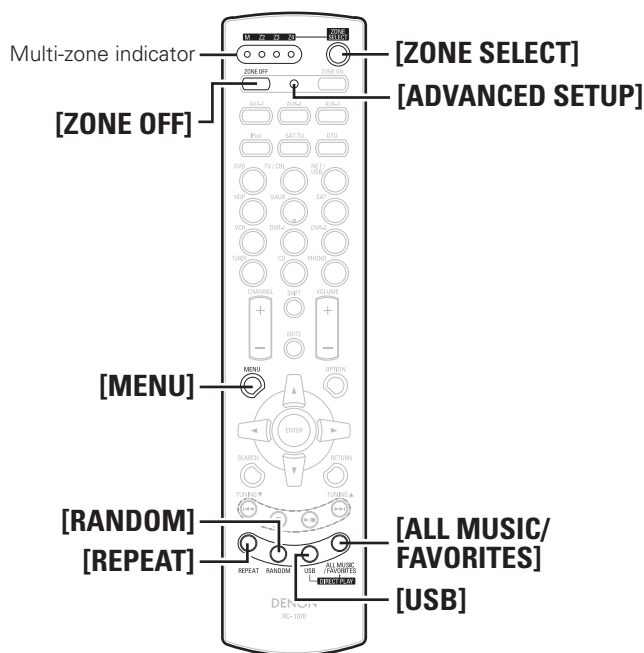

## Switching Zones

Use this procedure to select the zone to be operated by the sub remote control unit.

- 1 Press **[ZONE SELECT]**.  
The currently selected multi-zone indicator lights.
- 2 While the multi-zone indicator is light, press **[ZONE SELECT]** to select the zone to be operated.  
The currently selected multi-zone indicator lights.

## Setting the Zone for Which the Sub Remote Control Unit is Used (ZONE SELECT LOCK Mode)

We recommend always using the sub remote control unit for the same room. When this is done, the unit can be set so that the zone does not switch when buttons are operated.

- 1 Use the tip of a pen to press **[ADVANCED SETUP]**.  
All the multi-zone indicators light.
- 2 Select the multi-zone to be set.  
The selected multi-zone indicator lights.
  - ① To set to "MAIN ZONE": Press **[REPEAT]**.
  - ② To set to "ZONE2": Press **[RANDOM]**.
  - ③ To set to "ZONE3": Press **[USB]**.
  - ④ To set to "ZONE4": Press **[ALL MUSIC/FAVORITES]**.

- 3 Use the tip of a pen to press **[ADVANCED SETUP]**.  
The multi-zone indicator turns off.

### To Cancel

- 1 Use the tip of a pen to press **[ADVANCED SETUP]**.  
The currently selected multi-zone indicator lights.
- 2 Press **[ZONE SELECT]**.  
All the multi-zone indicators light.
- 3 Use the tip of a pen to press **[ADVANCED SETUP]**.  
The multi-zone indicator turns off.

## Setting the Remote ID

When using multiple DENON AV receivers in the same room, make this setting so that no AV receiver other than the desired one operates.

- 1 While pressing **[MENU]**, press **[ADVANCED SETUP]** with the tip of a pen.  
The multi-zone indicator corresponding to the currently selected remote ID flashes.
- 2 Select the remote ID to be set.
  - ① To set to 1: Press **[REPEAT]**.  
The "M" indicator flashes.
  - ② To set to 2: Press **[RANDOM]**.  
The "Z2" indicator flashes.
  - ③ To set to 3: Press **[USB]**.  
The "Z3" indicator flashes.
  - ④ To set to 4: Press **[ALL MUSIC/FAVORITES]**.  
The "Z4" indicator flashes.
- 3 While pressing **[MENU]**, press **[ADVANCED SETUP]** with the tip of a pen.  
The multi-zone indicator turns off.

### NOTE

When changing a setting, be sure to set the same remote ID as the AVP-A1HDCI's (page 43).

## Resetting the Settings

- While pressing **[ZONE OFF]**, press **[ADVANCED SETUP]** with the tip of a pen.  
All the multi-zone indicators flash 4 times, then all the settings are restored to their defaults.

# Multi-Zone Connections and Operations

## Multi-Zone Connections

- For ZONE2, it is necessary to set in sequence with the signal connected to either the power amplifier or bit stream amps. The amp should be the power amplifier in the case of ZONE3, and the bit-stream for ZONE4.
- If the signal inputted to ZONE2 is analog, change to PCM(2-channel) signal, and output it from ZONE2 optical output connectors.

|       | Connectors for audio output | Audio signals | Connectors for video output   |
|-------|-----------------------------|---------------|---|
| ZONE2 | ZONE2 PRE OUT               | Stereo        | ZONE2 VIDEO OUT,<br>ZONE2 S-VIDEO OUT,<br>ZONE2 COMPONENT VIDEO OUT |
|       | ZONE2 OPTICAL OUT           | Bit-stream    |   |
| ZONE3 | ZONE3 PRE OUT               | Stereo        | ZONE3 VIDEO OUT   |
| ZONE4 | ZONE4 OPTICAL4 OUT          | Bit-stream    | -   |

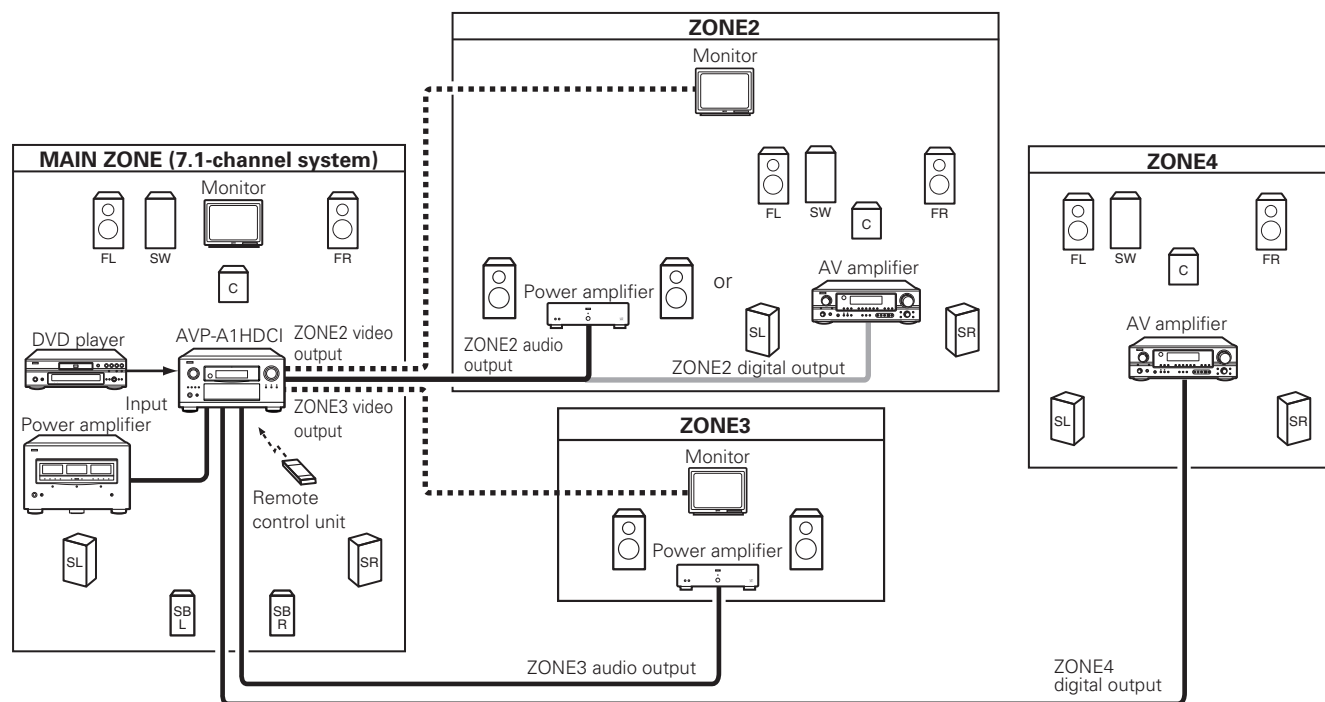

..... : Video cable  
 ————— : Audio cable



- When only using one speaker for ZONE2 or ZONE3, set to "Mono". In this case, the ZONE2 (ZONE3) monaural output is output from the ZONE2 (ZONE3) pre-out L and R connectors, so connect as desired.
- Separate power amplifiers are needed for ZONE2 and ZONE3.

## SOURCE SELECT &lt;ZONE2/3/4 / REC SELECT&gt; VOLUME

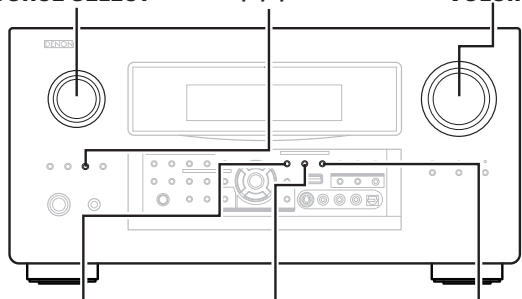

&lt;ZONE2 ON/OFF&gt; &lt;ZONE3 ON/OFF&gt; &lt;ZONE4 ON/OFF&gt;

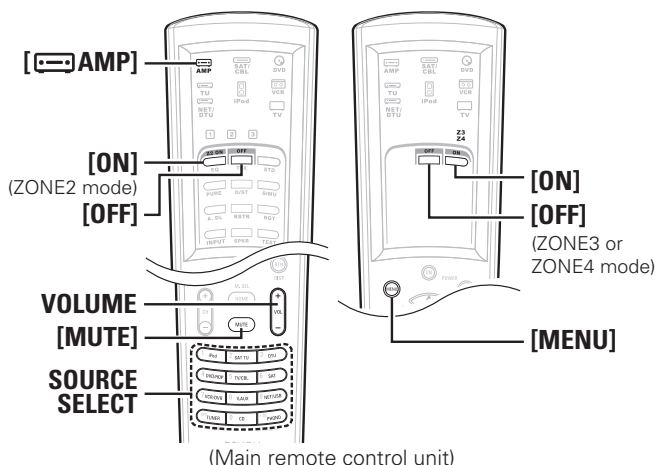

(Main remote control unit)

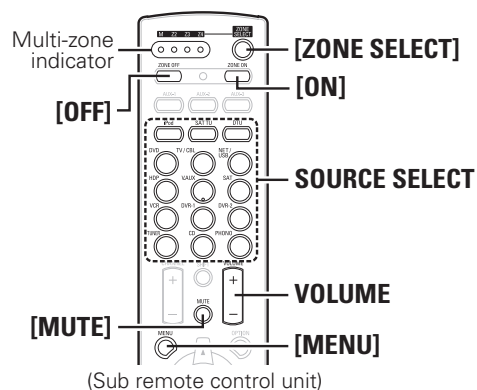

(Sub remote control unit)

## Multi-Zone Operations

## Turning the Power On and Off

**[Operation on the main unit]**

Press <ZONE2 ON/OFF>, <ZONE3 ON/OFF> or <ZONE4 ON/OFF> for the zone to be operated.

When the power turns on, the multi-zone indicator lights on the display.

**[Operation on the remote control unit]**

In the zone mode you want to operate, press [ON] or [OFF].

## Selecting the Input Source

**[Operation on the main unit]**

- 1 Press <ZONE2/3/4 / REC SELECT> and select the zone to be adjusted.
- 2 Turn <SOURCE SELECT>.

**[Operation on the remote control unit]**

In the zone mode you want to operate, press [SOURCE SELECT].

## Adjusting the Volume

**[Operation on the main unit]**

- 1 Press <ZONE2/3/4 / REC SELECT> and select the zone to be adjusted.
- 2 Turn <VOLUME> to adjust.

**[Operation on the remote control unit]**

In the zone mode whose volume you want to adjust, press [VOLUME].

[Variable range] --- -70dB ~ -40dB ~ 18dB



- The volume can be adjusted when GUI menu "Manual Setup" – "Zone Setup" – "(select the zone)" – "Volume Level" is set to "Variable". The volume can be increased up to the value set at GUI menu "Manual Setup" – "Zone Setup" – "(select the zone)" – "Volume Limit" (page 39).
- The volume for ZONE2 and ZONE3 can be adjusted with the remote control unit.

## Turning off the Sound Temporarily

In the zone mode for which you want to mute the sound, press [MUTE].

The sound is reduced to the level set at GUI menu "Manual Setup" – "Zone Setup" – "(select the zone)" – "Mute Level" (page 39).

To cancel, either adjust the volume or press [MUTE] again.

The setting is canceled when the zone's power is turned off.



- The source selected for ZONE3 is also output from the recording output connectors.
- When the [MENU] is selected, it is possible to carryout "Zone Setup" looking at the on-screen display in ZONE2. Also, when the "OSD" is set as "ZONE2/ZONE3", the on-screen display comes on the ZONE2 monitor when ZONE3 has been operated so it is possible to operate it looking at this.

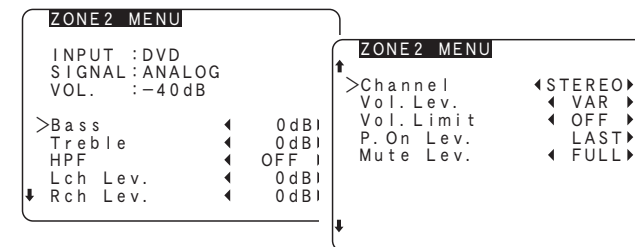

## NOTE

- The digital signal from the digital input connectors (OPTICAL/COAXIAL) are output to the analog audio connectors in ZONE2 and ZONE3 in the case of PCM (2-channel) signals only.
- Digital audio signals input from the DENON LINK or HDMI connectors cannot be played in multi-zone.
- "XM" or "HD Radio" cannot be selected with digital output (OPTICAL) in ZONE2. Copyright-protected Network audio signals (Internet radio, media server, USB, Rhapsody) cannot be output.
- In ZONE4, it is not possible to select "XM", "HD Radio", or sources with no digital input signals ("TUNER", "PHONO", "iPod", etc.). Network audio signals (Internet radio, media server, USB, Rhapsody) can be played as long as they are not copyright-protected.
- When certain digital signals are being input, noise may be output from the ZONE2 and ZONE3 audio output connectors.

## About the button names in these explanations

< > : Buttons on the main unit

[ ] : Buttons on the remote control unit

## Button name only:

Buttons on the main unit and remote control unit



# Other Information

## About Speaker Installation

### Surround back speakers

The THX Surround EX format adds new “Surround Back” (SB) channels to the conventional 5.1 channel system. This makes it easy to achieve sound positioned directly behind the listener, something that was previously difficult with sources designed for conventional multi surround speakers. In addition, the acoustic image extending between the sides and the rear is narrowed, thus greatly improving the expression of the surround signals for sounds moving from the sides to the back and from the front to the point directly behind the listening position.

Change of positioning and acoustic image with 5.1-channel systems

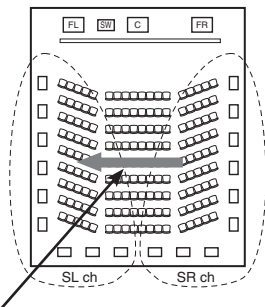

Movement of acoustic image from SR to SL

Change of positioning and acoustic image with 6.1-channel systems

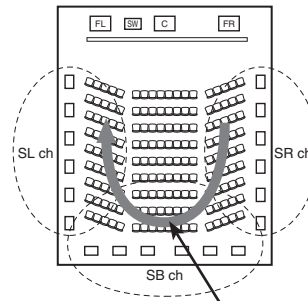

Movement of acoustic image from SR to SB to SL

In addition to sources recorded in 6.1-channels, the surround effect of conventional 2- to 5.1-channel sources can also be enhanced.

Speaker(s) for one or two channels are required in order to achieve a THX Surround EX system with the AVP-A1HDCI. Adding these, however, allows you to achieve stronger surround effects not only with sources recorded in THX Surround EX, but also with conventional 2- to 5.1 channel sources. The WIDE SCREEN mode is a mode for achieving surround sound with up to 7.1 channels using surround back speakers, for sources recorded in conventional Dolby Surround as well as Dolby Digital 5.1 channel and DTS Surround 5.1 channel sources. Furthermore, all the DENON original surround modes (page 51 “DSP Simulation Playback”) are compatible with 7.1 channel playback, so you can enjoy 7.1 channel sound with any signal source.

### Number of surround back speakers

With THX Surround EX, the surround back channel consists of one channel of playback signals, but we recommend using two speakers. The modes that use the new ASA technology from THX (page 91) are most effective when using two monopole type surround back speakers placed close together.

Using two speakers results in a smoother blend with the sound of the surround channels and better sound positioning of the surround back channel when listening from a position other than the center.

### Placement of the surround left and right channels when using surround back speakers

Using surround back speakers greatly improves the positioning of the sound at the rear. Because of this, the surround left and right channels play an important role in achieving a smooth transition of the acoustic image from the front to the back. As shown on the diagram above, in a movie theater the surround signals are also produced from diagonally in front of the listeners, creating an acoustic image as if the sound were floating in space.

To achieve these effects, we recommend placing the speakers for the surround left and right channels slightly more towards the front than with conventional surround systems. Doing so sometimes increases the surround effect when playing conventional 5.1 channel sources in the THX Surround EX mode. Check the surround effects of the various modes before selecting the surround mode.

### Examples of speaker layouts

Below we introduce examples of speaker layouts. Refer to these to arrange your speakers according to their type and how you want to use them.

#### [1] For THX surround EX systems (Using surround back speakers)

##### ① When mainly playing movies

Recommended when your surround speakers are single or 2-way speakers.

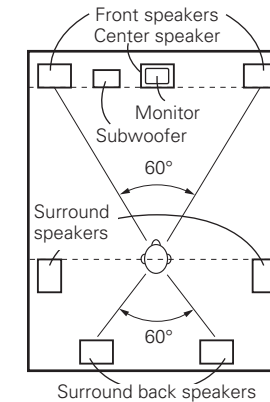

[As seen from above]

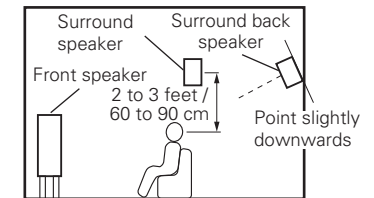

[As seen from the side]

## ② Setting for primarily watching movies using diffusion type speakers for the surround speakers

For the greatest sense of surround sound envelopment, diffuse radiation speakers such as bipolar (THX) types, or dipolar types, provide a wider dispersion than is possible to obtain from a direct radiating speaker (monopolar). Place these speakers at either side of the prime listening position, mounted above ear level.

### Path of the surround sound from the speakers to the listening position

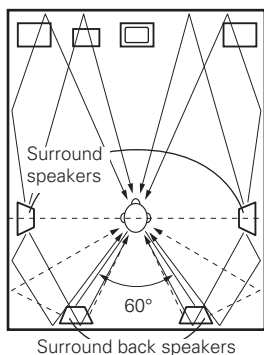

[As seen from above]

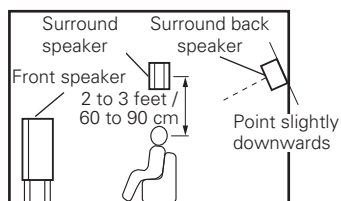

[As seen from the side]

## ③ When playing movies and music

To activate the appropriate speakers for movies and music, we suggest that during setup, choose Dolby Digital/DTS with THX and Surround Speakers A (the bipolar or dipolar speakers mounted at the sides of the listening position).

Choose Dolby Digital/DTS without THX and Surround Speakers B (the direct radiating speakers mounted at the rear corners of the listening room). Then, by simply activating the THX function (used during movie playback, the Surround A speakers are automatically activated. For multi-channel music listening (Dolby Digital or DTS music programs), turn off the THX enhancements by touching the THX button on the remote control, and the Surround B speakers will be automatically activated.

**Example:** Movie sources (Dolby, DTS Surround, etc.)  
 "THX" or "THX Cinema" mode ... Speakers A  
 Music sources (DVD video, DTS CD, etc.)  
 "Dolby/DTS Surround" ... Speakers B

The speakers can be switched at the touch of a button by turning HOME THX CINEMA on when playing movies and off when playing multi-channel music.

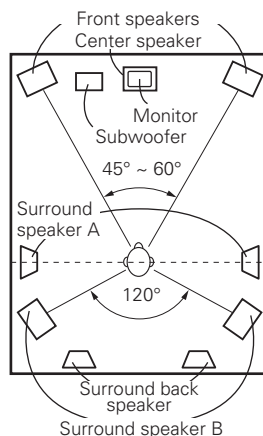

[As seen from above]

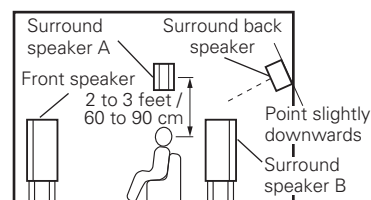

[As seen from the side]

## [2] When not using surround back speakers

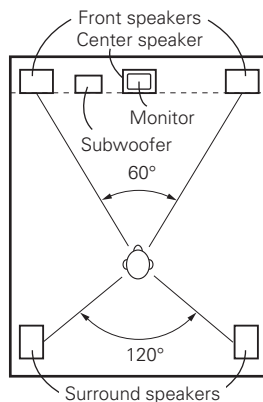

[As seen from above]

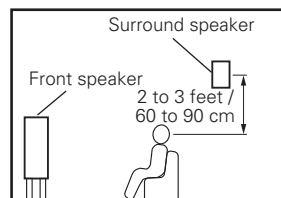

[As seen from the side]

## Surround

The AVP-A1HDCI is equipped with a digital signal processing circuit that lets you play program sources in the surround mode to achieve the same sense of presence as in a movie theater.

## Dolby Surround

### Dolby Digital

Dolby Digital is a multichannel digital signal format developed by Dolby Laboratories.

A total of 5.1-channels are played: 3 front channels ("FL", "FR" and "C"), 2 surround channels ("SL" and "SR") and the "LFE" channel for low frequencies.

Because of this, there is no crosstalk between channels and a realistic sound field with a "three-dimensional" feeling (sense of distance, movement and positioning) is achieved.

A real, overpowering sense of presence is achieved when playing movie sources in AV rooms as well.

### Dolby Digital Plus

Dolby Digital Plus is an improved Dolby Digital signal format that is compatible with up to 7.1-channels of discrete digital sound and also improves sound quality thanks to extra data bit rate performance. It is upwardly compatible with conventional Dolby Digital, so it offers greater flexibility in response to the source signal and the conditions of the playback equipment.

### Dolby TrueHD

Dolby TrueHD is a high definition audio technology developed by Dolby Laboratories, using lossless coding technology to faithfully reproduce the sound of the studio master.

This format is compatible with a maximum sampling frequency of 96 kHz and up to 7.1-channels, so it is used for applications particularly prioritizing sound quality.

## **Dolby Pro Logic II**

Dolby Pro Logic II is a matrix decoding technology developed by Dolby Laboratories.

Regular music such as that on CDs is encoded into 5-channels to achieve an excellent surround effect.

The surround channel signals are converted into stereo and full band signals (with a frequency response of 20 Hz to 20 kHz or greater) to create a “three-dimensional” sound image offering a rich sense of presence for all stereo sources.

## **Dolby Pro Logic IIx**

Dolby Pro Logic IIx is a further improved version of the Dolby Pro Logic II matrix decoding technology.

Audio signals recorded in 2-channels are decoded to achieve a natural sound with up to 7.1-channels.

There are 3 modes: “Music” suited for playing music, “Cinema” suited for playing movies, and “Game” which is optimized for playing games.

## **Dolby Headphone**

This is a three-dimensional sound technology developed jointly by Dolby Laboratories and Lake Technology Ltd. of Australia for achieving surround sound using regular headphones.

Previously, when using headphones all the sounds resonated inside the head and it was uncomfortable to listen with headphones for long periods of time. Dolby Headphone simulates speaker playback in a room and places the sound at the front or the sides, outside the head, to achieve a powerful sound like the sound of movie or home theaters.

This technology is mainly for multichannel audio/video equipment with Dolby Digital or Dolby Pro Logic Surround decoding functions and works with a high performance digital signal processing (DSP) chip.

Dolby Headphone is effective not only for multichannel sources but also for stereo programs.

On the AVP-A1HDCI, it is possible to output signals encoded in the Dolby Headphone mode from the recording output terminal and record them on a separate recorder.

## **Dolby Digital EX**

Dolby Digital EX is a 6.1-channel surround format proposed by Dolby Laboratories that allows users to enjoy in their homes the “DOLBY DIGITAL SURROUND EX” audio format jointly developed by Dolby Laboratories and Lucas Films.

The 6.1 channels of sound, including surround back channels, provide improved sound positioning and expression of space.

### **※ Sources recorded in Dolby Surround**

Sources recorded in Dolby Surround are indicated with the following logo marks.

Dolby Surround support mark : 

Manufactured under license from Dolby Laboratories. “Dolby”, “Pro Logic” and the double-D symbol are trademarks of Dolby Laboratories.

## **DTS Surround**

### **DTS Digital Surround**

DTS Digital Surround is the standard digital surround format of DTS, Inc., compatible with a sampling frequency of 44.1 or 48 kHz and up to 5.1-channels of digital discrete surround sound.

### **DTS-HD High Resolution Audio**

DTS-HD High Resolution Audio is an improved version of the conventional DTS, DTS-ES and DTS 96/24 signals formats, compatible with sampling frequencies of 96 or 48 kHz and up to 7.1-channels of discrete digital sound. High data bit rate performance provides high quality sound. This format is fully compatible with conventional products, including conventional DTS digital surround 5.1-channel data.

### **DTS-HD Master Audio**

DTS-HD Master Audio is DTS, Inc.’s lossless audio format compatible with up to 96 kHz/7.1-channels. The lossless audio coding technology faithfully reproduces the sound of the studio master. It is fully compatible with conventional products, including conventional DTS digital surround 5.1-channel data.

### **DTS-ES™ Discrete 6.1**

DTS-ES™ Discrete 6.1 is a 6.1-channel discrete digital audio format adding a surround back (SB) channel to the DTS digital surround sound. Decoding of conventional 5.1-channel audio signals is also possible according to the decoder.

### **DTS-ES™ Matrix 6.1**

DTS-ES™ Matrix 6.1 is a 6.1-channel discrete digital audio format inserting a surround back (SB) channel to the DTS digital surround sound through matrix encoding. Decoding of conventional 5.1-channel audio signals is also possible according to the decoder.

### **DTS NEO:6™ Surround**

DTS NEO:6™ is a matrix decoding technology for achieving 6.1-channel surround playback with 2-channel sources. It includes “DTS NEO:6 CINEMA” suited for playing movies and “DTS NEO:6 MUSIC” suited for playing music.

## **DTS 96/24**

DTS 96/24 is a digital audio format enabling high sound quality playback in 5.1-channels with a sampling frequency of 96 kHz and 24 bit quantization on DVD-Video.

Manufactured under license under U.S. Patent #'s: 5,451,942; 5,956,674; 5,974,380; 5,978,762; 6,226,616; 6,487,535 & other U.S. and worldwide patents issued & pending. DTS is a registered trademark and the DTS logos, Symbol, DTS-HD and DTS-HD Master Audio are trademarks of DTS, Inc.© 1996-2007 DTS, Inc. All Rights Reserved.

## **Home THX Cinema Surround**

THX is an exclusive set of standards and technologies established by the world-renowned film production company, Lucasfilm Ltd. THX grew from George Lucas’ personal desire to make your experience of the film soundtrack, in both movie theaters and in your home theater, as faithful as possible to what the director intended.

Movie soundtracks are mixed in special movie theaters called dubbing stages and are designed to be played back in movie theaters with similar equipment and conditions. The soundtrack created for movie theaters is then transferred directly onto Laserdisc, VHS tape, DVD, etc., and is not changed for playback in a small home theater environment.

THX engineers developed patented technologies to accurately translate the sound from the movie theater environment into the home, correcting the tonal and spatial errors that occur. On the AVP-A1HDCI, when the Home THX Cinema mode is on, THX post-processing is automatically added after the Dolby Pro Logic, Dolby Digital or DTS decoder:

### **Re-EQ™ (Re-Equalization)**

The tonal balance of a film soundtrack will be excessively bright and harsh when played back over audio equipment in the home because film soundtracks are designed to be played back in large movie theaters using very different professional equipment. Re-Equalization restores the correct tonal balance for listening to a movie soundtrack in a normal home environment.

## **Timbre Matching™**

The human ear changes our perception of a sound depending on the direction from which the sound is coming. In a movie theater, there is an array of surround speakers so that the surround information is all around you. In a home theater, only two speakers located to the side of your head are used. The Timbre Matching feature filters the information going to the surround speakers so that they more closely match the tonal characteristics of the sound coming from the front speakers. This ensures seamless panning between the front and surround speakers.

## **Adaptive Decorrelation™**

In a movie theater, a large number of surround speakers help create an enveloping surround sound experience, while in a home theater there are usually only two speakers. This can make the surround speakers sound like headphones that lack spaciousness and envelopment. The surround sounds will also collapse into the closest speaker as you move away from the middle seating position. Adaptive Decorrelation slightly changes one surround channel's time and phase relationship with respect to the other surround channel. This expands the listening position and creates—with only two speakers—the same spacious surround experience as in a movie theater.

## **THX Ultra2™**

Before any home theater component can be THX Ultra2 certified, it must incorporate all the features above and also pass a rigorous series of quality and performance tests. Only then can a product feature the THX Ultra2 logo, which is your guarantee that the Home Theater products you purchase will give you superb performance for many years to come. THX Ultra2 requirements cover every aspect of the product including power amplifier performance, pre-amplifier performance and operation, as well as hundreds of other parameters in both the digital and analog domain.

In addition to improvements to the power amplifier with respect to previous THX Ultra standards, three surround modes have been added: the THX Ultra2 Cinema mode, THX Music Mode and THX Games Mode.

## **THX Ultra2 Cinema**

THX Ultra2 Cinema mode plays 5.1 movies using all 8 speakers giving you the best possible movie watching experience. In this mode, new THX processing blends the side surround speakers and back surround speakers providing the optimal mix of ambient and directional surround sounds.

DTS-ES (Matrix and 6.1 Discrete) and Dolby Digital Surround EX encoded soundtracks will be automatically detected in Ultra2 Cinema mode if the appropriate flag has been encoded.

Some Dolby Digital Surround EX soundtracks are missing the digital flag that allows automatic switching. If you know that the movie that you are watching is encoded in Surround EX, you can manually select the THX Surround EX playback mode, otherwise THX Ultra2 Cinema mode will apply processing to provide optimum replay.

## **THX Music Mode**

For the replay of 5.1 multi-channel music the THX Music Mode should be selected. In this mode new THX processing is applied to the surround channels of all 5.1 encoded music sources such as DTS and Dolby Digital to provide a wide stable rear soundstage.

## **THX Games Mode**

For the replay of stereo and multi-channel game audio the THX Games Mode should be selected. In this mode THX ASA processing is applied to the surround channels of all 5.1 and 2.0 encoded game sources such as analog, PCM, DTS and Dolby Digital. This accurately places all game audio surround information, providing a full 360 degree playback environment. THX Games Mode is unique as it gives you a smooth transition of audio in all points of the surround field.

## **ASA (Advanced Speaker Array)**

ASA is a proprietary THX technology which processes the sound fed to 2 side and 2 back surround speakers to provide the optimal surround sound experience. When you set up your home theater system using all eight speaker outputs (Left, Center, Right, Surround Right, Surround Back Right, Surround Back Left, Surround Left and Subwoofer) placing the two Surround Back speakers close together facing the front of the room as shown in the diagram will provide the largest sweet spot. If for practical reasons you have to place the Surround Back speakers apart, you will need to go THX Audio Set-up screen and choose the setting that most closely corresponds to the speaker spacing, which will re-optimize the surround sound-field.

ASA is used in three new modes; THX Ultra2 Cinema, THX Music Mode and THX Games Mode.

## **Boundary Gain Compensation**

If your chosen listening room layout (for practical or aesthetic reasons) results in the most of the listeners being close to the rear wall, the resulting bass level can be sufficiently reinforced by the boundary that the overall sound quality becomes “boomy”. THX Ultra2 receivers and controllers contain the BGC (Boundary Gain Compensation) feature to provide an improved bass balance. BGC can be selected by choosing “THX Ultra2 Subwoofer–Yes” from the “Boundary Gain Compensation” section of the THX Audio setup menu.

THX and Re-EQ, THX Timbre Matching, THX Adaptive Decorrelation, and THX Advanced Speaker Array are trademarks of THX Ltd. THX may be registered in some jurisdictions. All rights reserved.

## **THX™ Surround EX™**

In 1999, a new surround system was launched simultaneously with the release of the movie “Star Wars Episode I”. “Dolby Digital Surround EX” is a new movie sound track that greatly enhances the sense of spatial expression and the positioning of the surround channel sound. The result is 360 degrees of movement and moving sound effects that seem to pass right over the listener's head. This system was developed jointly by THX and Dolby Laboratories, fusing THX's idea of improving spatial expression and achieving a uniform 360 degree sound positioning with Dolby Laboratories' matrix encoding technology. Emphasis was placed on compatibility with the existing system Dolby Digital 5.1 channel, and the new “surround back (SB) channel” was added to achieve improvements over the conventional 5.1 channel system in terms of the positioning of the sound at the rear, the acoustic image of sound moving from the two sides to the back as well as sound moving from the front to the center rear with the multi surround speaker systems used in movie theaters, thereby enabling various types of surround sound. The surround back channel signal is a matrix-encoded signal inserted into both the Dolby Digital SL (surround left) and SR (surround right) channels. Upon playback, the signals are decoded by a high precision digital matrix decoder within the Dolby Digital decoder into the SL, SR and SB channels and output as 6.1 channels of signals. With the AVP-A1HDCl, the signals further undergo Home THX Cinema processing to achieve a THX Surround EX system. Even without the proper environment for playing the SB channel, Dolby Digital Surround EX signals are 100% compatible with existing 5.1 channel playback systems, so they can be played as such. In this case, the SB channel signal is produced as a monaural signal from both the SL and SR channels, so none of the signal components are missing. The effects specific to THX Surround EX (the sense of spatial expression and the positioning of the sound), however, are the same as with conventional 5.1 channel surround systems.



THX and Ultra2 are trademarks of THX Ltd. THX may be registered in some jurisdictions. All rights reserved. Surround EX is a trademark of Dolby Laboratories. Used with permission.

## Neural Surround

Neural Surround™, a breakthrough in audio technology, will bring the excitement of surround music to more of America's listening audience. It provides the rich envelopment and discrete image detail of surround sound in a format 100 % compatible with stereo. With superior spectral resolution and channel separation, Neural Surround™ draws the brain's attention to sonic details in musical instruments, vocals, and ambience that are typically masked by other playback systems. This allows the listener to fully experience the richness and subtleties in recorded performance as never before. As the chosen format for XM Satellite Radio's new XM HD surround programming, Neural Surround will help deliver more surround music to more listeners than any other broadcast format. XM Satellite Radio will be the first radio company to broadcast surround sound on the radio 24 hours a day and will offer three channels fully dedicated to Neural Surround™ music. This alone will amount to more than 25,000 hours of Neural Surround™ music each year.



This product is manufactured under license from Neural Audio Corporation.

D&M Holdings Inc. hereby grants the user a non-exclusive, nontransferable, limited license right exercisable to use the NA SURROUND Technology and other US and World Wide Patents Pending technology.

"Neural" and "Neural Audio" and "Neural Surround" are trademarks of Neural Audio Corporation. All Rights Reserved.

## Audyssey

### Audyssey MultEQ® XT

Audyssey MultEQ® XT is the first technology to properly measure sound information throughout a listening area, then combine this information to accurately represent the acoustical problems in the room. Based on these measurements, MultEQ XT calculates an equalization solution that corrects for both time and frequency response problems in every seat. Audyssey MultEQ XT not only corrects frequency response problem in a large listening area but also performs a fully automated surround system setup.

For a detailed description, see page 26.

## Audyssey Dynamic EQ™

Audyssey Dynamic EQ solves the problem of deteriorating sound quality as volume is decreased by taking into account human perception and room acoustics. Dynamic EQ selects the best possible frequency response and surround levels moment-by-moment as volume is changed. The result is bass response, tonal balance and surround impression that remain constant despite changes in volume. This is the first technology to combine information from incoming source levels with actual output sound levels in the room, a pre-requisite for delivering a loudness correction solution. Audyssey Dynamic EQ works in tandem with Audyssey MultEQ to provide well-balanced sound for every listener at any volume level.



Manufactured under license from Audyssey Laboratories. U.S. and foreign patents pending. Audyssey MultEQ® XT is a registered trademark of Audyssey Laboratories. Dynamic EQ™ is a trademark of Audyssey Laboratories.

For more information, visit [www.audyssey.com](http://www.audyssey.com).

## HDCD® (High Definition Compatible Digital®)

HDCD® is an encoding/decoding technology that greatly reduces the distortion that occurs upon digital recording while maintaining compatibility with the conventional CD format, thus expanding the dynamic range and achieving a high resolution.

Conventional CDs and HDCD compatible CDs are identified automatically to select the optimum digital processing.

HDCD®, HDCD®, High Definition Compatible Digital® and Microsoft® are either registered trademarks or trademarks of Microsoft Corporation, Inc. in the United States and/or other countries. HDCD system manufactured under license from Microsoft Corporation, Inc. This product is covered by one or more of the following: In the USA: 5,479,168, 5,638,074, 5,640,161, 5,808,574, 5,838,274, 5,854,600, 5,864,311, 5,872,531, and in Australia: 669114. Other patents pending.

## DENON LINK

DENON LINK is a unique digital, balanced transfer type interface developed by DENON. It offers high speed, high quality transfer of digital audio data with low signal loss. It can be used together with DENON DVD players equipped with a special DENON LINK connector using a single cable to enable playback with high sound quality.

It allows digital transfer of the 192 kHz/24 bit 2-channel digital signals of DVD-Audio discs, PCM multi-channel signals, etc. Full-spec digital transfer of the audio contents of Super Audio CD is possible by connecting a player equipped for DENON LINK 3rd Edition.

## Advanced AL24 Processing Multi channel

### Equipped with "Advanced AL24 Processing" time axis region information volume expansion

In addition to the existing "AL24 Processing Plus" bit expansion technology, DENON has also developed "Advanced AL24 Processing" that dramatically improves information volume in the time axis region using high-speed signal detection and processing technology. In addition to expanding original 16-bit digital data to 24 bits, "Advanced AL24 Processing" uses data interpolation along the time axis or up-converted sampling to achieve natural interpolation without losing the original data. A digital filter is used to further expand adaptability and perform optimum filtering calculations for ringing-free pulse response, pulsive music data and attack sounds.

This results in the reproduction of such spatial information as the delicate nuances in the music, the positions of the performers, and the breadth, height, and depth of the concert hall. "Advanced AL24 Processing" is conducted for all channels and modes other than DSD DIRECT.

## HDMI (High-Definition Multimedia Interface)

HDMI is a digital interface standard for next generation TVs based on DVI (Digital Visual Interface) standards and optimized for use in consumer equipment.

Non-compressed digital video and multi-channel audio signals are transmitted with a single connection.

HDMI is also compatible with HDCP (High-bandwidth Digital Contents Protection), a technology for protecting copyrights that encrypts digital video signals in the same way as with DVI.

### Deep Color

Eliminates on-screen color banding, for smooth tonal transitions and subtle gradations between colors.

Enables increased contrast ratio.

Can represent many times more shades of gray between black and white.

At 30-bit pixel depth, a four times improvement would be the minimum, and the typical improvement would be eight times or more.

### xvYCC

Next-generation "xvYCC" color space supports 1.8 times as many colors as existing HDTV signals.

Lets HDTVs display colors more accurately.

Enables displays with natural, vivid colors.

### Lip Sync

Because consumer electronics devices are using increasingly complex digital signal processing to enhance the clarity and detail of the content, synchronization of video and audio in user devices has become a greater challenge and could potentially require complex end-user adjustments. HDMI 1.3 incorporates an automatic video/audio syncing capability that allows devices to perform this synchronization automatically with total accuracy.

"HDMI", "HDMI logo" and "High-Definition Multimedia Interface" are trademarks or registered trademarks of HDMI Licensing LLC.

## Surround Modes and Parameters

| Surround Mode           | Signals and adjustability in the different modes |        |              |                   |           |   |          |          |         |           |            |
|-------------------------|--|--------|--------------|-------------------|-----------|---|----------|----------|---------|-----------|------------|
|                         | Channel output                                   |        |              |                   |           | Parameter (default values are shown in parentheses) |          |          |         |           |            |
|                         | Front L/R  | Center | Surround L/R | Surround Back L/R | Subwoofer | D. COMP *1  | DRC *2   | LFE *3   | AFDM *1 | SB CH Out | Cinema EQ. |
| PURE DIRECT, DIRECT     | ○  | ×      | ×            | ×                 | ⊙         | ○ (OFF)   | ○ (Auto) | ○ (0 dB) | ×       | ×         | ×          |
| DSD DIRECT              | ○  | ×      | ×            | ×                 | ×         | ×   | ×        | ×        | ×       | ×         | ×          |
| DSD MULTI DIRECT        | ○  | ⊙      | ⊙            | ⊙                 | ⊙         | ×   | ×        | ○ (0 dB) | ×       | ○         | ×          |
| MULTI CH DIRECT         | ○  | ⊙      | ⊙            | ⊙                 | ⊙         | ×   | ×        | ○ (0 dB) | ○ (ON)  | ○         | ×          |
| STEREO                  | ○  | ×      | ×            | ×                 | ⊙         | ○ (OFF)   | ○ (Auto) | ○ (0 dB) | ×       | ×         | ×          |
| EXT. IN                 | ○  | ⊙      | ⊙            | ⊙                 | ⊙         | ×   | ×        | ×        | ×       | ○ (NOTE6) | ×          |
| MULTI CH IN             | ○  | ⊙      | ⊙            | ⊙                 | ⊙         | ×   | ×        | ○ (0 dB) | ○ (ON)  | ○         | ×          |
| WIDE SCREEN             | ○  | ⊙      | ⊙            | ⊙                 | ⊙         | ○ (OFF)   | ○ (Auto) | ○ (0 dB) | ×       | ○         | ○ (OFF)    |
| HOME THX CINEMA (2ch)   | ○  | ⊙      | ⊙            | ⊙                 | ⊙         | ×   | ×        | ×        | ×       | ○         | ×          |
| HOME THX CINEMA (5.1ch) | ○  | ⊙      | ⊙            | ⊙                 | ⊙         | ×   | ×        | ○ (0 dB) | ○ (ON)  | ○         | ×          |
| DOLBY PRO LOGIC IIx     | ○  | ⊙      | ⊙            | ⊙                 | ⊙         | ○ (OFF)   | ○ (Auto) | ×        | ×       | ○         | ○ (NOTE1)  |
| DOLBY PRO LOGIC II      | ○  | ⊙      | ⊙            | ×                 | ⊙         | ○ (OFF)   | ○ (Auto) | ×        | ×       | ○         | ○ (NOTE2)  |
| DTS NEO:6               | ○  | ⊙      | ⊙            | ⊙                 | ⊙         | ○ (OFF)   | ○ (Auto) | ×        | ×       | ○         | ○ (NOTE1)  |
| DOLBY DIGITAL           | ○  | ⊙      | ⊙            | ⊙                 | ⊙         | ○ (OFF)   | ×        | ○ (0 dB) | ○ (ON)  | ○         | ○ (OFF)    |
| DOLBY DIGITAL Plus      | ○  | ⊙      | ⊙            | ⊙                 | ⊙         | ○ (OFF)   | ×        | ○ (0 dB) | ○ (ON)  | ○         | ○ (OFF)    |
| DOLBY TrueHD            | ○  | ⊙      | ⊙            | ⊙                 | ⊙         | ×   | ○ (Auto) | ○ (0 dB) | ○ (ON)  | ○         | ○ (OFF)    |
| DTS SURROUND            | ○  | ⊙      | ⊙            | ⊙                 | ⊙         | ○ (OFF)   | ×        | ○ (0 dB) | ○ (ON)  | ○         | ○ (OFF)    |
| DTS 96/24               | ○  | ⊙      | ⊙            | ⊙                 | ⊙         | ○ (OFF)   | ×        | ○ (0 dB) | ○ (ON)  | ○         | ○ (OFF)    |
| DTS-HD                  | ○  | ⊙      | ⊙            | ⊙                 | ⊙         | ○ (OFF)   | ×        | ○ (0 dB) | ○ (ON)  | ○         | ○ (OFF)    |
| neural                  | ○  | ⊙      | ⊙            | ⊙                 | ⊙         | ×   | ×        | ×        | ×       | ○         | ×          |
| 7CH STEREO              | ○  | ⊙      | ⊙            | ⊙                 | ⊙         | ○ (OFF)   | ○ (Auto) | ○ (0 dB) | ×       | ○         | ×          |
| SUPER STADIUM           | ○  | ⊙      | ⊙            | ⊙                 | ⊙         | ○ (OFF)   | ○ (Auto) | ○ (0 dB) | ×       | ○         | ×          |
| ROCK ARENA              | ○  | ⊙      | ⊙            | ⊙                 | ⊙         | ○ (OFF)   | ○ (Auto) | ○ (0 dB) | ×       | ○         | ×          |
| JAZZ CLUB               | ○  | ⊙      | ⊙            | ⊙                 | ⊙         | ○ (OFF)   | ○ (Auto) | ○ (0 dB) | ×       | ○         | ×          |
| CLASSIC CONCERT         | ○  | ⊙      | ⊙            | ⊙                 | ⊙         | ○ (OFF)   | ○ (Auto) | ○ (0 dB) | ×       | ○         | ×          |
| MONO                    | ○  | ⊙      | ⊙            | ⊙                 | ⊙         | ○ (OFF)   | ○ (Auto) | ○ (0 dB) | ×       | ○         | ×          |
| VIDEO GAME              | ○  | ⊙      | ⊙            | ⊙                 | ⊙         | ○ (OFF)   | ○ (Auto) | ○ (0 dB) | ×       | ○         | ×          |
| MATRIX                  | ○  | ⊙      | ⊙            | ⊙                 | ⊙         | ○ (OFF)   | ○ (Auto) | ○ (0 dB) | ×       | ○         | ×          |
| DOLBY HEADPHONE         | ○  | ×      | ×            | ×                 | ×         | ×   | ×        | ×        | ×       | ×         | ×          |

○ : Signal / Adjustable

×

⊙ : Turned on or off by speaker configuration setting

NOTE1 : This parameter is available when the GUI menu "Parameter" - "Audio" - "Surround Parameters" - "Mode" is set to "Cinema" (page 52).

NOTE2 : This parameter is available when the GUI menu "Parameter" - "Audio" - "Surround Parameters" - "Mode" is set to "Cinema" or "Pro Logic" (page 52).

NOTE6 : This parameter can be used when GUI menu "Manual Setup" - "Audio Setup" - "EXT. IN Setup" - "Mode" is set to "DSP" (page 33)

#### NOTE:

\*1 : When playing Dolby Digital and DTS signals.

\*2 : When playing Dolby True HD signal.

\*3 : When playing Dolby Digital, DTS, DVD-Audio and Super Audio CD.



| Surround Mode           | Signals and adjustability in the different modes    |         |            |              |            |           |                                  |              |              |                       |                       |   |           |            |           |               |          |
|-------------------------|---|---------|------------|--------------|------------|-----------|----------------------------------|--------------|--------------|-----------------------|-----------------------|---|-----------|------------|-----------|---------------|----------|
|                         | Parameter (default values are shown in parentheses) |         |            |              |            |           |                                  |              |              |                       |                       |   |           |            |           |               |          |
|                         | Mode  | Decoder | Room Size  | Effect Level | Delay Time | Subwoofer | PRO LOGIC II/IIx MUSIC mode only |              |              | NEO:6 MUSIC mode only | EXT. IN only          |   | Tone *1   | Night Mode | Room EQ   | Dynamic EQ *2 | RESTORER |
| Panorama                |   |         |            |              |            |           | Dimension                        | Center Width | Center Image | Subwoofer Att.        | Input Channel (NOTE6) |   |           |            |           |               |          |
| PURE DIRECT, DIRECT     | ×   | ×       | ×          | ×            | ×          | ○         | ×                                | ×            | ×            | ×                     | ○                     | ○ | ×         | ○ (OFF)    | ○ (NOTE5) | ○ (NOTE5)     | ○        |
| DSD DIRECT              | ×   | ×       | ×          | ×            | ×          | ○         | ×                                | ×            | ×            | ×                     | ×                     | × | ×         | ×          | ×         | ×             | ×        |
| DSD MULTI DIRECT        | ×   | ×       | ×          | ×            | ×          | ×         | ×                                | ×            | ×            | ×                     | ×                     | × | ×         | ×          | ×         | ×             | ×        |
| MULTI CH DIRECT         | ×   | ×       | ×          | ×            | ×          | ×         | ×                                | ×            | ×            | ×                     | ○                     | ○ | ×         | ○ (OFF)    | ○ (NOTE5) | ○ (NOTE5)     | ×        |
| STEREO                  | ×   | ×       | ×          | ×            | ×          | ×         | ×                                | ×            | ×            | ×                     | ○                     | ○ | ○ (0 dB)  | ○ (OFF)    | ○ (OFF)   | ○ (OFF)       | ○        |
| EXT. IN                 | ×   | ×       | ×          | ×            | ×          | ×         | ×                                | ×            | ×            | ×                     | ○                     | ○ | ×         | ×          | ×         | ×             | ×        |
| MULTI CH IN             | ×   | ×       | ×          | ×            | ×          | ×         | ×                                | ×            | ×            | ×                     | ○                     | ○ | ○ (0 dB)  | ○ (OFF)    | ○ (OFF)   | ○ (OFF)       | ×        |
| WIDE SCREEN             | ×   | ×       | ×          | ○ (ON, 10)   | ×          | ×         | ×                                | ×            | ×            | ×                     | ○                     | ○ | ○ (0 dB)  | ○ (OFF)    | ○ (OFF)   | ○ (OFF)       | ○        |
| HOME THX CINEMA (2ch)   | ○ (PLIIx C)   | ○       | ×          | ×            | ×          | ×         | ×                                | ×            | ×            | ×                     | ○                     | ○ | ×         | ○ (OFF)    | ○ (OFF)   | ○ (OFF)       | ○        |
| HOME THX CINEMA (5.1ch) | ×   | ×       | ×          | ×            | ×          | ×         | ×                                | ×            | ×            | ×                     | ○                     | ○ | ×         | ○ (OFF)    | ○ (OFF)   | ○ (OFF)       | ×        |
| DOLBY PRO LOGIC IIx     | ○ (Cinema)  | ×       | ×          | ×            | ×          | ×         | ○ (OFF)                          | ○ (3)        | ○ (3)        | ×                     | ×                     | × | ○ (0 dB)  | ○ (OFF)    | ○ (OFF)   | ○ (OFF)       | ○        |
| DOLBY PRO LOGIC II      | ○ (Cinema)  | ×       | ×          | ×            | ×          | ×         | ○ (OFF)                          | ○ (3)        | ○ (3)        | ×                     | ×                     | × | ○ (0 dB)  | ○ (OFF)    | ○ (OFF)   | ○ (OFF)       | ○        |
| DTS NEO:6               | ○ (Cinema)  | ×       | ×          | ×            | ×          | ×         | ×                                | ×            | ×            | ○ (0.3)               | ×                     | × | ○ (0 dB)  | ○ (OFF)    | ○ (OFF)   | ○ (OFF)       | ○        |
| DOLBY DIGITAL           | ×   | ×       | ×          | ×            | ×          | ×         | ×                                | ×            | ×            | ×                     | ×                     | × | ○ (0 dB)  | ○ (OFF)    | ○ (OFF)   | ○ (OFF)       | ×        |
| DOLBY DIGITAL Plus      | ×   | ×       | ×          | ×            | ×          | ×         | ×                                | ×            | ×            | ×                     | ×                     | × | ○ (0 dB)  | ×          | ○ (OFF)   | ○ (OFF)       | ×        |
| DOLBY TrueHD            | ×   | ×       | ×          | ×            | ×          | ×         | ×                                | ×            | ×            | ×                     | ×                     | × | ○ (0 dB)  | ×          | ○ (OFF)   | ○ (OFF)       | ×        |
| DTS SURROUND            | ×   | ×       | ×          | ×            | ×          | ×         | ×                                | ×            | ×            | ×                     | ○                     | ○ | ○ (0 dB)  | ○ (OFF)    | ○ (OFF)   | ○ (OFF)       | ×        |
| DTS 96/24               | ×   | ×       | ×          | ×            | ×          | ×         | ×                                | ×            | ×            | ×                     | ×                     | × | ○ (0 dB)  | ○ (OFF)    | ○ (OFF)   | ○ (OFF)       | ×        |
| DTS-HD                  | ×   | ×       | ×          | ×            | ×          | ×         | ×                                | ×            | ×            | ×                     | ×                     | × | ○ (0 dB)  | ×          | ○ (OFF)   | ○ (OFF)       | ×        |
| neural                  | ×   | ×       | ×          | ×            | ×          | ×         | ×                                | ×            | ×            | ×                     | ×                     | × | ○ (0 dB)  | ○ (OFF)    | ○ (OFF)   | ○ (OFF)       | ○        |
| 7CH STEREO              | ×   | ×       | ×          | ×            | ×          | ×         | ×                                | ×            | ×            | ×                     | ○                     | ○ | ○ (0 dB)  | ○ (OFF)    | ○ (OFF)   | ○ (OFF)       | ○        |
| SUPER STADIUM           | ×   | ×       | ○ (Medium) | ○ (10)       | ×          | ×         | ×                                | ×            | ×            | ×                     | ○                     | ○ | ○ (NOTE3) | ○ (OFF)    | ○ (OFF)   | ○ (OFF)       | ○        |
| ROCK ARENA              | ×   | ×       | ○ (Medium) | ○ (10)       | ×          | ×         | ×                                | ×            | ×            | ×                     | ○                     | ○ | ○ (NOTE4) | ○ (OFF)    | ○ (OFF)   | ○ (OFF)       | ○        |
| JAZZ CLUB               | ×   | ×       | ○ (Medium) | ○ (10)       | ×          | ×         | ×                                | ×            | ×            | ×                     | ○                     | ○ | ○ (0 dB)  | ○ (OFF)    | ○ (OFF)   | ○ (OFF)       | ○        |
| CLASSIC CONCERT         | ×   | ×       | ○ (Medium) | ○ (10)       | ×          | ×         | ×                                | ×            | ×            | ×                     | ○                     | ○ | ○ (0 dB)  | ○ (OFF)    | ○ (OFF)   | ○ (OFF)       | ○        |
| MONO                    | ×   | ×       | ○ (Medium) | ○ (0)        | ×          | ×         | ×                                | ×            | ×            | ×                     | ○                     | ○ | ○ (0 dB)  | ○ (OFF)    | ○ (OFF)   | ○ (OFF)       | ○        |
| VIDEO GAME              | ×   | ×       | ○ (Medium) | ○ (10)       | ×          | ×         | ×                                | ×            | ×            | ×                     | ○                     | ○ | ○ (0 dB)  | ○ (OFF)    | ○ (OFF)   | ○ (OFF)       | ○        |
| MATRIX                  | ×   | ×       | ×          | ×            | ○ (30 ms)  | ×         | ×                                | ×            | ×            | ×                     | ○                     | ○ | ○ (0 dB)  | ○ (OFF)    | ○ (OFF)   | ○ (OFF)       | ○        |
| DOLBY HEADPHONE         | ×   | ○       | ×          | ×            | ×          | ×         | ×                                | ×            | ×            | ×                     | ×                     | × | ○ (0 dB)  | ○ (OFF)    | ○ (OFF)   | ○ (OFF)       | ○        |

○ : Signal / Adjustable

× : No signal / Not adjustable

NOTE3 : BASS +6 dB, TREBLE 0 dB

NOTE4 : BASS +6 dB, TREBLE +4 dB

NOTE5 : Can be used according to the "Direct Mode" setting.

NOTE6 : "DSP" mode only

\*1 : When "Dynamic EQ" is set to "ON", you cannot use the "Tone" setting.

\*2 : Can be set when GUI menu "Parameter" - "Audio" - "Room EQ" is set to "Audyssey", "Audyssey Flat", "Audyssey Byp.L/R".



| Button         | Surround mode                     | Note | Input signals |                  |   |                     |                              |                          |                         |             |           |              |                    |                              |                                 |                           |                       |                     |                      |                 |                |           |   |
|----------------|-----------------------------------|------|---------------|------------------|---|---------------------|------------------------------|--------------------------|-------------------------|-------------|-----------|--------------|--------------------|------------------------------|---------------------------------|---------------------------|-----------------------|---------------------|----------------------|-----------------|----------------|-----------|---|
|                |                                   |      | ANALOG        | LINEAR PCM / WAV | WMA (Windows Media Audio) / MP3 / MPEG-4 AAC / FLAC | DTS-HD              |                              | DTS                      |                         |             | DOLBY     |              | DOLBY DIGITAL      |                              |                                 |                           |                       | DVD-AUDIO           |                      | Super Audio CD  |                |           |   |
|                |                                   |      |               |                  |   | DTS-HD Master Audio | DTS-HD High Resolution Audio | DTS ES DSCRT (With Flag) | DTS ES MTRX (With Flag) | DTS (5.1ch) | DTS 96/24 | DOLBY TrueHD | DOLBY DIGITAL Plus | DOLBY DIGITAL EX (With Flag) | DOLBY DIGITAL EX (With no Flag) | DOLBY DIGITAL (5.1/5/4ch) | DOLBY DIGITAL (4/3ch) | DOLBY DIGITAL (2ch) | DVD-Audio (multi ch) | DVD-Audio (2ch) | DSD (multi ch) | DSD (2ch) |   |
| STANDARD       |                                   |      |               |                  |   |                     |                              |                          |                         |             |           |              |                    |                              |                                 |                           |                       |                     |                      |                 |                |           |   |
| DOLBY SURROUND |                                   |      |               |                  |   |                     |                              |                          |                         |             |           |              |                    |                              |                                 |                           |                       |                     |                      |                 |                |           |   |
|                | DOLBY TrueHD                      |      | ×             | ×                | ×   | ×                   | ×                            | ×                        | ×                       | ×           | ×         | ●            | ×                  | ×                            | ×                               | ×                         | ×                     | ×                   | ×                    | ×               | ×              | ×         |   |
|                | DOLBY DIGITAL+                    |      | ×             | ×                | ×   | ×                   | ×                            | ×                        | ×                       | ×           | ×         | ×            | ●                  | ×                            | ×                               | ×                         | ×                     | ×                   | ×                    | ×               | ×              | ×         |   |
|                | DOLBY DIGITAL EX                  | *1   | ×             | ×                | ×   | ×                   | ×                            | ×                        | ×                       | ×           | ×         | ×            | ×                  | ○                            | ○                               | ○                         | ○                     | ×                   | ×                    | ×               | ×              | ×         |   |
|                | DOLBY (D+) (HD) +EX               | *1   | ×             | ×                | ×   | ×                   | ×                            | ×                        | ×                       | ×           | ×         | ○            | ○                  | ×                            | ×                               | ×                         | ×                     | ×                   | ×                    | ×               | ×              | ×         |   |
|                | DOLBY DIGITAL                     |      | ×             | ×                | ×   | ×                   | ×                            | ×                        | ×                       | ×           | ×         | ×            | ×                  | ○                            | ●                               | ●                         | ●                     | ×                   | ×                    | ×               | ×              | ×         |   |
|                | DOLBY (D) (D+) (HD) +PLIIx CINEMA | *2   | ×             | ×                | ×   | ×                   | ×                            | ×                        | ×                       | ×           | ×         | ○            | ○                  | ●◎                           | ○                               | ○                         | ○                     | ×                   | ×                    | ×               | ×              | ×         |   |
|                | DOLBY (D) (D+) (HD) +PLIIx MUSIC  | *1   | ×             | ×                | ×   | ×                   | ×                            | ×                        | ×                       | ×           | ×         | ○            | ○                  | ○                            | ○                               | ○                         | ○                     | ×                   | ×                    | ×               | ×              | ×         |   |
|                | DOLBY PRO LOGIC IIx CINEMA        | *1   | ○             | ○                | ○   | ×                   | ×                            | ×                        | ×                       | ×           | ×         | ×            | ×                  | ×                            | ×                               | ×                         | ×                     | ○                   | ×                    | ○               | ×              | ○         |   |
|                | DOLBY PRO LOGIC IIx MUSIC         | *1   | ○             | ○                | ○   | ×                   | ×                            | ×                        | ×                       | ×           | ×         | ×            | ×                  | ×                            | ×                               | ×                         | ×                     | ○                   | ×                    | ○               | ×              | ○         |   |
|                | DOLBY PRO LOGIC IIx GAME          | *1   | ○             | ○                | ○   | ×                   | ×                            | ×                        | ×                       | ×           | ×         | ×            | ×                  | ×                            | ×                               | ×                         | ×                     | ○                   | ×                    | ○               | ×              | ○         |   |
|                | DOLBY PRO LOGIC II CINEMA         |      | ○             | ○                | ○   | ×                   | ×                            | ×                        | ×                       | ×           | ×         | ×            | ×                  | ×                            | ×                               | ×                         | ×                     | ○                   | ×                    | ○               | ×              | ○         |   |
|                | DOLBY PRO LOGIC II MUSIC          |      | ○             | ○                | ○   | ×                   | ×                            | ×                        | ×                       | ×           | ×         | ×            | ×                  | ×                            | ×                               | ×                         | ×                     | ○                   | ×                    | ○               | ×              | ○         |   |
|                | DOLBY PRO LOGIC II GAME           |      | ○             | ○                | ○   | ×                   | ×                            | ×                        | ×                       | ×           | ×         | ×            | ×                  | ×                            | ×                               | ×                         | ×                     | ○                   | ×                    | ○               | ×              | ○         |   |
|                | DOLBY PRO LOGIC                   |      | ○             | ○                | ○   | ×                   | ×                            | ×                        | ×                       | ×           | ×         | ×            | ×                  | ×                            | ×                               | ×                         | ×                     | ○                   | ×                    | ○               | ×              | ○         |   |
|                | DOLBY HEADPHONE                   | *4   | ○             | ○                | ○   | ○                   | ○                            | ○                        | ○                       | ○           | ○         | ○            | ○                  | ○                            | ○                               | ○                         | ○                     | ○                   | ○                    | ○               | ○              | ○         |   |
|                | neural                            |      | ○             | ○                | ○   | ×                   | ×                            | ×                        | ×                       | ×           | ×         | ×            | ×                  | ×                            | ×                               | ×                         | ×                     | ×                   | ×                    | ×               | ×              | ×         |   |
| MULTI CH IN    |                                   |      |               |                  |   |                     |                              |                          |                         |             |           |              |                    |                              |                                 |                           |                       |                     |                      |                 |                |           |   |
|                | MULTI CH IN                       |      | ×             | ×                | ×   | ×                   | ×                            | ×                        | ×                       | ×           | ×         | ×            | ×                  | ×                            | ×                               | ×                         | ×                     | ×                   | ●                    | ×               | ●              | ×         |   |
|                | MULTI IN + PLIIx CINEMA           | *2   | ×             | ×                | ×   | ×                   | ×                            | ×                        | ×                       | ×           | ×         | ×            | ×                  | ×                            | ×                               | ×                         | ×                     | ×                   | ○                    | ×               | ○              | ×         |   |
|                | MULTI IN + PLIIx MUSIC            | *1   | ×             | ×                | ×   | ×                   | ×                            | ×                        | ×                       | ×           | ×         | ×            | ×                  | ×                            | ×                               | ×                         | ×                     | ×                   | ○                    | ×               | ○              | ×         |   |
|                | MULTI IN + Dolby EX               | *1   | ×             | ×                | ×   | ×                   | ×                            | ×                        | ×                       | ×           | ×         | ×            | ×                  | ×                            | ×                               | ×                         | ×                     | ×                   | ○                    | ×               | ○              | ×         |   |
|                | MULTI CH IN 7.1                   |      | ×             | ×                | ×   | ×                   | ×                            | ×                        | ×                       | ×           | ×         | ×            | ×                  | ×                            | ×                               | ×                         | ×                     | ×                   | ●◎ (7.1)             | ×               | ×              | ×         |   |
| DIRECT         |                                   |      |               |                  |   |                     |                              |                          |                         |             |           |              |                    |                              |                                 |                           |                       |                     |                      |                 |                |           |   |
|                | DIRECT                            |      | ○             | ○                | ○   | ○                   | ○                            | ○                        | ○                       | ○           | ○         | ○            | ○                  | ○                            | ○                               | ○                         | ○                     | ○                   | ○                    | ×               | ○              | ×         | ○ |
|                | DSD DIRECT                        |      | ×             | ×                | ×   | ×                   | ×                            | ×                        | ×                       | ×           | ×         | ×            | ×                  | ×                            | ×                               | ×                         | ×                     | ×                   | ×                    | ×               | ×              | ○         |   |
|                | DSD MULTI DIRECT                  |      | ×             | ×                | ×   | ×                   | ×                            | ×                        | ×                       | ×           | ×         | ×            | ×                  | ×                            | ×                               | ×                         | ×                     | ×                   | ×                    | ×               | ○              | ×         |   |
|                | MULTI CH DIRECT                   |      | ×             | ×                | ×   | ×                   | ×                            | ×                        | ×                       | ×           | ×         | ×            | ×                  | ×                            | ×                               | ×                         | ×                     | ×                   | ○                    | ×               | ○              | ×         |   |
|                | M DIRECT + PLIIx CINEMA           | *2   | ×             | ×                | ×   | ×                   | ×                            | ×                        | ×                       | ×           | ×         | ×            | ×                  | ×                            | ×                               | ×                         | ×                     | ×                   | ○                    | ×               | ○              | ×         |   |
|                | M DIRECT + PLIIx MUSIC            | *1   | ×             | ×                | ×   | ×                   | ×                            | ×                        | ×                       | ×           | ×         | ×            | ×                  | ×                            | ×                               | ×                         | ×                     | ×                   | ○                    | ×               | ○              | ×         |   |
|                | M DIRECT + Dolby EX               | *1   | ×             | ×                | ×   | ×                   | ×                            | ×                        | ×                       | ×           | ×         | ×            | ×                  | ×                            | ×                               | ×                         | ×                     | ×                   | ○                    | ×               | ○              | ×         |   |
|                | M DIRECT 7.1                      |      | ×             | ×                | ×   | ×                   | ×                            | ×                        | ×                       | ×           | ×         | ×            | ×                  | ×                            | ×                               | ×                         | ×                     | ×                   | ○ (7.1)              | ×               | ×              | ×         |   |

**NOTE:**

- \*1: This mode is not available when the surround back speaker setup is set to "None" (page 29).
- \*2: This mode is not available when the surround back speaker setup is set to "1spkr" or "None" (page 29).
- \*4: You can select this when the headphone plug is inserted into the headphone jack.

- : Mode selectable in initial status
- ◎ : Mode fixed when "AFDM" is "ON"
- : Selectable mode
- × : Non-selectable mode

| Button                  | Note | Input signals |                  |   |                     |                              |                          |                         |             |           |              |                    |                              |                                 |                           |                       |                     |                      |                 |                |           |
|-------------------------|------|---------------|------------------|---|---------------------|------------------------------|--------------------------|-------------------------|-------------|-----------|--------------|--------------------|------------------------------|---------------------------------|---------------------------|-----------------------|---------------------|----------------------|-----------------|----------------|-----------|
|                         |      | ANALOG        | LINEAR PCM / WAV | WMA (Windows Media Audio) / MP3 / MPEG-4 AAC / FLAC | DTS-HD              |                              | DTS                      |                         |             |           | DOLBY        |                    | DOLBY DIGITAL                |                                 |                           |                       |                     | DVD-AUDIO            |                 | Super Audio CD |           |
| Surround mode           |      |               |                  |   | DTS-HD Master Audio | DTS-HD High Resolution Audio | DTS ES DSCRT (With Flag) | DTS ES MTRX (With Flag) | DTS (5.1ch) | DTS 96/24 | DOLBY TrueHD | DOLBY DIGITAL Plus | DOLBY DIGITAL EX (With Flag) | DOLBY DIGITAL EX (With no Flag) | DOLBY DIGITAL (5.1/5/4ch) | DOLBY DIGITAL (4/3ch) | DOLBY DIGITAL (2ch) | DVD-Audio (multi ch) | DVD-Audio (2ch) | DSD (multi ch) | DSD (2ch) |
| PURE DIRECT             |      |               |                  |   |                     |                              |                          |                         |             |           |              |                    |                              |                                 |                           |                       |                     |                      |                 |                |           |
| PURE DIRECT             |      | ○             | ○                | ○   | ○                   | ○                            | ○                        | ○                       | ○           | ○         | ○            | ○                  | ○                            | ○                               | ○                         | ○                     | ○                   | ○                    | ○               | ○              | ○         |
| DSD PURE DIRECT         |      | ×             | ×                | ×   | ×                   | ×                            | ×                        | ×                       | ×           | ×         | ×            | ×                  | ×                            | ×                               | ×                         | ×                     | ×                   | ×                    | ×               | ×              | ○         |
| DSD MULTI PURE          |      | ×             | ×                | ×   | ×                   | ×                            | ×                        | ×                       | ×           | ×         | ×            | ×                  | ×                            | ×                               | ×                         | ×                     | ×                   | ×                    | ×               | ○              | ×         |
| MULTI CH PURE DIRECT    |      | ×             | ×                | ×   | ×                   | ×                            | ×                        | ×                       | ×           | ×         | ×            | ×                  | ×                            | ×                               | ×                         | ×                     | ×                   | ○                    | ×               | ○              | ×         |
| M PURE D + PLIIx CINEMA | *2   | ×             | ×                | ×   | ×                   | ×                            | ×                        | ×                       | ×           | ×         | ×            | ×                  | ×                            | ×                               | ×                         | ×                     | ×                   | ○                    | ×               | ○              | ×         |
| M PURE D + PLIIx MUSIC  | *1   | ×             | ×                | ×   | ×                   | ×                            | ×                        | ×                       | ×           | ×         | ×            | ×                  | ×                            | ×                               | ×                         | ×                     | ×                   | ○                    | ×               | ○              | ×         |
| M PURE D + Dolby EX     | *1   | ×             | ×                | ×   | ×                   | ×                            | ×                        | ×                       | ×           | ×         | ×            | ×                  | ×                            | ×                               | ×                         | ×                     | ×                   | ○                    | ×               | ○              | ×         |
| M CH PURE DIRECT 7.1    |      | ×             | ×                | ×   | ×                   | ×                            | ×                        | ×                       | ×           | ×         | ×            | ×                  | ×                            | ×                               | ×                         | ×                     | ×                   | ○ (7.1)              | ×               | ×              | ×         |
| DSP SIMULATION          |      |               |                  |   |                     |                              |                          |                         |             |           |              |                    |                              |                                 |                           |                       |                     |                      |                 |                |           |
| 7CH STEREO              | *5   | ○             | ○                | ○   | ○                   | ○                            | ○                        | ○                       | ○           | ○         | ○            | ○                  | ○                            | ○                               | ○                         | ○                     | ○                   | ○                    | ○               | ○              | ○         |
| WIDE SCREEN             |      | ○             | ○                | ○   | ○                   | ○                            | ○                        | ○                       | ○           | ○         | ○            | ○                  | ○                            | ○                               | ○                         | ○                     | ○                   | ○                    | ○               | ○              | ○         |
| SUPER STADIUM           |      | ○             | ○                | ○   | ○                   | ○                            | ○                        | ○                       | ○           | ○         | ○            | ○                  | ○                            | ○                               | ○                         | ○                     | ○                   | ○                    | ○               | ○              | ○         |
| ROCK ARENA              |      | ○             | ○                | ○   | ○                   | ○                            | ○                        | ○                       | ○           | ○         | ○            | ○                  | ○                            | ○                               | ○                         | ○                     | ○                   | ○                    | ○               | ○              | ○         |
| JAZZ CLUB               |      | ○             | ○                | ○   | ○                   | ○                            | ○                        | ○                       | ○           | ○         | ○            | ○                  | ○                            | ○                               | ○                         | ○                     | ○                   | ○                    | ○               | ○              | ○         |
| CLASSIC CONCERT         |      | ○             | ○                | ○   | ○                   | ○                            | ○                        | ○                       | ○           | ○         | ○            | ○                  | ○                            | ○                               | ○                         | ○                     | ○                   | ○                    | ○               | ○              | ○         |
| MONO                    |      | ○             | ○                | ○   | ○                   | ○                            | ○                        | ○                       | ○           | ○         | ○            | ○                  | ○                            | ○                               | ○                         | ○                     | ○                   | ○                    | ○               | ○              | ○         |
| VIDEO GAME              |      | ○             | ○                | ○   | ○                   | ○                            | ○                        | ○                       | ○           | ○         | ○            | ○                  | ○                            | ○                               | ○                         | ○                     | ○                   | ○                    | ○               | ○              | ○         |
| MATRIX                  |      | ○             | ○                | ○   | ○                   | ○                            | ○                        | ○                       | ○           | ○         | ○            | ○                  | ○                            | ○                               | ○                         | ○                     | ○                   | ○                    | ○               | ○              | ○         |
| STEREO                  |      |               |                  |   |                     |                              |                          |                         |             |           |              |                    |                              |                                 |                           |                       |                     |                      |                 |                |           |
| STEREO                  |      | ●             | ●                | ●   | ○                   | ○                            | ○                        | ○                       | ○           | ○         | ○            | ○                  | ○                            | ○                               | ○                         | ○                     | ○                   | ○                    | ○               | ○              | ○         |

**NOTE :**

- \*1: This mode is not available when the surround back speaker setup is set to "None" (page 29).
- \*2: This mode is not available when the surround back speaker setup is set to "1spkr" or "None" (page 29).
- \*5: If the surround back speaker setup is set to "None" and when using headphones, then "5CH STEREO" is displayed. "9CH STEREO" is displayed when surround (A+B) and the surround back speaker are used.

- : Mode selectable in initial status
- : Selectable mode
- × : Non-selectable mode

## About Networks

### Windows Media Player ver.11

This is a media player distributed free of charge by Microsoft Corporation.

It can be used to play playlists created with Windows Media Player ver. 11 as well as files in such formats as WMA, DRM WMA, MP3 and WAV.

### vTuner

This is a free online contents server for Internet radio. Note that usage fees are included in upgrade costs.

For inquiries about this service, visit the vTuner site below.

vTuner website: <http://www.radiodemon.com>

This product is protected by certain intellectual property rights of Nothing Else Matters Software and BridgeCo. Use or distribution of such technology outside of this product is prohibited without a license from Nothing Else Matters Software and BridgeCo or an authorized subsidiary.

### DLNA

- DLNA and DLNA CERTIFIED are trademarks and/or service marks of Digital Living Network Alliance.
- Some contents may not be compatible with other DLNA CERTIFIED™ products.

### Windows Media DRM

A copyright-protected technology developed by Microsoft.

- Windows Vista and the Windows logo are trademarks of the Microsoft group of companies.
- The PlaysForSure logo, Windows Media and the Windows logo are trademarks or registered trademarks of Microsoft Corporation in the United States and/or other countries.
- Content providers are using the digital rights management technology for Windows Media contained in this device (WM-DRM) to protect the integrity of their content (Secure Content) so that their intellectual property, including copyright, in such content is not misappropriated. This device uses WM-DRM software to play Secure Content (WM-DRM Software). If the security of the WM-DRM Software in this device has been compromised, owners of Secure Content (Secure Content Owners) may request that Microsoft revoke the WM-DRM Software's right to acquire new licenses to copy, display and/or play Secure Content. Revocation does not alter the WM-DRM Software's ability to play unprotected content. A list of revoked WM-DRM Software is sent to your device whenever you download a license for Secure Content from the Internet or from a PC. Microsoft may, in conjunction with such license, also download revocation list onto your device on behalf of Secure Content Owners.

### About Wireless LAN

#### Wi-Fi®

Wi-Fi Certification assures tested and proven interoperability by the Wi-Fi Alliance, a group certifying interoperability among wireless LAN devices.

#### IEEE 802.11b

This is one wireless LAN standard set by the 802 working group that establishes LAN technology standards at the IEEE (Institute of Electrical and Electronics Engineers) of the United States. It uses the 2.4 GHz band usable freely without a radio frequency license (ISM band), enabling communications at a maximum speed of 11 Mbps.



The value indicated above is the maximum theoretical value for the wireless LAN standard, and does not indicate the actual data transfer rate.

#### IEEE 802.11g

This is another wireless LAN standard set by the 802 working group that establishes LAN technology standards at the IEEE (Institute of Electrical and Electronics Engineers) of the United States, and is compatible with IEEE 802.11b. It also uses the 2.4 GHz band, but enables communications at a maximum speed of 54 Mbps.



The value indicated above is the maximum theoretical value for the wireless LAN standard, and does not indicate the actual data transfer rate.

### Infrastructure Communications

"Infrastructure Communications" refers to networks using wireless LAN access points.

This function can be used to connect to the Internet or a wired LAN via a wireless LAN access point. Wireless LAN access points include wireless broadband routers.

### Ad-hoc Communications

Signal transfer through wireless interconnection of computers is referred to as "ad hoc communications". With such ad hoc communications there is no connection to the Internet. Ad hoc communications are suited for establishing simple temporary networks.

### Network Names (SSID: Security Set Identifier)

When forming wireless LAN networks, groups are formed to prevent interference, data theft, etc. This grouping is done by "SSID" or "Security Set Identifiers". For further security, a WEP key is set and signal transfer is not possible unless the SSID and WEP key match.

### WEP Key (Network Key)

This is key information used for encrypting data when conducting data transfer. On the AVP-A1HDCI, the same WEP key is used for data encryption and decryption, so the same WEP key must be set on both devices in order for communications to be established between them.

## **WPA (Wi-Fi Protected Access)**

This is a security standard established by the Wi-Fi Alliance. In addition to the conventional SSID (network name) and WEP key (network key), it also uses a user identification function and encrypting protocol for stronger security.

## **WPA2 (Wi-Fi Protected Access 2)**

This is a new version of the WPA established by the Wi-Fi Alliance, compatible with more secure AES encryption.

## **WPA-PSK/WPA2-PSK (Pre-shared Key)**

This is a simple authentication system for mutual authentication when a preset character string matches on the wireless LAN access point and client.

## **Passphrase**

This refers to the code key used for WPA-PSK/WPA2-PSK authentication, a WPA authentication method.

## **TKIP (Temporal Key Integrity Protocol)**

This is a network key used for WPA. The encryption algorithm is RC4, the same as for WEP, but the security level is increased by changing the network key used for encryption for each packet.

## **AES (Advanced Encryption Standard)**

This is a next generation standard encryption method replacing the current DES and 3DES, and because of its high security it is expected to be applied widely to wireless LANs in the future. It uses the "Rijndael" algorithm developed by two Belgian cryptographers to divide the data into blocks of fixed lengths and encrypt each block. It supports data lengths of 128, 192 and 256 bits and key lengths of 128, 192 and 256 bits as well, offering extremely high encryption security.





| Video Convert | Input signal |           |         |       | Monitor output (Normally) |               |               |             | Monitor output (when GUI menu displayed) |           |         |       |
|---------------|--------------|-----------|---------|-------|---------------------------|---------------|---------------|-------------|--|-----------|---------|-------|
|               | HDMI         | COMPONENT | S-VIDEO | VIDEO | HDMI                      | COMPONENT     | S-VIDEO       | VIDEO       | HDMI                                     | COMPONENT | S-VIDEO | VIDEO |
| OFF           | ×            | ×         | ×       | ×     | ×                         | ×             | ×             | ×           | ○  | ○         | ○       | ○     |
|               | ×            | ×         | ×       | ○     | ×                         | ×             | ×             | ○ (VIDEO)   | ○  | ○         | ○       | ○     |
|               | ×            | ×         | ○       | ×     | ×                         | ×             | ○ (S-VIDEO)   | ×           | ○  | ○         | ○       | ○     |
|               | ×            | ×         | ○       | ○     | ×                         | ×             | ○ (S-VIDEO)   | ○ (VIDEO)   | ○  | ○         | ○       | ○     |
|               | ×            | ○         | ×       | ×     | ×                         | ○ (COMPONENT) | ×             | ×           | ○  | ○         | ○       | ○     |
|               | ×            | ○         | ×       | ○     | ×                         | ○ (COMPONENT) | ×             | ○ (VIDEO)   | ○  | ○         | ○       | ○     |
|               | ×            | ○         | ○       | ×     | ×                         | ○ (COMPONENT) | ○ (S-VIDEO)   | ×           | ○  | ○         | ○       | ○     |
|               | ×            | ○         | ○       | ○     | ○                         | ×             | ○ (COMPONENT) | ○ (S-VIDEO) | ○ (VIDEO)                                | ○         | ○       | ○     |
|               | ○            | ×         | ×       | ×     | ○ (HDMI)                  | ×             | ×             | ×           | ○ (HDMI)*                                | ×         | ×       | ×     |
|               | ○            | ×         | ×       | ○     | ○ (HDMI)                  | ×             | ×             | ○ (VIDEO)   | ○ (HDMI)*                                | ×         | ×       | ×     |
|               | ○            | ×         | ○       | ×     | ○ (HDMI)                  | ×             | ○ (S-VIDEO)   | ×           | ○ (HDMI)*                                | ×         | ×       | ×     |
|               | ○            | ×         | ○       | ○     | ○ (HDMI)                  | ×             | ○ (S-VIDEO)   | ○ (VIDEO)   | ○ (HDMI)*                                | ×         | ×       | ×     |
|               | ○            | ○         | ×       | ×     | ○ (HDMI)                  | ○ (COMPONENT) | ×             | ×           | ○ (HDMI)*                                | ×         | ×       | ×     |
|               | ○            | ○         | ×       | ○     | ○ (HDMI)                  | ○ (COMPONENT) | ×             | ○ (VIDEO)   | ○ (HDMI)*                                | ×         | ×       | ×     |
|               | ○            | ○         | ○       | ×     | ○ (HDMI)                  | ○ (COMPONENT) | ○ (S-VIDEO)   | ×           | ○ (HDMI)*                                | ×         | ×       | ×     |
|               | ○            | ○         | ○       | ○     | ○ (HDMI)                  | ○ (COMPONENT) | ○ (S-VIDEO)   | ○ (VIDEO)   | ○ (HDMI)*                                | ×         | ×       | ×     |

○ : Signal present  
× : No signal

○ : Output present  
× : No output  
\* : Superimposed over video signal

 To display the GUI menu on an HDMI monitor, output with a resolution of 480p/576p.

### ☐ ZONE2

| Video Convert   | Input signal    |         |                 | Monitor output  |               |               |
|-----------------|-----------------|---------|-----------------|-----------------|---------------|---------------|
|                 | COMPONENT       | S-VIDEO | VIDEO           | COMPONENT       | S-VIDEO       | VIDEO         |
| ON              | ×               | ×       | ×               | ×               | ×             | ×             |
|                 | ×               | ×       | ○               | ○ (VIDEO)       | ○ (VIDEO)     | ○ (VIDEO)     |
|                 | ×               | ○       | ×               | ○ (S-VIDEO)     | ○ (S-VIDEO)   | ○ (S-VIDEO)   |
|                 | ×               | ○       | ○               | ○ (S-VIDEO)     | ○ (S-VIDEO)   | ○ (S-VIDEO)   |
|                 | ○ (1080p)       | ×       | ×               | ○ (COMPONENT)   | ×             | ×             |
|                 | ○ (480p ~ 720p) | ×       | ×               | ○ (COMPONENT)   | ×             | ×             |
|                 | ○ (480i / 576i) | ×       | ×               | ○ (COMPONENT)   | ○ (COMPONENT) | ○ (COMPONENT) |
|                 | ○ (1080p)       | ×       | ○               | ○ (COMPONENT)*1 | ○ (VIDEO)     | ○ (VIDEO)     |
|                 | ○ (480p ~ 720p) | ×       | ○               | ○ (COMPONENT)*1 | ○ (VIDEO)     | ○ (VIDEO)     |
|                 | ○ (480i / 576i) | ×       | ○               | ○ (COMPONENT)*1 | ○ (COMPONENT) | ○ (VIDEO)     |
|                 | ○ (1080p)       | ○       | ×               | ○ (COMPONENT)*2 | ○ (S-VIDEO)   | ○ (S-VIDEO)   |
|                 | ○ (480p ~ 720p) | ○       | ×               | ○ (COMPONENT)*2 | ○ (S-VIDEO)   | ○ (S-VIDEO)   |
|                 | ○ (480i / 576i) | ○       | ×               | ○ (COMPONENT)*2 | ○ (S-VIDEO)   | ○ (S-VIDEO)   |
|                 | ○ (1080p)       | ○       | ○               | ○ (COMPONENT)*2 | ○ (S-VIDEO)   | ○ (S-VIDEO)   |
|                 | ○ (480p ~ 720p) | ○       | ○               | ○ (COMPONENT)*2 | ○ (S-VIDEO)   | ○ (S-VIDEO)   |
| ○ (480i / 576i) | ○               | ○       | ○ (COMPONENT)*2 | ○ (S-VIDEO)     | ○ (S-VIDEO)   |               |

○ : Output present  
× : No output  
\*1 : With On-screen display, the VIDEO signal is superimposed output.  
\*2 : With On-screen display, the S-VIDEO signal is superimposed output.  
COMPONENT :  
When you operate the **MENU** button, on-screen display is displayed.

| Video Convert | S-VIDEO<br>Monitor Out | Input signal |         |                 | Monitor output  |             |             |
|---------------|------------------------|--------------|---------|-----------------|-----------------|-------------|-------------|
|               |                        | COMPONENT    | S-VIDEO | VIDEO           | COMPONENT       | S-VIDEO     | VIDEO       |
| OFF           | -                      | ×            | ×       | ×               | ×               | ×           | ×           |
|               | -                      | ×            | ×       | ○               | ×               | ×           | ○ (VIDEO)   |
|               | -                      | ×            | ○       | ×               | ×               | ○ (S-VIDEO) | ×           |
|               | Used                   | ×            | ○       | ○               | ×               | ○ (S-VIDEO) | ○ (VIDEO)*2 |
|               | Not used               | ×            | ○       | ○               | ×               | -           | ○ (VIDEO)   |
|               | -                      | ○            | ×       | ×               | ○ (COMPONENT)   | ×           | ×           |
|               | -                      | ○            | ×       | ○               | ○ (COMPONENT)*1 | ×           | ○ (VIDEO)   |
|               | -                      | ○            | ○       | ×               | ○ (COMPONENT)*2 | ○ (S-VIDEO) | ×           |
|               | Used                   | ○            | ○       | ○               | ○ (COMPONENT)*2 | ○ (S-VIDEO) | ○ (VIDEO)*2 |
| Not used      | ○                      | ○            | ○       | ○ (COMPONENT)*1 | -               | ○ (VIDEO)   |             |

○ : Output present

× : No output

\*1 : With On-screen display, the VIDEO signal is superimposed output.

\*2 : With On-screen display, the S-VIDEO signal is superimposed output.

### □ ZONE3

| Input signal |       | Monitor output |
|--------------|-------|----------------|
| S-VIDEO      | VIDEO | VIDEO          |
| ×            | ×     | ×              |
| ×            | ○     | ○ (VIDEO)      |
| ○            | ×     | ○ (S-VIDEO)    |
| ○            | ○     | ○ (S-VIDEO)    |

○ : Signal present

× : No signal

○ : Output present

× : No output

# Troubleshooting

If a problem should arise, first check the following:

1. Are the connections correct?
2. Is the set being operated as described in the owner's manual?
3. Are the other components operating properly?

If this unit does not operate properly, check the items listed in the table below. Should the problem persist, there may be a malfunction.

In this case, disconnect the power immediately and contact your store of purchase.

## [General]

| Symptom   | Cause   | Countermeasure   | Page  |
|---|---|--|---|
| Power does not turn on, or turns off directly after it was turned on.                   | <ul style="list-style-type: none"> <li>• Connection of the power cord is faulty.</li> </ul>                                       | <ul style="list-style-type: none"> <li>• Check that the power plug is securely inserted into the AVP-A1HDCI's AC inlet and the wall power outlet.</li> </ul> | 23  |
| No sound is produced from speakers.   | <ul style="list-style-type: none"> <li>• The connection with the input devices or power amp is faulty.</li> </ul>                 | <ul style="list-style-type: none"> <li>• Check the connections.</li> </ul>   | 11  |
|   | <ul style="list-style-type: none"> <li>• Device you want to play and set input source do not match.</li> </ul>                    | <ul style="list-style-type: none"> <li>• Select an appropriate input source.</li> </ul>  | 45  |
|   | <ul style="list-style-type: none"> <li>• Master volume is turned too low.</li> </ul>  | <ul style="list-style-type: none"> <li>• Adjust the master volume to an appropriate level.</li> </ul>  | 58  |
|   | <ul style="list-style-type: none"> <li>• Mute mode is set.</li> </ul>   | <ul style="list-style-type: none"> <li>• Cancel the mute mode.</li> </ul>  | 58  |
|   | <ul style="list-style-type: none"> <li>• Headphones are connected.</li> </ul>   | <ul style="list-style-type: none"> <li>• Disconnect the headphones.</li> </ul>   | 58  |
| <ul style="list-style-type: none"> <li>• No digital signals are being input.</li> </ul> | <ul style="list-style-type: none"> <li>• Select an input source for which the digital input setting has been made.</li> </ul>     | <ul style="list-style-type: none"> <li>• Select an input source for which the digital input setting has been made.</li> </ul>                                | 45, 48  |
|   |   | <ul style="list-style-type: none"> <li>• The connectors to which the digital inputs are assigned and the settable input modes do not match.</li> </ul>       | <ul style="list-style-type: none"> <li>• Set the input mode.</li> </ul> |
| Display is off.   | <ul style="list-style-type: none"> <li>• The "Dimmer" setting is set to "OFF".</li> <li>• The PURE DIRECT mode is set.</li> </ul> | <ul style="list-style-type: none"> <li>• Set to something other than "OFF".</li> </ul>   | 43  |
|   |   | <ul style="list-style-type: none"> <li>• Set a surround mode other than the PURE DIRECT mode.</li> </ul>   | 52  |
| "DOLBY DIGITAL" indicator does not appear on display.                                   | <ul style="list-style-type: none"> <li>• DVD player's digital audio output setting is not proper.</li> </ul>                      | <ul style="list-style-type: none"> <li>• Check the DVD player's audio output setting. For details, read the DVD player's operating instructions.</li> </ul>  | -   |

| Symptom   | Cause   | Countermeasure   | Page |
|---|---|--|------|
| Power turns off suddenly and power indicator flashes red. | <ul style="list-style-type: none"> <li>• Set is damaged.</li> </ul> | <ul style="list-style-type: none"> <li>• Turn off the power and contact a DENON service center.</li> </ul> | -    |

## [Remote Control Unit]

| Symptom  | Cause   | Countermeasure   | Page |
|--|---|--|------|
| Set does not work properly when remote control unit operated.  | <ul style="list-style-type: none"> <li>• Batteries are worn.</li> </ul>   | <ul style="list-style-type: none"> <li>• Replace with new batteries.</li> </ul>  | 3, 4 |
|  | <ul style="list-style-type: none"> <li>• You are operating outside of the specified range.</li> </ul>   | <ul style="list-style-type: none"> <li>• Operate within the specified range.</li> </ul>  | 4    |
|  | <ul style="list-style-type: none"> <li>• Obstacle between main unit and remote control unit.</li> </ul>   | <ul style="list-style-type: none"> <li>• Remove the obstacle.</li> </ul>   | -    |
|  | <ul style="list-style-type: none"> <li>• The batteries are not inserted in the proper direction, as indicated by the polarity marks in the battery compartment.</li> </ul>    | <ul style="list-style-type: none"> <li>• Insert the batteries in the proper direction, following the polarity marks in the battery compartment.</li> </ul> | 3, 4 |
|  | <ul style="list-style-type: none"> <li>• The set's remote control sensor is exposed to strong light (direct sunlight, inverter type fluorescent bulb light, etc.).</li> </ul> | <ul style="list-style-type: none"> <li>• Move the set to a place in which the remote control sensor will not be exposed to strong light.</li> </ul>        | 4    |
| <ul style="list-style-type: none"> <li>• The remote ID of the main unit and remote control unit do not match.</li> </ul> | <ul style="list-style-type: none"> <li>• Set the same remote IDs for the main unit and remote control unit.</li> </ul>  | 43, 80, 85   |      |

**[Audio]**

| Symptom   | Cause   | Countermeasure   | Page               |
|---|---|--|--------------------|
| No sound is produced from center speaker.   | <ul style="list-style-type: none"> <li>You are playing a monaural source (TV, AM radio broadcast, etc.) in the "STANDARD" (Dolby/DTS Surround) or "HOME THX CINEMA" mode.</li> </ul>  | <ul style="list-style-type: none"> <li>The mode is set to something other than "STANDARD" (Dolby/DTS Surround) or "HOME THX CINEMA" .</li> </ul>   | 50                 |
| No sound is produced from surround speakers.  | <ul style="list-style-type: none"> <li>The surround mode is set to "STEREO", "DIRECT" or "PURE DIRECT".</li> </ul>  | <ul style="list-style-type: none"> <li>Set to a surround playback mode.</li> </ul>   | 50 ~ 52            |
| No sound is produced from surround back speaker.  | <ul style="list-style-type: none"> <li>Surround back speaker setting is set to "None".</li> <li>Surround mode not set to a mode for 6.1- or 7.1-channel playback.</li> </ul>  | <ul style="list-style-type: none"> <li>Set to something other than "None".</li> <li>Select a surround playback mode.</li> </ul>  | 29<br>50 ~ 52      |
| No sound is produced from subwoofer.  | <ul style="list-style-type: none"> <li>Subwoofer's power not turned on.</li> <li>The "Subwoofer" setting at "Speaker configuration" is set to "No".</li> <li>The subwoofer is not properly connected.</li> <li>The subwoofer's volume is turned off.</li> </ul> | <ul style="list-style-type: none"> <li>Turn on the subwoofer's power.</li> <li>Set to "Yes".</li> <li>Check the connections.</li> <li>Adjust the subwoofer's volume to an appropriate level.</li> </ul>              | -<br>29<br>11<br>- |
| No test tones are produced when main remote control unit's <b>TEST</b> button is pressed. | <ul style="list-style-type: none"> <li>Surround mode not set to "STANDARD" (Dolby/DTS Surround) or "HOME THX CINEMA" mode.</li> </ul>   | <ul style="list-style-type: none"> <li>Set to the "STANDARD" (Dolby/DTS Surround) or "HOME THX CINEMA" mode.</li> </ul>  | 50                 |
| DTS sound is not output.  | <ul style="list-style-type: none"> <li>DVD player's audio output setting is not set to bitstream.</li> <li>DVD player is not compatible with DTS sound playback.</li> <li>The AVP-A1HDCI's "Decode Mode" setting is set to "PCM".</li> </ul>                    | <ul style="list-style-type: none"> <li>Set the DVD player. For details, refer to the DVD player's operating instructions.</li> <li>Use a DTS-compatible player.</li> <li>Set to the "Auto" or "DTS" mode.</li> </ul> | -<br>-<br>47       |
| HDMI audio signals are not output from speakers.  | <ul style="list-style-type: none"> <li>The "Manual Setup" – "HDMI Setup" – "Audio" setting is set to "TV".</li> </ul>   | <ul style="list-style-type: none"> <li>Set to "Amp".</li> </ul>  | 32                 |

| Symptom  | Cause  | Countermeasure   | Page |
|--|--|--|------|
| No sound is output from the monitor connected with HDMI connections. | <ul style="list-style-type: none"> <li>The "Manual Setup" – "HDMI Setup" – "Audio" setting is set to "Amp".</li> </ul> | <ul style="list-style-type: none"> <li>Set to "TV".</li> </ul> | 32   |

**[Video]**

| Symptom                                   | Cause   | Countermeasure   | Page                       |
|---|---|--|----------------------------|
| The on-screen display does not appear.    | <ul style="list-style-type: none"> <li>The format of the GUI and TV (NTSC or PAL) do not match.</li> </ul>  | <ul style="list-style-type: none"> <li>Match the format of the GUI and TV.</li> </ul>  | 41                         |
| No picture appears.                       | <ul style="list-style-type: none"> <li>The connections between the AVP-A1HDCI and monitor are faulty.</li> <li>The monitor's input setting is wrong.</li> <li>PURE DIRECT mode is set.</li> <li>The player is connected using the component input connectors, the monitor is connected using the video (yellow) or S-Video output connectors.</li> </ul>  | <ul style="list-style-type: none"> <li>Check the connections.</li> <li>Set properly.</li> <li>Cancel the PURE DIRECT mode.</li> <li>High definition (1080i/720p) and progressive (480p/576p) video signals are not down-converted. Set the player to interlace (480i/576i) signals.</li> </ul>               | 12, 13<br>-<br>52<br>-     |
| No picture appears with HDMI connections. | <ul style="list-style-type: none"> <li>The connections to the HDMI connectors are faulty.</li> <li>HDMI input setting is improper.</li> <li>The monitor is not compatible with copyright protection (HDCP).</li> <li>The HDMI format of the player and monitor do not match.</li> <li>Depending on the monitor you have connected, the display may not be correct when you set to "Auto (Dual)".</li> </ul> | <ul style="list-style-type: none"> <li>Check the connections.</li> <li>Check the HDMI input setting.</li> <li>Connect a monitor that is compatible with copyright protection (HDCP).</li> <li>Match the HDMI format of the player and monitor.</li> <li>Set to either "Monitor 1" or "Monitor 2".</li> </ul> | 12<br>48<br>12<br>12<br>32 |
| Picture cannot be recorded.               | <ul style="list-style-type: none"> <li>Input source does not match recorder's video connection connector (video or S-Video).</li> </ul>   | <ul style="list-style-type: none"> <li>The video conversion function does not work for the REC OUT connectors. Match the input source and recorder connections.</li> </ul>   | 16, 17                     |
| DVDs cannot be copied on a VCR.           | -   | <ul style="list-style-type: none"> <li>This is not a malfunction. Most movie software includes copy prevention signals and cannot be copied.</li> </ul>  | -                          |

**[iPod]**

| Symptom                | Cause   | Countermeasure   | Page |
|------------------------|---|--|------|
| iPod cannot be played. | <ul style="list-style-type: none"> <li>The input source assigned to "iPod dock" is not selected.</li> <li>Cable is not properly connected.</li> <li>Control Dock for iPod's AC adapter is not connected to power outlet.</li> </ul> | Switch to the input source assigned at "iPod dock".              | 49   |
|                        |   | Reconnect.   | 14   |
|                        |   | Plug the Control Dock for iPod's AC adapter into a power outlet. | -    |

**[NET/USB / Rhapsody]**

| Symptom  | Cause   | Countermeasure   | Page |
|--|---|--|------|
| When a USB memory device is connected, "USB" is not displayed on the GUI menu. | <ul style="list-style-type: none"> <li>The set cannot recognize a USB memory device.</li> <li>A USB memory device not conforming to mass storage class or MTP standards is connected.</li> <li>The set port and the connected port do not match.</li> <li>A USB memory device that the set cannot recognize is connected.</li> <li>USB memory device is connected via USB hub.</li> </ul> | Check the connection.  | 19   |
|  |   | Connect a USB memory device conforming to mass storage class or MTP standards.                                 | -    |
|  |   | Connect to the port set at "USB Select".   | 49   |
|  |   | This is not a malfunction. DENON does not guarantee that all USB memory devices will operate or receive power. | -    |
| Files on a USB memory device cannot be played.                                 | <ul style="list-style-type: none"> <li>USB memory device is in format other than FAT16 or FAT32.</li> <li>USB memory device is divided into multiple partitions.</li> <li>Files are stored in a non-compatible format.</li> <li>You are attempting to play a file that is copyright protected.</li> </ul>   | Connect the USB memory device directly to the USB port.  | -    |
|  |   | Set the format to FAT16 or FAT32. For details, refer to the USB memory device's operating instructions.        | -    |
|  |   | When divided into multiple partitions, only files stored in the top partition can be played.                   | 66   |
|  |   | Record the files in a compatible format.   | 66   |
| The file names are not displayed properly (".", etc.).                         | <ul style="list-style-type: none"> <li>Characters that cannot be displayed are used.</li> </ul>   | Files that are copyright protected cannot be played on this set.   | -    |
|  |   | This is not a malfunction. On this set, characters that cannot be displayed are replaced with a ". (period)".  | -    |

| Symptom  | Cause   | Countermeasure  | Page |
|--|---|---|------|
| Internet radio cannot be played.   | <ul style="list-style-type: none"> <li>Ethernet cable is not properly connected or network is disconnected.</li> <li>Program is being broadcast in non-compatible format.</li> <li>The computer's or router's firewall is activated.</li> <li>Radio station is not currently broadcasting.</li> <li>IP address is wrong.</li> </ul> | Check the connection status.  | 21   |
|  |   | Only Internet radio programs in MP3 and WMA can be played on this set.  | 66   |
|  |   | Check the computer's or router's firewall settings.   | -    |
|  |   | Choose a radio station that is currently broadcasting.  | 68   |
| Files stored on a computer cannot be played.   | <ul style="list-style-type: none"> <li>Files are stored in a non-compatible format.</li> <li>You are attempting to play a file that is copyright protected.</li> <li>Set and computer are connected by USB cable.</li> </ul>  | Check the set's IP address.   | 38   |
|  |   | Record in a compatible format.  | 66   |
| Server is not found, or it is not possible to connect to the server.   | <ul style="list-style-type: none"> <li>The computer's or router's firewall is activated.</li> <li>Computer's power is not turned on.</li> <li>Server is not running.</li> <li>Set's IP address is wrong.</li> </ul>   | Files that are copyright protected cannot be played on this set.  | 66   |
|  |   | The set's USB port cannot be used for connection to a computer.   | -    |
|  |   | Check the computer's or router's firewall settings.   | -    |
|  |   | Turn on the power.  | -    |
| Cannot connect to preset or favorite radio stations.   | <ul style="list-style-type: none"> <li>Radio station is not currently broadcasting.</li> <li>Radio station is not currently in service.</li> </ul>  | Launch the server.  | 38   |
|  |   | Check the set's IP address.   | -    |
| For some radio stations, "Server Full" or "Connection Down" is displayed and station cannot be connected to. | <ul style="list-style-type: none"> <li>Station is congested or not currently broadcasting.</li> </ul>   | Wait a while before trying again.   | -    |
|  |   | It is not possible to connect to radio stations that are no longer in service.  | -    |
| Sound is broken during playback.   | <ul style="list-style-type: none"> <li>Network's signal transfer speed is slow or communications lines or radio station is congested.</li> </ul>  | Wait a while before trying again.   | -    |
| Sound quality is poor or played sound is noisy.  | <ul style="list-style-type: none"> <li>File being played has a low bit rate.</li> </ul>   | This is not a malfunction. When playing broadcast data with a high bit rate, the sound may be broken, depending on the communications conditions. | -    |



| Symptom  | Cause   | Countermeasure  | Page         |
|--|---|---|--------------|
| Cannot login to Rhapsody. ("Username or Password is incorrect" is displayed) | <ul style="list-style-type: none"> <li>Login information is incorrect.</li> <li>Trial period has expired.</li> </ul>  | <ul style="list-style-type: none"> <li>Check if the Username for Rhapsody has been properly entered.</li> </ul>   | 38           |
|  |   | <ul style="list-style-type: none"> <li>Re-enter the Password. (Password is not displayed.)</li> <li>Get a full account.<br/><a href="http://www.rhapsody.com/denon/signup">www.rhapsody.com/denon/signup</a></li> </ul>     | 38<br>66, 70 |
| Cannot play.   | <ul style="list-style-type: none"> <li>When the trial period has finished, there is a limit to the playing time and number of tracks that can be played.</li> </ul> | <ul style="list-style-type: none"> <li>Get a full account.<br/><a href="http://www.rhapsody.com/denon/signup">www.rhapsody.com/denon/signup</a></li> </ul>  | 66, 70       |
| Stops in the middle of playing.  | <ul style="list-style-type: none"> <li>When the trial period has finished, there is a limit to the playing time and number of tracks that can be played.</li> </ul> | <ul style="list-style-type: none"> <li>Get a full account.</li> </ul>   | 66, 70       |
| Cannot compile Playlist.   | <ul style="list-style-type: none"> <li>The AVP-A1HDCI does not respond to playlist compilation.</li> </ul>  | <ul style="list-style-type: none"> <li>When the playlist is compiled in "PC Application", it is registered to "My Library". In this way, the playlist can be played in AVP-A1HDCI.</li> <li>※ Need full account.</li> </ul> | –            |
| Cannot delete Rhapsody Channel registered in "My Channels".                  | <ul style="list-style-type: none"> <li>Cannot be done with AVP-A1HDCI.</li> </ul>   | <ul style="list-style-type: none"> <li>Delete from "PC Application".</li> </ul>   | –            |
| Cannot delete Tracks, Playlists, Channels registered in "My Library".        | <ul style="list-style-type: none"> <li>Cannot be done with AVP-A1HDCI.</li> </ul>   | <ul style="list-style-type: none"> <li>Delete from "PC Application".</li> <li>※ Need full account.</li> </ul>   | –            |

#### [Wireless LAN]

| Symptom  | Cause  | Countermeasure   | Page    |
|--|--|--|---------|
| Cannot connect to network.                             | <ul style="list-style-type: none"> <li>The settings of the SSID and network key (WEP) are incorrect.</li> <li>The reception is poor and the signals cannot be received.</li> </ul> | <ul style="list-style-type: none"> <li>Match the network settings with the AVP-A1HDCI's settings.</li> </ul>   | 35 ~ 38 |
|  |  | <ul style="list-style-type: none"> <li>Shorten the distance from the wireless LAN's access point, remove any obstacles and otherwise improve visibility, then try reconnecting. Also install away from microwave ovens and the access points of other networks.</li> </ul> | –       |
| Played sound is interrupted or sound cannot be played. | <ul style="list-style-type: none"> <li>There are multiple networks and the usable channels overlap.</li> </ul>   | <ul style="list-style-type: none"> <li>Set the access point's channel settings away from the channels used for other networks. Alternatively, connect using a network cable.</li> </ul>  | –       |
|  |  | <ul style="list-style-type: none"> <li>Set the access point's channel settings away from the channels used for other networks. Alternatively, connect using a network cable.</li> </ul>  | –       |

#### [XM Satellite Radio]

| Symptom                        | Cause  | Countermeasure   | Page |
|--------------------------------|--|--|------|
| "CHECK XM TUNER" is displayed. | <ul style="list-style-type: none"> <li>The XM Mini-Tuner is not installed or not fully seated in the XM Mini-Tuner Dock or the XM Mini-Tuner dock is not connected to the AVP-A1HDCI.</li> </ul> | <ul style="list-style-type: none"> <li>Confirm the XM Mini-Tuner is fully seated in the dock and check the XM Mini-Tuner dock cable is connected to the AVP-A1HDCI.</li> </ul> | 19   |
| "CHECK ANTENNA" is displayed.  | <ul style="list-style-type: none"> <li>AVP-A1HDCI's XM connector and the XM Mini-Tuner and Home Dock is not properly connected.</li> </ul>   | <ul style="list-style-type: none"> <li>Check that the connections are correct.</li> </ul>  | 19   |

**[XM Satellite Radio]**

| Symptom                             | Cause   | Countermeasure   | Page |
|-------------------------------------|---|--|------|
| "NO SIGNAL" is displayed.           | <ul style="list-style-type: none"> <li>The signal cannot be received.</li> </ul>  | <ul style="list-style-type: none"> <li>Reposition your XM Mini-Tuner and Home Dock antenna.</li> </ul>   | –    |
| "OFF AIR" is displayed.             | <ul style="list-style-type: none"> <li>The selected channel is not currently broadcasting.</li> </ul>   | <ul style="list-style-type: none"> <li>Select another channel.</li> </ul>  | –    |
| Receiving only XM channels 0 and 1. | <ul style="list-style-type: none"> <li>The XM Mini-Tuner is not activated.</li> </ul>   | <ul style="list-style-type: none"> <li>Contact XM Radio.</li> </ul>  | –    |
| "XM ---" is displayed.              | <ul style="list-style-type: none"> <li>You selected an XM channel that is blocked or cannot be receive with your XM subscription package.</li> </ul>  | <ul style="list-style-type: none"> <li>Consult the latest channel guide at <a href="http://www.xmradio.com">www.xmradio.com</a> or <a href="http://www.xmaradio.ca">www.xmaradio.ca</a> for the current list of channels. For cases of a new radio or a radio that has not received XM's signal for an extended period, allow the radio to receive the XM satellite signal for at least 5 minutes and then try to select the channel again.</li> </ul>             | –    |
| "UPDATING" is displayed.            | <ul style="list-style-type: none"> <li>The selected channel is not available. The channel may have been reassigned to a different channel number. This message may occur initially with a new radio or a radio that has not received XM's signal for an extended period.</li> </ul> | <ul style="list-style-type: none"> <li>Consult the latest channel guide at <a href="http://www.xmradio.com">www.xmradio.com</a> or <a href="http://www.xmaradio.ca">www.xmaradio.ca</a> for the current list of channels. For information on receiving this channel, visit <a href="http://www.xmradio.com">www.xmradio.com</a> or <a href="http://www.xmaradio.ca">www.xmaradio.ca</a> contact XM Satellite Radio at 1-800-967-2346 or 1-877-438-9677.</li> </ul> | –    |

# Specifications

## Audio section

- Analog**
  - Input sensitivity / Input impedance:** RCA Pre output (unbalanced) : 200 mV / 47 k $\Omega$ /kohms  
XLR Pre output (balanced) : 400 mV / 100 k $\Omega$ /kohms
  - Frequency response:** 10 Hz ~ 100 kHz +1, -3 dB (DIRECT mode)
  - S/N:** 102 dB (IHF-A weighted, DIRECT mode)
  - Distortion:** 0.005 % (20 Hz ~ 20 kHz) (DIRECT mode)
  - Rated output:** RCA Pre output (unbalanced) : 1.2 V  
XLR Pre output (balanced) : 2.4 V
- Digital**
  - D/A output:** Rated output — 2 V (at 0 dB playback)  
Total harmonic distortion — 0.005 % (1 kHz, at 0 dB)  
Dynamic range — 110 dB  
Format — Digital audio interface
  - Digital input:**
- Phono equalizer (PHONO input – REC OUT)**
  - Input sensitivity:** 2.5 mV
  - RIAA deviation:**  $\pm$ 1 dB (20 Hz to 20 kHz)
  - S/N:** 74 dB (A weighting, with 5 mV input)
  - Rated output:** 150 mV
  - Distortion factor:** 0.03 % (1 kHz, 3 V)

## Video section

- Standard video connectors**
  - Input / output level and impedance:** 1 Vp-p, 75  $\Omega$ /ohms
  - Frequency response:** 5 Hz ~ 10 MHz — +0, -3 dB (when video convert set to “OFF”)
- S-Video connectors**
  - Input / output level and impedance:** Y (brightness) signal — 1 Vp-p, 75  $\Omega$ /ohms  
C (color) signal — 0.286 Vp-p, 75  $\Omega$ /ohms
  - Frequency response:** 5 Hz ~ 10 MHz — +0, -3 dB (when video convert set to “OFF”)
- Color component video connector**
  - Input / output level and impedance:** Y (brightness) signal — 1 Vp-p, 75  $\Omega$ /ohms  
P<sub>B</sub> / C<sub>B</sub> signal — 0.7 Vp-p, 75  $\Omega$ /ohms  
P<sub>R</sub> / C<sub>R</sub> signal — 0.7 Vp-p, 75  $\Omega$ /ohms
  - Frequency response:** 5 Hz ~ 100 MHz — +0, -3 dB (when video convert set to “OFF”)

## Tuner section

|  | [FM]  | [AM]               |
|--|---|--------------------|
| <b>Receiving Range:</b>                      | 87.5 MHz ~ 107.9 MHz  | 520 kHz ~ 1710 kHz |
| <b>Usable Sensitivity:</b>                   | 1.0 $\mu$ V (11.2 dBf)                                      | 19 $\mu$ V         |
| <b>50 dB Quieting Sensitivity:</b>           | MONO 1.6 $\mu$ V (15.3 dBf)<br>STEREO 23 $\mu$ V (38.5 dBf) |                    |
| <b>S/N (IHF-A):</b>                          | MONO 77 dB<br>STEREO 72 dB                                  |                    |
| <b>Total harmonic Distortion (at 1 kHz):</b> | MONO 0.2 %<br>STEREO 0.3 %                                  |                    |

## HD Radio section

|  | [FM]  | [AM]               |
|--|---|--------------------|
|  | (note: $\mu$ V at 75 $\Omega$ /ohms, 0 dBf = 1 x 10 <sup>-15</sup> W) |                    |
| <b>Receiving Range:</b>                      | 87.5 MHz ~ 107.9 MHz  | 530 kHz ~ 1710 kHz |
| <b>Usable Sensitivity:</b>                   | 1.0 $\mu$ V (11.2 dBf)  | 20 $\mu$ V         |
| <b>50 dB Quieting Sensitivity:</b>           | MONO 1.6 $\mu$ V (15.3 dBf)<br>STEREO 23 $\mu$ V (38.5 dBf)           |                    |
| <b>S/N (IHF-A):</b>                          | MONO 77 dB<br>STEREO 72 dB<br>HD 85 dB                                | 85 dB              |
| <b>Total harmonic Distortion (at 1 kHz):</b> | MONO 0.2 %<br>STEREO 0.3 %<br>HD 0.01 %                               | 0.01 %             |

## Wireless LAN

- Network type (wireless LAN standards) :** Conforming to IEEE 802.11b  
Conforming to IEEE 802.11g  
(Conforming to Wi-Fi®)\*
- Transfer rate:** DS-SS: 11 / 5.5 / 2 / 1 Mbps (Automatic switching)  
OFDM: 54 / 48 / 36 / 24 / 18 / 12 / 9 / 6 Mbps (Automatic switching)
- Security:** SSID (Network name)  
WEP key (network key) (64/128 bits)  
WPA-PSK (TKIP/AES)  
WPA2-PSK (TKIP/AES)
- Used frequency range:** 2,412 MHz ~ 2,472 MHz
- No. of channels:** Conforming to IEEE 802.11b : 11 ch (DS-SS) (Of which 1 channel used)  
Conforming to IEEE 802.11g : 11 ch (OFDM) (Of which 1 channel used)

## General

- Power supply:** AC 120 V, 60 Hz
- Power consumption:** 2 A  
0.3 W (Standby)
- Maximum external dimensions:** 434 (W) x 214 (H) x 488 (D) mm (17-3/32" x 8-27/64" x 19-7/32")
- Weight:** 27 kg (Approx 59 lbs 8 oz)

## Main remote control unit (RC-1067)

- Batteries:** LR6/AA Type (two batteries)
- Maximum external dimensions:** 63 (W) x 238 (H) x 31 (D) mm
- Weight:** 190 g (Approx 6.7 oz) (including batteries)

## Sub remote control unit (RC-1070)

- Batteries:** R03/AAA Type (two batteries)
- Maximum external dimensions:** 49 (W) x 220 (H) x 24.5 (D) mm
- Weight:** 114 g (Approx 4 oz) (including batteries)

\* : Wi-Fi® conformity indicates tested and proven interoperability by the “Wi-Fi Alliance”, a group certifying interoperability among wireless LAN devices.

※ For purposes of improvement, specifications and design are subject to change without notice.

## List of preset codes

### Denon Amp

**D** Denon 81001, 82001, 83001, 84001

### Denon Tuner

**D** Denon (Analog) 52863, 52795, 52800, 52805  
Denon (XM Radio) 52864, 52812, 52813, 52814

### Denon Digital Tuner

**D** Denon (NET) 62865, 62837, 62838, 62839  
Denon (HD Radio) 62840, 62841, 62842, 62843

### Denon iPod

**D** Denon 72815, 72816, 72817, 72818

### Cable

**A** A-Mark 00008, 00144  
ABC 00237, 00003, 00008  
Accuphase 00003  
Acom 00237  
Action 00237  
Active 00237  
ADB 01230  
Aichi Denshi 01512  
Americast 00899  
Amstrad 01222  
Archer 00237  
Auna 01230  
Austar 00276  
**B** BCC 00276  
Bell South 00899  
Bestlink 00303  
Birmingham Cable Communications 00276  
British Telecom 00003  
**C** Cable & Wireless 01068  
Century 00008  
Coship 01462  
**D** Daehan 00778  
Daeryung 01877, 00877, 00477, 00008  
Digeo 01187  
Director 00476  
DX Antenna 01500  
**E** Emerson 00303  
Encon 00008  
**F** Fosgate 00276  
Foxtel 01222  
France Telecom 00817

Freebox 01482  
Fujitsu 01497  
**G** Galaxi 00008  
GE 00237, 00144  
Gehua 00476  
General Instrument 00476, 00810, 00276, 00003  
Gibraltar 00003  
GNI 01466  
GoldStar 00144  
**H** Hitachi 00003, 00008  
Hongtian Jiangsu 01462  
Hwalin 00303  
**I** Insight 00476, 00810  
**J** Jerrold 00476, 00810, 00276, 00003  
Jiuzhou 01445  
**K** KNC 00008  
**L** LG 00144  
**M** Macab 00817  
Madritel 01230  
Maspro 01510  
Matav 01082  
Memorex 00000  
Mitsubishi 00003  
Motorola 01376, 00476, 00810, 00276, 01187  
MS 00303  
**N** NEC 01496  
Noos 00817  
Nova Vision 00008  
Novaplex 00008  
NTL 00276, 00003, 01060, 01068  
**O** Oak 00303  
Ono 01068  
Optus 00276, 01060  
**P** Pace 01877, 00877, 00237, 00008, 01060, 01068, 01577  
Panasonic 00000, 00008, 00144, 01488  
Paragon 00000, 00008, 00525  
Penney 00000  
Philips 01305, 00317, 00817  
Pioneer 01877, 00877, 00144, 00533, 01500  
Pulsar 00000  
PVP Stereo Visual Matrix 00003  
**Q** Quasar 00000  
**R** RadioShack 00303  
Regal 00276  
Runco 00000  
**S** Sagem 00817  
Salora 00000  
Samsung 00003, 00000, 00144, 00778, 00840, 01060, 01666

Scientific Atlanta 01877, 00877, 00477, 00237, 00003, 00000, 00008, 01510  
Skyworth 01464  
Sony 01006, 01460  
Sprucer 00144  
Starcom 00003  
StarHub 00276  
Sumitomo 01500, 01504  
Supercable 00276  
**T** Taihan 00778  
TCL 01445  
Telewest 01068  
Time Warner cable 01877  
TongKook 00840  
Torx 00003  
Toshiba 00000, 01509  
Trans PX 00276, 00303  
TS 00003, 00303  
**U** United Cable 00276, 00003  
US Electronics 00276, 00003, 00008  
**V** Videoway 00000  
Visiopass 00817  
**Z** Zenith 00000, 00525, 00899

### Cable/PVR Combination ※1

**A** Americast 00899  
**D** Digeo 01187  
**F** Freebox 01482  
**G** General Instrument 00810  
**J** Jerrold 00810  
**M** Motorola 01376, 00810, 01187  
**P** Pace 01877, 00237  
Pioneer 01877, 00877  
**S** Scientific Atlanta 01877, 00877  
Sony 01006  
Supercable 00276  
**T** Time Warner cable 01877  
**Z** Zenith 00899

### CD Player

**A** Acoustic Research 40420  
Advantage 40032  
Aiwa 40157  
Arcam 40157  
Audio Research 40157  
Audiolab 40157  
Audiomeca 40157  
Audioton 40157  
AVI 40157

**B** Balanced Audio Technology 40157  
Burmester 40420  
Bush 40388  
**C** Cairn 40157  
California Audio Labs 40029, 40303  
Cambridge 40157  
Cambridge Audio 40157  
Cambridge Soundworks 40157  
Carver 40157, 40179  
CDC 40420  
CEC 40420  
Copland 40393  
Curtis Mathes 40032  
Cyrus 40157  
**D** Denon 40873, 40003, 40766, [42867]\*, 42868  
DKK 40000  
DMX Electronics 40157  
Dual 40003  
Dynaco 40157  
Dynamic Bass 40179  
**F** Fisher 40000, 40179  
**G** Garrard 40393, 40420  
Genexxa 40000, 40032, 40037, 40179  
Goldmund 40157  
Grundig 40157  
**H** Hafler 40173  
Harman/Kardon 40100, 40157, 40173  
Hitachi 40032  
**I** Inkel 40157  
Integra 40101  
**J** Jerrold 40003  
JVC 40032, 40072  
**K** Kenwood 40681, 40000, 40029, 40157, 40028, 40037, 40036, 40190  
KLH 41318  
Krell 40157  
**L** Linn 40157  
Loewe 40157  
Luxman 40393  
LXI 40179  
**M** Magnavox 40157  
Marantz 40029, 40157  
Matsui 40157  
MCS 40029  
Memorex 40000, 40032, 40179, 40420, 40468  
Meridian 40157  
Micromega 40157  
Miro 40000  
Mission 40157

Modulaire 40000, 40032, 40087, 40179, 40420, 40468  
MTC 40420  
Musical Fidelity 40393  
Myryad 40157  
**N** NAD 40000, 40721  
Naim 40157  
NSM 40157  
**O** Onkyo 40868, 40101  
Optimus 40000, 40032, 40037, 40087, 40179, 40393, 40420, 40468  
Orion 40393  
**P** Panasonic 40029, 40303, 40388, 40752  
Parasound 40420  
Penney 40029  
Philips 40157  
Pioneer 40032, 40101, 40468  
Polk Audio 40157  
Procead 40420  
Proton 40157  
**Q** QED 40157  
Quad 40157  
Quasar 40029  
**R** Radiola 40157  
RadioShack 40000, 40032, 40179, 40420, 40468  
RCA 40032, 40053, 40179, 40420, 40468  
Realistic 40000, 40032, 40087, 40179, 40420, 40468  
Restek 40157  
Revox 40157  
Roksan 40420  
Rotel 40157, 40420  
Royal 40420  
**S** SAE 40157  
Saisho 40000  
Sansui 40000, 40157  
Sanyo 40000, 40087, 40179  
SAST 40157  
Sears 40179  
Sharp 40037  
Siemens 40157  
Silsonic 40036  
Simaudio 40157  
Sonic Frontiers 40157  
Sony 40490, 40000, 40100, 41364, 40185  
Sugden 40157  
Sylvania 40157  
**T** TAG McLaren 40157  
Tandy 40032  
Tascam 40393, 40420

|          |             |  |
|----------|-------------|--|
| <b>T</b> | Teac        | 40490, 40393, 40420                      |
|          | Technics    | 40029, 40303                             |
|          | Techwood    | 40303                                    |
|          | Thomson     | 40053                                    |
|          | Thorens     | 40157                                    |
|          | Thule Audio | 40157                                    |
|          | Tokai       | 40420                                    |
| <b>U</b> | Universum   | 40157, 40053                             |
| <b>V</b> | Victor      | 40072                                    |
| <b>W</b> | Wadia       | 40393                                    |
|          | Wards       | 40000, 40032, 40157, 40053, 40087, 40179 |
| <b>Y</b> | Yamaha      | 40490, 40868, 40032, 40036               |
|          | Yorx        | 40000                                    |

### CD Recorder

|          |         |                     |
|----------|---------|---------------------|
| <b>D</b> | Denon   | 40766, 42868        |
| <b>J</b> | JVC     | 40072               |
| <b>R</b> | RCA     | 40053, 40420        |
| <b>S</b> | Sony    | 40000, 40100, 41364 |
| <b>T</b> | Teac    | 40420               |
|          | Thomson | 40053               |

### Tape Deck

|          |               |   |
|----------|---------------|---|
| <b>A</b> | Aiwa          | 20029, 20197, 20200, 21315                      |
|          | Akai          | 20283, 20439                                    |
|          | Arcam         | 20076   |
|          | Audiolab      | 20029   |
| <b>C</b> | Carver        | 20029   |
| <b>D</b> | Denon         | 20076, 20371, 21311, [22471]*                   |
| <b>F</b> | Fisher        | 20074   |
| <b>G</b> | Garrard       | 20308, 20309, 20375, 20439                      |
|          | Genexxa       | 20439   |
|          | GoldStar      | 20375   |
|          | Grundig       | 20029, 20375                                    |
| <b>H</b> | Harman/Kardon | 20182, 20029, 21314                             |
| <b>I</b> | Inkel         | 20070, 20071, 20337                             |
| <b>J</b> | JVC           | 20244, 20273, 20274, 20303, 20304, 20310, 21309 |
| <b>K</b> | Kenwood       | 20070, 20071, 20092, 20233, 20234, 21364        |
| <b>L</b> | LG            | 20375   |
|          | Luxman        | 20308, 20309                                    |
| <b>M</b> | Magnavox      | 20029   |
|          | Marantz       | 20029, 20009                                    |
|          | Memorex       | 20099   |
|          | Mitsubishi    | 20283, 20439                                    |
|          | Myryad        | 20029   |
| <b>O</b> | Onkyo         | 20135, 20136, 20282                             |
|          | Optimus       | 20027, 20220, 20337, 20439                      |
|          | Orion         | 20308, 20309                                    |

|          |            |  |
|----------|------------|--|
| <b>P</b> | Palladium  | 20375                                    |
|          | Panasonic  | 20229                                    |
|          | Philips    | 20029, 20229                             |
|          | Phonotrend | 20337                                    |
|          | Pioneer    | 20027, 20220, 20099, 20109, 21306, 21312 |
|          | Polk Audio | 20029                                    |
| <b>R</b> | Radiola    | 20029                                    |
|          | RCA        | 20027, 20220                             |
|          | Revox      | 20029                                    |
| <b>S</b> | Sansui     | 20029, 20009                             |
|          | Sanyo      | 20074                                    |
|          | Sharp      | 20231, 20371                             |
|          | Sherwood   | 20337                                    |
|          | Sonic      | 20375                                    |
|          | Sony       | 20243, 20170, 20291, 20234, 21313        |
| <b>T</b> | TaeKwang   | 20439                                    |
|          | Tandberg   | 20109                                    |
|          | Teac       | 20280, 20283, 20289, 20308, 20309        |
|          | Technics   | 20229                                    |
|          | Technovox  | 20229                                    |
|          | Thorens    | 20029                                    |
| <b>U</b> | Universum  | 20375, 20439                             |
| <b>V</b> | Victor     | 20244, 20273, 20274                      |
| <b>W</b> | Wards      | 20027, 20029                             |
|          | Wharfedale | 20439                                    |
| <b>Y</b> | Yamaha     | 20097, 20094                             |

### HDTV Tuner ※1

|          |                  |              |
|----------|------------------|--------------|
| <b>A</b> | ABS              | 01272        |
|          | Accurian         | 01653        |
|          | Alienware        | 01272        |
| <b>C</b> | CyberPower       | 01272        |
| <b>D</b> | D-Link           | 01554        |
|          | Dgtec            | 01363        |
| <b>E</b> | Epson            | 01563        |
| <b>G</b> | Gateway          | 01272        |
| <b>H</b> | Hewlett Packard  | 01272, 01267 |
|          | Howard Computers | 01272        |
|          | HP               | 01272, 01267 |
|          | Hush             | 01272        |
| <b>I</b> | iBUYPOWER        | 01272        |
| <b>L</b> | LG               | 01415        |
|          | Linksys          | 01272, 01365 |
| <b>M</b> | Media Center PC  | 01272        |
|          | Microsoft        | 01272, 01805 |
|          | Mind             | 01272        |
|          | Motorola         | 01363        |
| <b>N</b> | Niveus Media     | 01272        |
|          | Northgate        | 01272        |

|          |                 |                     |
|----------|-----------------|---------------------|
| <b>P</b> | Packard Bell    | 01272               |
|          | Panasonic       | 01120               |
|          | Pioneer         | 01010               |
| <b>R</b> | Ricavision      | 01272               |
| <b>S</b> | Samsung         | 01190, 01490        |
|          | Sensory Science | 01126               |
|          | Sharp           | 01010               |
|          | SMC             | 01456               |
|          | Sony            | 01272, 01324, 01364 |
|          | Stack 9         | 01272               |
|          | Sylvania        | 01563               |
|          | Systemax        | 01272               |
| <b>T</b> | Tagar Systems   | 01272               |
|          | Toshiba         | 01272               |
|          | Touch           | 01272               |
| <b>V</b> | Viewsonic       | 01272, 01329        |
|          | Vizio           | 01126               |
|          | Voodoo          | 01272               |
| <b>X</b> | Xbox            | 01805               |
| <b>Z</b> | ZT Group        | 01272               |

### Satellite Receiver

|          |            |  |
|----------|------------|--|
| <b>A</b> | @sat       | 01300  |
|          | @Sky       | 01334  |
|          | A-Mark     | 00345  |
|          | ABsat      | 00123, 00713   |
|          | ADB        | 00642, 01259, 01367, 01418, 01473, 01491                             |
|          | AGS        | 00710  |
|          | Aiwa       | 01514  |
|          | Akai       | 00200  |
|          | Alba       | 00455, 00713, 01284, 01659, 01811                                    |
|          | Allsat     | 00200, 01043   |
|          | Alltech    | 00713  |
|          | Allvision  | 01232, 01334, 01412  |
|          | AlphaStar  | 00772  |
|          | Amitronica | 00713  |
|          | Amstrad    | 00345, 00713, 00795, 00847, 00863, 00882, 01113, 01175, 01693, 01801 |
|          | Anglo      | 00713  |
|          | Ankaro     | 00713  |
|          | AntSat     | 01083  |
|          | Apollo     | 00455  |
|          | Arcon      | 01043, 01075   |
|          | Armstrong  | 00200  |
|          | Arnion     | 01300  |
|          | Asat       | 00200  |
|          | ASCI       | 01334  |
|          | ASLF       | 00713  |
|          | AssCom     | 00853  |
|          | Astacom    | 00710  |

|          |                          |  |
|----------|--------------------------|--|
|          | Aston                    | 00142                                    |
|          | Astra                    | 00713                                    |
|          | Astratec                 | 01743                                    |
|          | Astro                    | 00173, 00658, 01099, 01100, 01113        |
|          | Atlantic Telephone       | 01333                                    |
|          | Atsat                    | 01300                                    |
|          | AtSky                    | 01334                                    |
|          | Audioline                | 01672                                    |
|          | Aurora                   | 00642, 00879, 01333, 01433               |
|          | Austar                   | 00497, 00642, 00863, 00879, 01176, 01259 |
|          | Axiel                    | 00710                                    |
|          | Axil                     | 01457, 01659                             |
|          | Axis                     | 01111                                    |
| <b>B</b> | B@ytronic                | 01412                                    |
|          | Beko                     | 00455                                    |
|          | Bell ExpressVu           | 00775                                    |
|          | Big Sat                  | 01457                                    |
|          | Black Diamond            | 01284                                    |
|          | Blaupunkt                | 00173                                    |
|          | Blue Sky                 | 00713                                    |
|          | Boca                     | 00713, 01232, 01366                      |
|          | Boston                   | 00710, 01251                             |
|          | Brainwave                | 00658, 01672                             |
|          | British Sky Broadcasting | 00847, 01175, 01662, 01847               |
|          | Broco                    | 00713                                    |
|          | BskyB                    | 00847, 01175, 01662                      |
|          | BT                       | 00710, 01296                             |
|          | Bubu Sat                 | 00713                                    |
|          | Bush                     | 01284, 01645, 01672, 01743, 01811        |
| <b>C</b> | Canal                    | 00853                                    |
|          | Canal Digital            | 00853, 01622                             |
|          | Canal Satellite          | 00853, 01339, 01853                      |
|          | Canal+                   | 00853                                    |
|          | Centrex                  | 01457                                    |
|          | CGV                      | 01413, 01567                             |
|          | Chaparral                | 00216                                    |
|          | Cherokee                 | 00123, 00710                             |
|          | Chess                    | 00713, 01085, 01334, 01626               |
|          | Chili                    | 01718                                    |
|          | CityCom                  | 00299, 00394, 00818, 01075, 01176, 01232 |
|          | Classic                  | 01672                                    |
|          | Clatronic                | 01413                                    |
|          | CNS                      | 01367                                    |
|          | Comag                    | 01232, 01366, 01412, 01413               |
|          | Condor                   | 01700                                    |
|          | Conia                    | 01695                                    |
|          | Contec                   | 00394                                    |
|          | Continental Edison       | 01695                                    |
|          | Coship                   | 01457                                    |

|          |                     |   |
|----------|---------------------|---|
|          | Crossdigital        | 01109   |
|          | Crown               | 01284   |
|          | Cryptovision        | 00455, 00795  |
|          | Cyfra+              | 01076   |
|          | Cyrus               | 00200   |
| <b>D</b> | D-box               | 00723, 00873, 01114   |
|          | Daewoo              | 00713, 01111, 01296, 01743  |
|          | Delfa               | 00863   |
|          | Deltasat            | 01075   |
|          | Dgtec               | 01542, 01631, 01242   |
|          | Digenius            | 00299   |
|          | Digitality          | 01685   |
|          | Digifusion          | 01645, 01743  |
|          | DigiLogic           | 01284   |
|          | DigiQuest           | 00863, 01300, 01457, 01473  |
|          | DigiSat             | 01232   |
|          | Digisky             | 01457   |
|          | DigitAll World      | 01227   |
|          | Digiturk            | 01076   |
|          | Digiwave            | 01631   |
|          | Dijam               | 01296   |
|          | DiPro               | 01367, 01543  |
|          |                     | 01377, 00392, 00566, 00639, 01639, 01142, 00247, 00749, 01749, 00724, 00819, 01856, 01076, 01108, 00099, 01109, 01414, 01442, 01609, 01392, 01640 |
|          | DiracTV             |   |
|          | Discovery           | 00710   |
|          | Dish Network System | 01505, 01005, 00775, 01775  |
|          | Dishpro             | 01505, 01005, 00775, 01775  |
|          | Distratel           | 01283, 01704  |
|          | DMT                 | 01075   |
|          | DNT                 | 00200   |
|          | Dream Multimedia    | 01237   |
|          | DSE                 | 01375   |
|          | DSTV                | 00642, 00879, 01433   |
|          | Durabrand           | 01284   |
|          | DX Antenna          | 01530   |
|          |                     | 01505, 01005, 00775, 00455, 00610, 00713, 00853, 00871, 01086, 01200, 01323, 01409, 01418, 01473, 01775   |
| <b>E</b> | Echostar            | 00713   |
|          | Einhell             | 00713   |
|          | Elap                | 00713, 01567  |
|          | Elsat               | 00713   |
|          | Elta                | 00200, 01659  |
|          | Emme Esse           | 00871   |
|          | Energy Sistem       | 01631   |
|          | Engel               | 00713, 01251  |
|          | EP Sat              | 00455   |
|          | Esat                | 00879   |
|          | Eurieult            | 00882   |

|                    |   |
|--------------------|---|
| Eurocrypt          | 00455   |
| EuroLine           | 01251   |
| Europa             | 00863   |
| Europhon           | 00299   |
| Eurosky            | 00262, 00299                                    |
| Eurostar           | 00818   |
| Eutelsat           | 00713   |
| Expressvu          | 00775, 01775                                    |
| <b>F</b> Fenner    | 00713   |
| Ferguson           | 00455, 01291, 01743                             |
| Finlandia          | 00455   |
| Finlux             | 00455   |
| Flair Mate         | 00713   |
| FMD                | 01251, 01413, 01457                             |
| Force              | 01101   |
| Fortec Star        | 01083   |
| Foxtel             | 00455, 00497, 00795, 00879, 01162, 01176, 01356 |
| Fracapro Planet    | 00871   |
| Fracarro           | 00125, 00871                                    |
| France Telecom     | 00871   |
| Freesat            | 00882   |
| FTE                | 00863   |
| FTEmaximal         | 00713, 00863                                    |
| Fuba               | 00173, 00262, 00299, 00394, 01214, 01251, 01801 |
| Fugionkyo          | 00125   |
| Funai              | 01377   |
| <b>G</b> Galaxis   | 00853, 00863, 01101, 01111, 01557               |
| Gardiner           | 00818   |
| Garnet             | 01075   |
| GbSAT              | 01214   |
| GE                 | 00392, 00566                                    |
| Gecco              | 01412   |
| General Instrument | 00869   |
| General Satellite  | 01176   |
| GF Good Friends    | 01043   |
| GF Star            | 01043   |
| Globo              | 01251, 01334, 01412, 01429, 01626               |
| GOD Digital        | 00200   |
| GOI                | 00775, 01775                                    |
| Gold Box           | 00853   |
| Gold Vision        | 01631   |
| Golden Interstar   | 01283   |
| GoldStar           | 00394   |
| Goodmans           | 00455, 01284, 01291                             |
| Gradiente          | 00887   |
| Granada            | 00455   |
| Grundig            | 00173, 00345, 00847, 00853, 00879, 01291        |
| <b>H</b> Handan    | 01622   |
| Hanseatic          | 01099, 01100                                    |

|                        |   |
|------------------------|---|
| Hauptpage              | 01672   |
| HB                     | 01214, 01801  |
| HDT                    | 01159   |
| Hills                  | 01232   |
| Hirschmann             | 00125, 00173, 00299, 00710, 00882, 01085, 01111, 01232, 01412   |
| Hisense                | 01535   |
| Hitachi                | 00749, 00819, 00455, 01250, 01284, 01518, 01523, 01525  |
| Homecast               | 01214, 01680, 01700   |
| Hornet                 | 01300   |
| Houston                | 00775   |
| HTS                    | 00775, 01775  |
| Hughes Network Systems | 01142, 00749, 01749, 01442  |
| Humax                  | 00863, 01176, 01225, 01406, 01427, 01675, 01743, 01790, 01915   |
| Huth                   | 01075   |
| Hyundai                | 01075, 01159  |
| <b>I</b> iCan          | 01367   |
| ID Digital             | 01176   |
| ILLUSION sat           | 01557, 01631  |
| iLo                    | 01535   |
| Imperial               | 01334, 01429, 01672   |
| Indovision             | 00887   |
| Ingelen                | 00882   |
| Innova                 | 00099   |
| Interstar              | 01214   |
| InVideo                | 00871   |
| ISkyB                  | 00887   |
| Italtel                | 00871   |
| ITT Nokia              | 00455, 00723, 00873   |
| <b>J</b> Jadeworld     | 00642   |
| Jaeger                 | 01334   |
| Jerrold                | 00869   |
| Jiuzhou                | 01450   |
| JOK                    | 00710   |
| JVC                    | 00775, 01507, 01531, 01775  |
| <b>K</b> K-SAT         | 00713   |
| Kamm                   | 00713   |
| Kaon                   | 01300   |
| KaTelco                | 01111   |
| Kathrein               | 00123, 00173, 00200, 00249, 00394, 00442, 00480, 00504, 00658, 00713, 00818, 01221, 01416, 01561, 01567 |
| Kennex                 | 00125   |
| Kenwood                | 00853   |
| Klap                   | 00710   |
| Kocmoc TB              | 01333   |
| Koscom                 | 01043   |
| Kosmos                 | 00442, 01333  |
| Kreiling               | 00249, 00658  |

|                         |  |
|-------------------------|--|
| Kreismeyer              | 00173  |
| Kross                   | 01695  |
| <b>L</b> L&S Electronic | 01043, 01334   |
| Labgear                 | 01296  |
| LaSAT                   | 00173, 00299   |
| Lava                    | 01631  |
| Legend                  | 01718  |
| Legrand                 | 01718  |
| Lemon                   | 01334  |
| Lenco                   | 00713  |
| Lenoxx                  | 01611  |
| LG                      | 01075, 01414   |
| Lifesat                 | 00299, 00713, 01043                                    |
| Lodos                   | 01284  |
| Logik                   | 01284  |
| Logix                   | 01075  |
| Lorenzen                | 00299  |
| Luxor                   | 00345, 00873   |
| <b>M</b> M Electronic   | 00818  |
| M vision                | 01557  |
| Magnavox                | 00724, 00722   |
| Manata                  | 00710, 00713   |
| Manhattan               | 00455, 00710, 01083                                    |
| Marantz                 | 00200  |
| Maspro                  | 00173, 00713, 01530                                    |
| Master's                | 00394  |
| Matsui                  | 00173, 00710, 01284, 01743                             |
| Maximum                 | 01075, 01334, 01685                                    |
| McIntosh                | 00869  |
| MDS                     | 01225  |
| Mediabox                | 00853  |
| Mediacom                | 01206  |
| MediaSa                 | 00853  |
| Medion                  | 00299, 00713, 01043, 01075, 01232, 01334, 01412, 01626 |
| Medison                 | 00713  |
| Mega                    | 00200  |
| Memorex                 | 00724  |
| Metronic                | 00713, 00818, 01283, 01334, 01375, 01704               |
| Metz                    | 00173  |
| MiCO                    | 01811  |
| Micro                   | 00713  |
| Micro Elektronik        | 00713  |
| Micro Technology        | 00713  |
| Micromaxx               | 00299  |
| Microstar               | 01075  |
| Microtec                | 00713  |
| Mitsubishi              | 00749, 00455   |
| Morgan's                | 00200, 00713, 01232, 01412                             |
| Motorola                | 00869, 00856, 01473                                    |
| MTEC                    | 01214  |
| Muller                  | 01695  |

|                  |  |
|------------------|--|
| Multibroadcast   | 00642, 00879   |
| Multichoice      | 00642, 00879, 01333, 01433, 01559, 01560   |
| Mx Onda          | 01659  |
| Myriad           | 00200  |
| Mysat            | 00713  |
| MySky            | 01693, 01848, 01850  |
| <b>N</b> NEC     | 01519  |
| NEOTION          | 01334  |
| Netgem           | 01322  |
| Netsat           | 00099, 00887   |
| Neuf TV          | 01322  |
| Neuhaus          | 00713  |
| Neuling          | 01232  |
| Neusat           | 00713  |
| Nevir            | 01659  |
| Next Level       | 00869  |
| Nikko            | 00200, 00713, 00723  |
| Noda Electronic  | 01704  |
| Nokia            | 00455, 00723, 00751, 00853, 00873, 01023, 01223, 01723   |
| Nordmende        | 00455, 01611   |
| <b>O</b> OctalTV | 01505  |
| Okano            | 00442  |
| Omega            | 00887  |
| Opentel          | 01232, 01412   |
| Optex            | 00394, 00713, 01043, 01283, 01611  |
| Optimus          | 00724  |
| Optus            | 00879  |
| Orbis            | 01232, 01334, 01412  |
| Orbittech        | 01099, 01100   |
| Origo            | 00497  |
| OSAT             | 00345  |
| <b>P</b> P/Sat   | 01232  |
| Pace             | 00200, 00329, 00455, 00497, 00795, 00847, 00853, 00887, 01175, 01323, 01356, 01423, 01693, 01717, 01848, 01850 |
| Pacific          | 01284, 01375   |
| Packard Bell     | 01111  |
| Packsat          | 00710  |
| Palcom           | 00299, 01409   |
| Panarex          | 01159  |
| Panasat          | 00615, 00879, 01333, 01433   |
| Panasonic        | 00247, 00701, 00455, 00847, 01304, 01404, 01508, 01526, 01527  |
| Panda            | 00173, 00455   |
| Pansat           | 01159  |
| Patriot          | 00710  |
| Paysat           | 00724  |
| peekTon          | 01457  |

|                  |   |
|------------------|---|
| Philips          | 01142, 00749, 01749, 00775, 00724, 00819, 01076, 00722, 00099, 00710, 00455, 00818, 00200, 00847, 00853, 00173, 01114, 00133, 01442, 01543, 01672 |
| Phonotrend       | 00863, 01200  |
| Pilotime         | 01339   |
| Pino             | 01334   |
| Pioneer          | 01142, 00329, 00853, 01308, 01442   |
| Planet           | 00871   |
| Plasmatic        | 00442   |
| Neuf TV          | 00713, 01611  |
| Polytron         | 00394   |
| Portland         | 01296   |
| Preisner         | 00262, 01101, 01113, 01366  |
| Premier          | 00723, 00853, 00873, 01429  |
| Prima            | 00795   |
| Primacom         | 01111   |
| Primestar        | 00869   |
| Profile          | 00710   |
| Promax           | 00455   |
| Proscan          | 00392, 00566  |
| Proton           | 01535   |
| <b>Q</b> QNS     | 01367, 01402, 01404   |
| Quadral          | 00710   |
| Quelle           | 00299   |
| <b>R</b> Radiola | 00200   |
| RadioShack       | 00566, 00775, 00869   |
| Radix            | 00394, 00882, 01113, 01317  |
| RCA              | 00392, 00566, 01142, 00775, 00855, 00143, 01291, 01392, 01442   |
| Rebox            | 01214   |
| Regal            | 01251   |
| RFT              | 00200   |
| Roadstar         | 00713, 00853  |
| Rollmaster       | 01413   |
| Rover            | 00713   |
| Rownsonic        | 01567   |
| <b>S</b> SAB     | 01251   |
| Saba             | 00710, 00820  |
| Sabre            | 00455   |
| Sagem            | 00820, 01114, 01253, 01307, 01690   |
| Samsung          | 01377, 01142, 01276, 01108, 01109, 00853, 00863, 01206, 01442, 01458, 01570, 01609, 01700, 01916  |
| Sat Control      | 01300   |
| Sat Team         | 00713   |
| SAT+             | 01409   |
| Satec            | 00713   |
| Satelco          | 01232   |
| Satplus          | 01100   |



|                    |   |
|--------------------|---|
| Satstation         | 01083   |
| Schaub Lorenz      | 01214   |
| Schneider          | 00710, 01206, 01251   |
| Schwaiger          | 00394, 00504, 00863, 01075, 01083, 01111, 01317, 01334, 01412, 01457        |
| SCS                | 00299   |
| Sedea Electronique | 00125, 01206, 01283, 01626  |
| SEG                | 01075, 01087, 01251, 01626  |
| Seleco             | 00871   |
| Septimo            | 01375   |
| Serd               | 01412   |
| Serino             | 00610   |
| Servimat           | 01611   |
| ServiSat           | 00713, 01251  |
| Sharp              | 01517   |
| Siemens            | 00173, 01334, 01429   |
| Silva              | 00299   |
| Skantin            | 00713   |
| SKR                | 00713   |
| SKY                | 00856, 00099, 00847, 00887, 01014, 01175, 01662, 01693, 01847, 01848, 01850 |
| SKY Italia         | 00853, 01693, 01847, 01848  |
| Sky Television     | 01014   |
| Sky XL             | 01251, 01412  |
| Sky+               | 01175   |
| Skymaster          | 00713, 01075, 01085, 01200, 01334, 01409, 01567, 01611                      |
| Skymax             | 00200   |
| Skyplus            | 01232, 01334, 01412   |
| SkySat             | 00713   |
| Skyvision          | 01334   |
| SL                 | 00299, 01672  |
| SM Electronic      | 00713, 01200, 01409   |
| Smart              | 00713, 00882, 01101, 01113, 01232, 01404, 01413                             |
| Sony               | 00639, 01639, 00455, 00847, 00853, 01524, 01558, 01640                      |
| Star               | 00887   |
| Star Choice        | 00869   |
| Star Trak          | 00772, 00869  |
| Starland           | 00713   |
| Starlite           | 00200   |
| Stream             | 01847, 01848  |
| Strong             | 00125, 00713, 00820, 00853, 00879, 01159, 01284, 01300, 01409, 01626        |
| Sunkai             | 00123   |
| Sunny              | 01300   |
| Sunsat             | 00713   |
| Sunstar            | 00642   |
| Supernova          | 00887   |
| SVA                | 01455   |
| Systec             | 01334   |

|                        |  |
|------------------------|--|
| <b>T</b> Tantec        | 00455  |
| Tarbs                  | 01225  |
| Tatung                 | 00455  |
| TBoston                | 01659  |
| Teac                   | 01225, 01227, 01251, 01322   |
| Tecatel                | 01200  |
| TechniSat              | 00262, 00455, 00863, 01099, 01100, 01195, 01197, 01322   |
| Technomate             | 01283, 01610   |
| Technosonic            | 01672  |
| Technotrend            | 01429  |
| Techwood               | 01284, 01626   |
| Tele System Electronic | 01251, 01409, 01611, 01801   |
| Teleciel               | 01043  |
| TeleClub               | 01367  |
| Telefunken             | 00710  |
| Teleka                 | 00262, 00442   |
| Telestar               | 01099, 01100, 01251, 01334, 01610, 01626   |
| Telesystem             | 01801  |
| Televés                | 00455, 01214, 01300, 01334   |
| Televisa               | 00887  |
| Telewire               | 01232  |
| Tevion                 | 00713, 01409, 01622, 01672   |
| Thomson                | 00392, 00566, 00455, 00710, 00713, 00820, 00847, 00853, 01046, 01175, 01291, 01534, 01543, 01662 |
| Thorn                  | 00455  |
| Tiny                   | 01672  |
| Tioko                  | 00394  |
| Tivo                   | 01142, 01442   |
| Tokai                  | 00200  |
| Tonna                  | 00455, 00713, 01611  |
| Topfield               | 01206, 01208, 01545, 01783   |
| Toshiba                | 00749, 01749, 00790, 00819, 00455, 01285, 01501, 01516, 01530                                    |
| TPS                    | 00820, 01253, 01307  |
| Triax                  | 00200, 00713, 00853, 01113, 01227, 01251, 01291, 01296, 01626                                    |
| Trio                   | 01075  |
| TT-micro               | 01429  |
| Turnsat                | 00713  |
| Twinner                | 00713, 01611   |
| <b>U</b> UEC           | 00879, 01162, 01333, 01356   |
| UltimateTV             | 01392, 01640   |
| Uniden                 | 00724, 00722   |
| Unisat                 | 00200  |
| United                 | 01251  |
| Universum              | 00173, 00299, 01087, 01099, 01251  |
| US Digital             | 01535  |
| USDTV                  | 01535  |

|                     |   |
|---------------------|---|
| <b>V</b> Variosat   | 00173   |
| Ventana             | 00200   |
| Vestel              | 01251   |
| VH Sat              | 00299   |
| Viasat              | 01682   |
| ViewSat             | 01232   |
| Visionic            | 00125, 01283  |
| VisionNet           | 01557   |
| Visiosat            | 00142, 00710, 00713, 01413, 01457, 01718                      |
| Viva                | 00856   |
| Vivid               | 01162   |
| Voom                | 00869   |
| VTech               | 00818   |
| <b>W</b> Wavelength | 01232, 01413  |
| Wewa                | 00455   |
| Wharfedale          | 01284   |
| Winbox              | 01801   |
| Wintel              | 00299   |
| Wisi                | 00173, 00299, 00455   |
| Worldsat            | 00123, 00710, 01214, 01251, 01543                             |
| <b>X</b> Xcom       | 00123   |
| XMS                 | 01075   |
| Xsat                | 00123, 00713, 00847, 01214, 01323                             |
| Xtreme              | 01300   |
| <b>Y</b> Yakumo     | 01413   |
| Yamada              | 01718   |
| Yes                 | 00887   |
| Zehnder             | 00394, 00504, 00818, 01075, 01232, 01251, 01334, 01412, 01413 |
| Zenith              | 00856, 01856  |
| Zeta Technology     | 00200   |
| Zodiac              | 01801   |

### Satellite Receiver/ PVR Combination ※1, ※3

|                          |              |
|--------------------------|--------------|
| ※1                       |              |
| <b>A</b> @sat            | 01300        |
| Allvision                | 01412        |
| Amstrad                  | 01175        |
| Atsat                    | 01300        |
| <b>B</b> B@ytronic       | 01412        |
| British Sky Broadcasting | 01175        |
| BskyB                    | 01175, 01662 |
| Bush                     | 01645        |
| <b>C</b> Canal Satellite | 01339        |
| Comag                    | 01412        |
| <b>D</b> Digi fusion     | 01645        |
| DigiQuest                | 01300        |
| Digiturk                 | 01076        |

|                        |   |
|------------------------|---|
| DirecTV                | 01377, 00392, 00639, 01142, 01076, 00099, 01392, 01442, 01640 |
| Dish Network System    | 01505, 00775  |
| Dishpro                | 01505, 00775  |
| DMT                    | 01075   |
| Dream Multimedia       | 01237   |
| <b>E</b> EchoStar      | 01505, 00775, 00610   |
| Expressvu              | 00775   |
| <b>F</b> Foxtel        | 01356   |
| <b>G</b> GbSAT         | 01214   |
| Gecco                  | 01412   |
| Globo                  | 01412   |
| <b>H</b> HDT           | 01159   |
| Hirschmann             | 01412   |
| Homecast               | 01680   |
| Hughes Network Systems | 01142, 01442  |
| Humax                  | 01176, 01427, 01675   |
| Huth                   | 01075   |
| Hyundai                | 01075, 01159  |
| <b>K</b> Kaon          | 01300   |
| Kathrein               | 00249, 00658, 01221, 01561                                    |
| <b>L</b> LG            | 01075   |
| <b>M</b> Maximum       | 01334   |
| Mediacom               | 01206   |
| Medion                 | 01412   |
| Microstar              | 01075   |
| Morgan's               | 01412   |
| Motorola               | 00869   |
| MTEC                   | 01214   |
| Multichoice            | 01333, 01559, 01560   |
| MySky                  | 01693, 01848, 01850   |
| <b>N</b> NEOTION       | 01334   |
| Nokia                  | 01023   |
| <b>O</b> Opentel       | 01412   |
| Orbis                  | 01412   |
| <b>P</b> Pace          | 01175, 01356, 01423, 01850                                    |
| Panasonic              | 01304   |
| Philips                | 01142, 00099, 01442   |
| Pilotime               | 01339   |
| Proscan                | 00392   |
| <b>R</b> Radix         | 01317   |
| RCA                    | 01392   |
| Rebox                  | 01214   |
| <b>S</b> Sagem         | 01253, 01307  |
| Samsung                | 01206, 01442, 01570, 01609                                    |
| Sat Control            | 01300   |
| Schneider              | 01206   |
| Schwaiger              | 01075, 01412  |
| Sedea Electronique     | 01206   |
| Serd                   | 01412   |
| SKY                    | 01175, 01693, 01848, 01850                                    |

|                    |                     |
|--------------------|---------------------|
| SKY Italia         | 01848               |
| Sky XL             | 01412               |
| Skymaster          | 01075               |
| Skyplus            | 01412               |
| Sony               | 00639, 01640        |
| Star Choice        | 00869               |
| Strong             | 01300               |
| Sunny              | 01300               |
| <b>T</b> TechniSat | 01195, 01197        |
| Thomson            | 01175, 01534, 01662 |
| Topfield           | 01206, 01545, 01783 |
| TPS                | 01253, 01307        |
| <b>X</b> Xtreme    | 01300               |
| <b>Z</b> Zehnder   | 01075, 01412        |

### ※3

|                                 |       |
|---------------------------------|-------|
| <b>H</b> Hughes Network Systems | 20739 |
| <b>P</b> Philips                | 20739 |
| <b>S</b> Samsung                | 20739 |

### Television

|                   |   |
|-------------------|---|
| <b>1</b> 888      | 10264   |
| <b>A</b> A-Mark   | 10047, 10054, 10009   |
| A.R. Systems      | 10037, 10352, 10374, 10455, 10556   |
| Accent            | 10009, 10037  |
| Accuscan          | 10047   |
| Accuscreen        | 10001   |
| Acoustic Research | 11269   |
| Action            | 10030, 10650  |
| Acura             | 10009   |
| Addison           | 10092, 10108, 10653   |
| ADL               | 11217   |
| Admiral           | 10047, 10054, 10017, 10051, 10093, 10463, 10180, 10163, 10264, 10418  |
| Advent            | 10761, 10783, 10815, 10817, 10842, 10876, 11933   |
| Adventuri         | 10000   |
| Adyson            | 10217   |
| AEG               | 11163, 11556  |
| Agashi            | 10217, 10264  |
| Agna              | 10150   |
| Aiko              | 10092, 10009, 10035, 10037, 10217, 10264, 10361, 10371, 10433   |
| Aim               | 10706, 10037, 10455, 10805  |
| Aiwa              | 10264, 10701, 11904, 11911  |
| Akai              | 10000, 10060, 10812, 10702, 10178, 10030, 10145, 10602, 10606, 10631, 10648, 10672, 10714, 10715, 11207, 11537, 11675, 11676, 11903, 10556, 10548, 10480, 10433, 10371, 10361, 10264, 10218, 10217, 10208, 10163, 10037, 10035, 10009 |

|                |   |
|----------------|---|
| Akashi         | 10009, 10860  |
| Akiba          | 10037, 10218, 10455   |
| Akira          | 10418   |
| Akito          | 10037   |
| Akura          | 10171, 10009, 10037, 10163, 10218, 10264, 10668, 10714, 11037, 11498, 11556, 11982                      |
| Alaron         | 10170   |
| Alba           | 10009, 10036, 10037, 10073, 10163, 10218, 10352, 10370, 10371, 10418, 10443, 10487, 10668, 10714, 11037 |
| Albatron       | 10700, 10843  |
| Alfide         | 10672   |
| All-Tel        | 10865, 11269  |
| Alleron        | 10030, 10170  |
| Allorgan       | 10217   |
| Allstar        | 10037   |
| Ambassador     | 10150   |
| America Action | 10180   |
| American High  | 10000, 10060  |
| Amplivision    | 10217, 10370  |
| Amstrad        | 10000, 10171, 10009, 10011, 10037, 10163, 10218, 10264, 10362, 10371, 10433, 10648, 11037, 11982        |
| Amtron         | 10000, 10180  |
| Anam           | 10250, 10180, 10009, 10037, 10700, 10861  |
| Anam National  | 10250, 10037, 10650   |
| Andersson      | 11149, 11163  |
| Anglo          | 10009, 10264  |
| Anhua          | 10051   |
| Anitech        | 10009, 10037, 10264   |
| Ansonic        | 10009, 10037, 10163, 10370, 10374, 10668  |
| AOC            | 10451, 10093, 10180, 10060, 10178, 10030, 10092, 10009, 10108   |
| Aolinpike      | 10264   |
| Apex Digital   | 10156, 10748, 10879, 10765, 10767, 11217, 11943   |
| AR             | 10352, 10556  |
| Arc En Ciel    | 10109   |
| Arcam          | 10217   |
| Ardem          | 10037, 10714  |
| Aristocrat     | 10163   |
| Aristona       | 10037, 10556  |
| ART            | 11037   |
| Arthur Martin  | 10163   |
| ASA            | 10070   |
| Asberg         | 10037   |
| Asora          | 10009   |
| Astra          | 10037   |
| Asuka          | 10217, 10218, 10264   |
| ATD            | 10698   |
| Atlantic       | 10001, 10037  |

|                |  |
|----------------|--|
| Atori          | 10009  |
| Auchan         | 10163  |
| Audinac        | 10180  |
| Audiosonic     | 10009, 10037, 10109, 10217, 10218, 10264, 10370, 10374, 10486, 10714, 10715, 10820 |
| Audioton       | 10217, 10264, 10370, 10486   |
| Audiovox       | 10451, 10180, 10092, 10623, 10802, 10875, 11937, 11951, 11952                      |
| Audioworld     | 10698  |
| Aumark         | 10060  |
| Autovox        | 10217  |
| Aventura       | 10171  |
| AVP            | 10000  |
| Awa            | 10451, 10009, 10011, 10036, 10108, 10217, 10264, 10374, 10606                      |
| Axon           | 11937, 11958   |
| Axxent         | 10009  |
| Baier          | 10876  |
| Baihe          | 10009, 10264   |
| Baile          | 10001, 10009, 10374, 10661   |
| Baird          | 10037, 10073, 10109, 10208, 10217, 10343, 11196                                    |
| Bang & Olufsen | 10565  |
| Baohuashi      | 10264  |
| Baosheng       | 10009, 10817   |
| Barco          | 10163, 10556   |
| Basic Line     | 10009, 10037, 10163, 10217, 10218, 10374, 10455, 10556, 10668, 11037, 11163        |
| Bastide        | 10217  |
| Bauer          | 10805  |
| Baur           | 10037, 10195, 10361, 10455, 10512  |
| Baysonic       | 10180  |
| Bazin          | 10217  |
| Beaumarck      | 10017, 10178, 10030  |
| Beijing        | 10812, 10001, 10009, 10208, 10226, 10264, 10374, 10661, 10817, 10821               |
| Beko           | 10037, 10195, 10370, 10418, 10486, 10606, 10714, 10715, 10808, 11037               |
| Belcor         | 10030  |
| Bell & Howell  | 10054, 10017, 10154, 10093   |
| Belson         | 10698, 11191   |
| Belstar        | 11037  |
| BenQ           | 11032, 11756   |
| Beon           | 10037, 10163, 10218, 10418   |
| Berthen        | 10668  |
| Best           | 10370  |
| Bestar         | 10037, 10370, 10374  |
| Bestar-Daewoo  | 10374  |
| Binatone       | 10217  |
| Black Diamond  | 10614, 10820, 10821, 11037, 11163, 11909   |

**B**

|            |   |
|------------|---|
| Blackway   | 10218   |
| Blaupunkt  | 10036, 10170, 10195, 10200, 10327, 10455  |
| Blue Sky   | 10037, 10218, 10455, 10487, 10499, 10556, 10668, 10714, 10715, 11037, 11191, 11363  |
| Boots      | 10009, 10217  |
| BPL        | 10037, 10208  |
| Bradford   | 10180   |
| Brandt     | 10109, 10287, 10335, 10560, 10625, 10714  |
| Brinkmann  | 10037, 10418, 10486, 10668  |
| Brionvega  | 10037, 10362  |
| Britannia  | 10217   |
| Brockwood  | 10178, 10030  |
| Broksonic  | 10236, 10463, 10180, 11911, 11938   |
| Brother    | 10264   |
| BSR        | 10163   |
| BTC        | 10218   |
| Bush       | 11900, 11556, 11037, 10778, 10714, 10698, 10668, 10661, 10614, 10556, 10487, 10374, 10371, 10361, 10335, 10264, 10218, 10217, 10208, 10163, 10037, 10036, 10009 |
| Caihong    | 10009, 10817  |
| Cailing    | 10748   |
| Candle     | 10030   |
| Canton     | 10218   |
| Capehart   | 10017, 10178, 10030, 10092, 10036   |
| Capetronic | 10030   |
| Capsonic   | 10264   |
| Carad      | 10610, 10668, 11037   |
| Carena     | 10037, 10455  |
| Carnivale  | 10030   |
| Carrefour  | 10036, 10037, 10070   |
| Carver     | 10054, 10170  |
| Cascade    | 10009, 10037  |
| Casio      | 10037   |
| Cathay     | 10037, 10218  |
| CCE        | 10037, 10217  |
| Celebrity  | 10000   |
| Celera     | 10765   |
| Celestial  | 10767, 10819, 10820, 10821  |
| Centrex    | 10780   |
| Centrum    | 11037   |
| Centurion  | 10037   |
| CGE        | 10074, 10163, 10370, 10418  |
| Changcheng | 10051, 10001, 10009, 10264, 10374, 10661, 10817   |
| Changfei   | 10009, 10374, 10817   |
| Changfeng  | 10264, 10817  |
| Changhai   | 10009, 10817  |

**C**

|                      |  |
|----------------------|--|
| Changhong            | 10156, 10765, 10009, 10264, 10508, 10767, 10783, 10817, 10819, 10820, 10821, 11008, 11156                                    |
| Chengdu              | 10009, 10817   |
| Ching Tai            | 10092, 10009   |
| Chun Yun             | 10000, 10180, 10092, 10009, 10700, 10843   |
| Chunfeng             | 10009, 10264   |
| Chung Hsin           | 10180, 10053, 10036, 10108   |
| Chunsun              | 10009, 10817   |
| Cimline              | 10009, 10218   |
| Cinema               | 10672  |
| Cineral              | 10451, 10092   |
| Cinex                | 10648, 11556   |
| Citek                | 10047  |
| Citizen              | 10054, 10000, 10451, 10463, 10180, 10060, 10030, 10171, 10092, 10001, 10035  |
| City                 | 10009  |
| Clarion              | 10180  |
| Clarivox             | 10037, 10070, 10418  |
| Classic              | 10030, 10092, 10499  |
| Clatronic            | 10009, 10037, 10217, 10218, 10264, 10370, 10371, 10714   |
| Clayton              | 11037  |
| CMS Hightec          | 10217  |
| Colortyme            | 10047, 10054, 10017, 10060, 10178, 10030   |
| Commercial Solutions | 11447, 10047   |
| Concorde             | 10009  |
| Condor               | 10009, 10037, 10264, 10370, 10418  |
| Conia                | 10820, 10821, 11498  |
| Conic                | 10178  |
| Conrac               | 10808  |
| Conrowa              | 10156, 10145, 10009, 10264, 10698, 11156, 11170  |
| Contec               | 10180, 10009, 10036, 10037   |
| Continental Edison   | 10109, 10287, 10487  |
| Cosmel               | 10009, 10037   |
| Craig                | 10180, 10171   |
| Crosley              | 10054, 10000, 10180, 10030, 10171, 10074, 10163, 10370   |
| Crown                | 10093, 10180, 10053, 10009, 10037, 10208, 10370, 10418, 10486, 10487, 10606, 10672, 10712, 10714, 10715, 11037               |
| Crown Mustang        | 10672  |
| CS Electronics       | 10218  |
| CTX                  | 11756  |
| Curtis Mathes        | 10047, 10054, 10154, 10000, 10051, 10451, 10093, 10180, 10060, 10702, 10178, 10030, 10145, 10166, 10037, 10035, 11147, 11347 |
| CXC                  | 10180  |
| Cybertron            | 10218  |
| Cytronix             | 11298  |

**D**

|          |                     |
|----------|---------------------|
| D-Vision | 10037, 10556, 11982 |
|----------|---------------------|

|              |   |
|--------------|---|
| Daewoo       | 10154, 10451, 10180, 10178, 10030, 10092, 11661, 10634, 10661, 10672, 10700, 10860, 10865, 10876, 10880, 11755, 11756, 11909, 10623, 10556, 10499, 10374, 10264, 10218, 10217, 10170, 10109, 10108, 10037, 10036, 10009 |
| Dainichi     | 10218   |
| Dansai       | 10009, 10035, 10036, 10037, 10208, 10217  |
| Dantax       | 10370, 10486, 10714, 10715  |
| Datsura      | 10208   |
| Dawa         | 10009, 10037  |
| Daytek       | 10672, 11207  |
| Dayton       | 10092, 10009, 11207   |
| Daytron      | 10180, 10178, 10030, 10092, 10009, 10036, 10037, 10374  |
| Dayu         | 10374, 10661  |
| De Graaf     | 10163, 10208, 10548   |
| Decca        | 10037, 10217  |
| Degraff      | 10163, 10208  |
| Deitron      | 10374   |
| Dell         | 11080, 11178  |
| Denko        | 10264   |
| Denon        | 10145, 10511  |
| Denver       | 10037, 10587  |
| Desmet       | 10009, 10037  |
| Diamant      | 10037   |
| Diamond      | 10706, 10009, 10371, 10672, 10698, 10820, 10860   |
| Digatron     | 10037   |
| Digiline     | 10037, 10668  |
| Digital Life | 10872   |
| Digitex      | 10820   |
| Digitor      | 10037   |
| Digix Media  | 10880   |
| Dixi         | 10009, 10037, 10217   |
| DL           | 10587, 10780, 10872   |
| Domeos       | 10668   |
| Domland      | 10394   |
| Dongda       | 10009   |
| Donghai      | 10009   |
| Dream Vision | 11164, 11704  |
| DSE          | 10698, 10820, 11556   |
| DTS          | 10009   |
| Dual         | 10037, 10217, 10343, 10352, 10394, 11037, 11137   |
| Dual Tec     | 10217   |
| Dumont       | 10017, 10180, 10178, 10070, 10217   |
| Durabrand    | 10463, 10180, 10178, 10171, 11034, 11463  |
| Dux          | 10037   |
| Dwin         | 10093   |
| Dynatech     | 10217   |
| Dynatron     | 10037   |

|          |                    |  |
|----------|--------------------|--|
| <b>E</b> | Easy Living        | 11248  |
|          | Eaton              | 10060  |
|          | Ecco               | 10773  |
|          | ECE                | 10037  |
|          | Edison-Minerva     | 10487  |
|          | Elbe               | 10037, 10217, 10218, 10362, 10610  |
|          | Elcit              | 10163  |
|          | Electroband        | 10000  |
|          | Electrograph       | 11755  |
|          | Electrohome        | 10154, 10000, 10463, 10150, 10178, 10030, 10073  |
|          | Elekta             | 10009, 10264   |
|          | Elfunk             | 11037, 11208   |
|          | ELG                | 10037  |
|          | Elin               | 10009, 10037, 10361, 10548   |
|          | Elite              | 10037, 10218   |
|          | Elta               | 10009, 10264   |
|          | Emerald            | 10178  |
|          |                    | 10047, 10017, 10154, 10451, 10236, 10463, 10180, 10150, 10178, 10171, 11944, 11911, 11909, 10714, 10668, 10623, 10486, 10036, 10371, 10370, 10361, 10037, 10195, 10170, 10070, 10073 |
|          | Envision           | 10030, 10813   |
|          | Enzer              | 10860  |
|          | Erae               | 11371  |
|          | Erres              | 10037  |
|          | ESA                | 10812, 10171, 11944  |
|          | ESC                | 10037, 10217   |
|          | Ether              | 10030, 10009   |
|          | Etron              | 10001, 10009, 10163, 10820   |
|          | Eurofeel           | 10217, 10264   |
|          | Euroman            | 10037, 10217, 10264, 10370   |
|          | Europa             | 10037  |
|          | Europhon           | 10037, 10109, 10217  |
|          | Evesham Technology | 11248  |
|          | Evolution          | 11756  |
|          | Expert             | 10163  |
|          | Exquisit           | 10037  |
| <b>F</b> | Feilang            | 10009  |
|          | Feilu              | 10009, 10817   |
|          | Feiyan             | 10264  |
|          | Feiyue             | 10009, 10817   |
|          | Fenner             | 10009, 10374   |
|          | Fer0               | 10335  |
|          |                    | 10053, 10037, 10073, 10109, 10195, 10287, 10335, 10343, 10443, 10548, 10560, 10625, 11037  |
|          | Ferguson           | 10171, 10037, 10163, 10217, 10264, 10361, 10371, 10512   |
|          | Fidelity           | 10217  |
|          | Filsai             | 10217  |
|          | Finlandia          | 10163, 10208, 10346, 10361, 10548  |

|          |                 |  |
|----------|-----------------|--|
|          | Finlux          | 10037, 10070, 10163, 10217, 10346, 10480, 10556, 10631, 10714, 10715, 10808, 11556   |
|          | Firstar         | 10236, 10009   |
|          | Firstline       | 10009, 10037, 10208, 10217, 10361, 10374, 10556, 10668, 10714, 10808, 11037, 11191, 11363, 11371   |
|          | Fisher          | 10047, 10054, 10154, 10000, 10036, 10208, 10217, 10361, 10370  |
|          | Flint           | 10037, 10218, 10264, 10455, 10610  |
|          | Force           | 11149  |
|          | Formenti        | 10037, 10163   |
|          | Fortress        | 10093  |
|          | Fraba           | 10037, 10370   |
|          | Friac           | 10009, 10037, 10370, 10499, 10610  |
|          | Frontech        | 10009, 10163, 10217, 10264   |
|          | Fujimaro        | 10865, 11498   |
|          | Fujitsu         | 10009, 10217, 10352, 10683, 10809, 10853   |
|          | Fujitsu General | 10009, 10217, 10683  |
|          | Fujitsu Siemens | 10808, 10809, 11163, 11298   |
|          | Funai           | 10000, 10180, 10171, 10264, 10668, 11271, 11904  |
|          | Furi            | 10145, 10264, 10817  |
|          | Furichi         | 10860  |
|          | Futronic        | 10264, 10860   |
|          | Futuretech      | 10180  |
| <b>G</b> | Galaxi          | 10037  |
|          | Galaxis         | 10037, 10370   |
|          | Ganxin          | 10817  |
|          | Gateway         | 11755, 11756   |
|          | GBC             | 10009, 10163, 10218, 10374   |
|          |                 | 11447, 10047, 11454, 10000, 10051, 10451, 10093, 10180, 10060, 10178, 10030, 10092, 11922, 11917, 11347, 11147, 10625, 10560, 10335, 10035 |
|          | GE              | 10037, 10163, 10217, 10361   |
|          | GEC             | 10009, 10037, 10217, 10361   |
|          | Geloso          | 10009, 10163, 10374  |
|          | Gemini          | 10047  |
|          | General         | 10109, 10287   |
|          | General Technic | 10009  |
|          | Genesis         | 10009, 10037   |
|          | Genexxa         | 10009, 10037, 10163, 10218   |
|          | Gericom         | 10808, 10865, 10880, 11217, 11298  |
|          | Gevalt          | 11371  |
|          | Giant           | 10009, 10217   |
|          | Gibraltar       | 10017, 10000, 10030  |
|          | Go Video        | 10060, 10886   |
|          | Go Vision       | 11937  |
|          | Goldfunk        | 10668  |
|          |                 | 10047, 10054, 10154, 10178, 10030, 10715, 10714, 10606, 10455, 10361, 10217, 10163, 10109, 10073, 10037, 10036, 10009, 10061               |
|          | GoldStar        | 10009, 10061   |

|          |                 |  |
|----------|-----------------|--|
|          | Gooding         | 10487  |
|          |                 | 10000, 11909, 11900, 11163, 11037, 10880, 10808, 10714, 10668, 10661, 10634, 10625, 10587, 10560, 10556, 10499, 10487, 10480, 10374, 10371, 10343, 10335, 10264, 10218, 10217, 10037, 10036, 10035, 10011, 10009 |
|          | Goodmans        | 10009, 10037, 10108, 10163, 10208, 10217, 10226, 10343, 10548, 10560   |
|          | Gorenje         | 10370  |
|          | GPM             | 10218  |
|          | Gradiente       | 10053, 10037, 10170  |
|          | Graetz          | 10163, 10361, 10371, 10487, 10714, 11163   |
|          | Gran Prix       | 10648  |
|          | Granada         | 10036, 10037, 10108, 10163, 10208, 10217, 10226, 10343, 10548, 10560   |
|          | Grandin         | 10009, 10037, 10163, 10218, 10374, 10455, 10610, 10668, 10714, 10715, 10865, 10880, 11037, 11191   |
|          | Gronic          | 10217  |
|          |                 | 10706, 10009, 10036, 10037, 10070, 10163, 10195, 10443, 10487, 10556, 10587, 10672, 10683, 11371   |
|          | Grundig         | 10180, 10195   |
|          | Grundy          | 11163  |
|          | Grunpy          | 10180  |
| <b>H</b> | H & B           | 10808  |
|          | Haaz            | 10706  |
|          | Galaxi          | 11034, 10037, 10508, 10587, 10698, 11017   |
|          | Haihong         | 10009  |
|          | Haiyan          | 10264, 10817   |
|          | Halifax         | 10217, 10264   |
|          | Hallmark        | 10236, 10180, 10178  |
|          | Hampton         | 10217  |
|          | Hanimex         | 10218  |
|          | Hankook         | 10180, 10178, 10030  |
|          |                 | 10009, 10037, 10217, 10361, 10370, 10394, 10499, 10556, 10634, 10661, 10714, 10808   |
|          | Hanseatic       | 10009, 10037, 10217, 10361, 10370, 10394, 10499, 10556, 10634, 10661, 10714, 10808   |
|          | Hantarex        | 10009, 10037, 10865  |
|          | Hantor          | 10037  |
|          | Harley Davidson | 10000, 10180, 10060, 10178, 10030, 11904   |
|          | Harman/Kardon   | 10054  |
|          | Harsper         | 10865  |
|          | Harvard         | 10180  |
|          | Harwa           | 10773, 11196, 11269  |
|          | Harwood         | 10009, 10037, 10487  |
|          | Hauppauge       | 10037  |
|          | Havermy         | 10093  |
|          | HCM             | 10009, 10037, 10217, 10218, 10264, 10418   |
|          | Heathkit        | 10017  |
|          | Helios          | 10865  |
|          | Hello Kitty     | 10451  |

|          |                  |  |
|----------|------------------|--|
|          | Hema             | 10009, 10217   |
|          | Hewlett Packard  | 11494, 11502   |
|          | Hifivox          | 10109  |
|          | Highline         | 10037, 10264   |
|          | Hikona           | 10218  |
|          | Hikone           | 10218  |
|          | Hinari           | 10009, 10036, 10037, 10163, 10208, 10218, 10264, 10352, 10443  |
|          | Hisawa           | 10218, 10455, 10610, 10714   |
|          |                  | 10156, 10748, 10145, 10009, 10208, 10508, 10556, 10780, 10821, 10860, 11022, 11156, 11170, 11208, 11363  |
|          | Hisense          | 10047, 10054, 10017, 10000, 11256, 10156, 10051, 10150, 10178, 10030, 11145, 10145, 10092, 10744, 10877, 10634, 11037, 11137, 11149, 11156, 11170, 11225, 11576, 11904, 11960, 10578, 10548, 10508, 10499, 10481, 10480, 10343, 10217, 10163, 10109, 10108, 10037, 10036, 10035, 10009 |
|          | Hitachi          | 10150, 10108, 10860  |
|          | Hitachi Fujian   | 10150, 10108, 10860  |
|          | Hitec            | 10698  |
|          | Hitsu            | 10009, 10218, 10455, 10610   |
|          | Hoehner          | 10714, 10865, 11163, 11556   |
|          | Home Electronics | 10606  |
|          | Hongmei          | 10093, 10009, 10264, 10817   |
|          | Hongyan          | 10264, 10817   |
|          | Hornophon        | 10037  |
|          | Hoshai           | 10218, 10455   |
|          | HP               | 11494, 11502   |
|          | Hua Tun          | 10009  |
|          | Huafa            | 10145, 10009   |
|          | Huanghai mei     | 10009  |
|          | Huanghe          | 10009, 10817   |
|          | Huanglong        | 10009  |
|          | Huangshan        | 10009, 10264, 10817  |
|          | Huanyu           | 10217, 10264, 10374, 10817   |
|          | Huaqiang         | 10264  |
|          | Huari            | 10145, 10264   |
|          | Hugoson          | 11217  |
|          | Huodateji        | 10051  |
|          | Hygashi          | 10217  |
|          | Hyper            | 10009, 10217   |
|          | Hypersonic       | 10361  |
|          |                  | 10037, 10217, 10264, 10455, 10486, 10556, 10668, 10714, 10715, 11037   |
|          | Hypson           | 10037, 10217, 10264, 10455, 10486, 10556, 10668, 10714, 10715, 11037   |
|          | Hyundai          | 10849, 10860, 10865, 10876, 11556  |
| <b>I</b> | Iberia           | 10037  |
|          | ICE              | 10037, 10217, 10218, 10264, 10371  |
|          | ICeS             | 10218  |
|          | Iiyama           | 10877, 11217   |

|          |                |   |
|----------|----------------|---|
|          | Ima            | 10236, 10180, 10178   |
|          | Imperial       | 10037, 10074, 10370, 10418  |
|          | Imperial Crown | 10001, 10009, 10264, 10374, 10661   |
|          | Indiana        | 10037   |
|          | Infinity       | 10054   |
|          | InFocus        | 11164   |
|          | Ingelen        | 10163, 10487, 10610, 10714  |
|          | Ingersol       | 10009   |
|          | Inno Hit       | 10009, 10217, 10218, 11163  |
|          | Innova         | 10037   |
|          | Innowert       | 10865, 11298  |
|          | Inotech        | 10773, 10820  |
|          | Insignia       | 10171, 11517  |
|          | Inteq          | 10017, 10145  |
|          | Interbuy       | 10009, 10037, 10264   |
|          | Interfunk      | 10037, 10109, 10163, 10200, 10327, 10361, 10512                             |
|          | Internal       | 10037, 11909  |
|          | Intervision    | 10009, 10037, 10217, 10218, 10264, 10394, 10455, 10486, 10487               |
|          | Irradio        | 10009, 10037, 10218, 10371  |
|          | Isukai         | 10037, 10218, 10455   |
|          | ITC            | 10217   |
|          | ITS            | 10037, 10218, 10264, 10371  |
|          | ITT            | 10163, 10208, 10346, 10361, 10480, 10548, 10610                             |
|          |                | 10070, 10163, 10195, 10208, 10346, 10361, 10480, 10548, 10606, 10610        |
|          | ITT Nokia      | 10070, 10163, 10195, 10208, 10346, 10361, 10480, 10548, 10606, 10610        |
|          | ITV            | 10037, 10264, 10374   |
|          | IX             | 10877   |
| <b>J</b> | JBL            | 10054   |
|          | JCB            | 10000   |
|          | JDV            | 11982   |
|          | Jean           | 10156, 10051, 10236, 10092, 10009, 10036                                    |
|          | JEC            | 10035   |
|          | Jensen         | 10761, 10815, 10817, 11933  |
|          | Jiahua         | 10051   |
|          | JiaLiCai       | 10009, 10264  |
|          | JIL            | 10030   |
|          | Jinfeng        | 10051, 10208, 10226, 10817  |
|          | Jinque         | 10009, 10264, 10817   |
|          | Jinta          | 10009, 10264  |
|          |                | 10054, 10156, 10145, 10009, 10037, 10264, 10556, 10698, 10817, 10821, 11011 |
|          | Jinxing        | 10037, 10264, 10556, 10698, 10817, 10821, 11011                             |
|          | JMB            | 10443, 10499, 10556, 10634  |
|          | JNC            | 10876   |
|          | Jocel          | 10712   |
|          | Johnson        | 10455   |
|          | Jubilee        | 10556   |
|          | Juhua          | 10264, 10817  |
|          | Jutan          | 10030   |

|                |  |
|----------------|--|
| JVC            | 10054, 10093, 10463, 10053, 10030, 10070, 10036, 10218, 10371, 10418, 10508, 10606, 10650, 10653, 10683, 10731, 11253, 11923 |
| <b>K</b> Kaige | 10009, 10264, 10817  |
| Kaisui         | 10009, 10037, 10217, 10218, 10455  |
| Kambrook       | 10217  |
| Kamp           | 10017, 10180, 10217  |
| Kangli         | 10001, 10009, 10264, 10374, 10661, 10817   |
| Kangyi         | 10009, 10264   |
| Kapsch         | 10163, 10361   |
| Karcher        | 10264, 10370, 10606, 10610, 10714, 10778, 11556  |
| Kathrein       | 10556  |
| Kawa           | 10371  |
| Kawasho        | 10030  |
| KB Aristocrat  | 10163  |
| KDS            | 11498  |
| KEC            | 10180, 10060   |
| Kendo          | 10037, 10362, 10370, 10610, 10648, 11037   |
| Kennedy        | 10163  |
| Kennex         | 10668, 11037   |
| Kenwood        | 10180, 10030   |
| Khind          | 10706  |
| KIC            | 10217  |
| Kiota          | 10001, 10371, 10455  |
| Kioto          | 10706, 10556   |
| Kiton          | 10037, 10668   |
| KLH            | 10156, 10180, 10765, 10767, 11962  |
| KLL            | 10037  |
| Kloss          | 10030  |
| Kneissel       | 10037, 10362, 10370, 10374, 10499, 10556, 10610  |
| Kolin          | 10180, 10150, 10053, 10036, 10108, 11331   |
| Kolster        | 10037, 10218   |
| Kongque        | 10009, 10264, 10817  |
| Konichi        | 10009  |
| Konig          | 10037  |
| Konka          | 10180, 10037, 10218, 10371, 10418, 10587, 10641, 10714, 10817, 11084   |
| Kontakt        | 10487  |
| Korpel         | 10037  |
| Korting        | 10370  |
| Kosmos         | 10037  |
| Koyoda         | 10009  |
| Kreisen        | 10876  |
| KTV            | 10463, 10180, 10030, 10217   |
| Kuaile         | 10009, 10264   |
| Kulun          | 10009  |
| Kunlun         | 10051, 10208, 10226, 10264, 10374, 10661, 10817  |

|                       |  |
|-----------------------|--|
| <b>L</b> Kyoshu       | 10418  |
| Kyoto                 | 10163, 10217   |
| L&S Electronic        | 10714, 10808, 10865  |
| Lark                  | 10154  |
| LaSAT                 | 10486  |
| Lavis                 | 11037  |
| Leader                | 10009  |
| Lecson                | 10037  |
| Legend                | 10009  |
| Lenco                 | 10037, 10374, 10587  |
| Lenoir                | 10009  |
| Lexsor                | 11196  |
| Leyco                 | 10037, 10264   |
| LG                    | 10054, 11265, 10060, 10178, 10030, 11758, 11637, 11191, 11178, 10856, 10715, 10714, 10700, 10698, 10556, 10370, 10361, 10217, 10163, 10109, 10108, 10037, 10009, 10001 |
| Liesenk & Tter        | 10037  |
| Liesenkotter          | 10037, 10327   |
| Lifetec               | 10009, 10037, 10218, 10374, 10668, 10683, 10714, 11037, 11137  |
| Lihua                 | 10817  |
| Lloyd's               | 10236, 10180, 10030, 10001, 10009, 11904   |
| Local India TV        | 10009, 10208, 10602  |
| Local Malaysia TV     | 10698  |
| Lodos                 | 11037  |
| Loewe                 | 10037, 10370, 10512, 10633, 10790  |
| Logik                 | 10236, 10180, 10060, 10001, 10009, 10011, 10371, 10698, 10773, 10880, 11037, 11217   |
| Logix                 | 10668  |
| Longjiang             | 10264, 10817   |
| Luker                 | 11982  |
| Luma                  | 10009, 10163, 10362, 10374, 11037  |
| Lumatron              | 10037, 10073, 10163, 10217, 10264, 10361, 10556  |
| Lux May               | 10009, 10037   |
| Luxor                 | 10163, 10208, 10217, 10346, 10361, 10480, 10548, 10631, 11037, 11163   |
| LXI                   | 10047, 10054, 10017, 10154, 10000, 10156, 10051, 10093, 10060, 10053, 10178, 10030, 10171, 10166, 10037, 10036, 10035, 10001, 10208                                    |
| <b>M</b> M Electronic | 10009, 10037, 10109, 10163, 10195, 10217, 10287, 10343, 10346, 10374, 10480, 10512, 10634, 10661, 10714  |
| Madison               | 10037  |
| MAG                   | 11498  |
| Magnadyne             | 10054, 10163   |
| Magnafon              | 10073  |
| Magnasonic            | 10054, 10000, 10156, 10093, 10030, 10092, 10109  |

|                |   |
|----------------|---|
| Magnavox       | 10047, 11454, 10054, 10154, 10000, 10250, 10051, 10180, 10060, 10030, 10171, 10092, 10706, 11944, 11904, 11755, 11254, 10802, 10780, 10011, 10035, 10037, 10036 |
| Magnum         | 10037, 10648, 10714, 10715  |
| Majestic       | 10017   |
| Mandor         | 10264   |
| Manesth        | 10035, 10037, 10217, 10264  |
| Manhattan      | 10037, 10668, 10778, 10876, 11037, 11267  |
| Marantz        | 11454, 10054, 10030, 10037, 10556, 10704, 10855   |
| Mark           | 10009, 10037, 10217, 10374, 10714, 10715  |
| Master's       | 10499   |
| Mastro         | 10053, 10706, 10698, 10780  |
| Masuda         | 10009, 10037, 10217, 10218, 10264, 10371  |
| Matsui         | 11037, 10744, 10714, 10556, 10487, 10455, 10443, 10433, 10371, 10352, 10335, 10217, 10208, 10195, 10163, 10037, 10036, 10035, 10011, 10009                      |
| Matsushita     | 10250, 10051, 10650   |
| Maxdorf        | 10773   |
| Maxent         | 11755, 11756  |
| Maxim          | 11556, 11982  |
| MCE            | 10009   |
| Meck           | 10698   |
| Mediator       | 10037, 10556  |
| Medion         | 10037, 10512, 10556, 10668, 10698, 10714, 10808, 10880, 11037, 11137, 11248, 11900  |
| Megapower      | 10700   |
| Megas          | 10610   |
| Megatron       | 10047, 10178, 10145, 10009  |
| MEI            | 11037   |
| Meile          | 10264, 10817  |
| Memorex        | 10154, 10250, 10463, 10180, 10150, 10060, 10178, 10030, 10009, 10035, 10037, 10195, 10877, 11037, 11911   |
| Memphis        | 10009   |
| Mercury        | 10060, 10001, 10009, 10037  |
| Mermaid        | 10037   |
| Metronic       | 10625   |
| Metz           | 10037, 10195, 10367, 10388, 10447, 10587, 10668, 10746, 11163   |
| MGA            | 10150, 10178, 10030, 10218, 10374   |
| MGN Technology | 10178   |
| Micro Genius   | 10150   |
| Micromaxx      | 10037, 10668, 10714, 10808, 11037   |
| Microstar      | 10808   |
| MicroTEK       | 10820, 10860  |
| Midland        | 10047, 10017, 10051   |
| Mikomi         | 11037, 11149  |

|            |  |
|------------|--|
| Minato     | 10037, 10556   |
| Minerva    | 10070, 10108, 10195, 10487   |
| Minoka     | 10037  |
| Mirror     | 11900  |
| Mitsubishi | 10154, 10250, 10093, 10236, 10180, 11250, 10150, 10178, 10030, 11917, 11037, 10836, 10817, 10556, 10512, 10195, 10108, 10037, 10036, 10011                             |
| Mivar      | 10217  |
| Monaco     | 10009  |
| Monivision | 10700, 10843   |
| Morgan's   | 10037  |
| Motorola   | 10054, 10051, 10093, 10150   |
| MTC        | 10180, 10060, 10030, 10092, 10011, 10370, 10512  |
| MTlogic    | 10714  |
| Mudan      | 10051, 10009, 10208, 10226, 10264, 10817   |
| Multitec   | 10037, 10486, 10668, 11037, 11556  |
| Multitech  | 10180, 10009, 10037, 10217, 10264, 10370, 10486  |
| Murphy     | 10163  |
| Musikland  | 10218  |
| Mx Onda    | 11498  |
| Myriad     | 10556  |
| NAD        | 10156, 10178, 10166, 10037, 10361, 10866, 11156  |
| Naiko      | 10037, 10606, 11982  |
| Nakimura   | 10037, 10374   |
| Nanbao     | 10009, 10264   |
| Nansheng   | 10264, 10817   |
| Narita     | 11982  |
| NAT        | 10226  |
| National   | 10051, 10208, 10226, 10508   |
| NEC        | 10047, 10154, 10156, 10051, 10053, 10178, 10030, 11704, 11270, 11170, 10817, 10704, 10661, 10653, 10508, 10499, 10455, 10374, 10264, 10217, 10170, 10036, 10011, 10009 |
| Neckermann | 10037, 10200, 10327, 10370, 10418, 10556   |
| NEI        | 10037, 10163, 10371  |
| Neovia     | 10865, 10876, 11371  |
| Netsat     | 10037  |
| NetTV      | 11755  |
| Neufunk    | 10009, 10037, 10218, 10556, 10610, 10714   |
| New Tech   | 10009, 10037, 10217, 10343, 10556  |
| New World  | 10218  |
| Newwave    | 10093, 10178, 10092, 10009   |
| Nikkai     | 10009, 10035, 10036, 10037, 10163, 10217, 10218, 10264   |
| Nikkei     | 10714  |
| Nikko      | 10178, 10030, 10092  |
| Nikkodo    | 10178, 10030, 10092  |

|                  |   |
|------------------|---|
| Nishi            | 10030   |
| Noblisko         | 10070   |
| Nogamatic        | 10109   |
| Nokia            | 10163, 10208, 10346, 10361, 10374, 10480, 10548, 10606, 10610, 10631                                    |
| Norcent          | 10748, 10824  |
| Nordic           | 10217   |
| Nordmende        | 10037, 10109, 10195, 10287, 10343, 10560, 10714   |
| Normerel         | 10037   |
| Novatronic       | 10037, 10374  |
| NTC              | 10092   |
| Nu-Tec           | 10455, 10698, 10820   |
| Nyon             | 10000   |
| <b>O</b> Oceanic | 10163, 10208, 10361, 10548  |
| Odeon            | 10264   |
| Okano            | 10009, 10037, 10264, 10370  |
| Olevia           | 11144, 11240, 11331, 11610  |
| Omega            | 10264   |
| Omni             | 10748, 10698, 10780, 10872  |
| Onida            | 10053, 11253  |
| Onimax           | 10714   |
| Onwa             | 10180, 10218, 10371, 10433, 10602   |
| Opera            | 10037   |
| Optimus          | 10154, 10250, 10093, 10180, 10150, 10178, 10030, 10166, 10650   |
| Optoma           | 10887   |
| Optonica         | 10093   |
| Orbit            | 10037   |
| Orcom            | 11504   |
| Orion            | 10017, 10236, 10463, 10180, 10178, 11463, 10011, 10037, 10264, 10443, 10556, 10714, 10880, 11196, 11911 |
| Orline           | 10037, 10218  |
| Ormond           | 10668, 11037  |
| Osaki            | 10037, 10217, 10218, 10264, 10374, 10556  |
| Osio             | 10037   |
| Oso              | 10218   |
| Osume            | 10036, 10037, 10218   |
| Otic             | 11498   |
| Otto Versand     | 10093, 10036, 10037, 10109, 10195, 10217, 10226, 10343, 10361, 10512, 10556                             |
| <b>P</b> Pace    | 10092   |
| Pacific          | 10037, 10443, 10556, 10714, 11037, 11137  |
| Palladium        | 10037, 10163, 10200, 10217, 10327, 10370, 10418, 10556, 10714, 11137                                    |
| Palsonic         | 10001, 10037, 10217, 10218, 10264, 10418, 10698, 10773, 10778, 11196, 11269, 11904                      |
| Panama           | 10009, 10037, 10217, 10264  |
| Panashiba        | 10001   |



|                 |  |
|-----------------|--|
| Panasonic       | 10054, 10000, 10156, 10250, 10051, 10236, 10030, 11947, 11946, 11941, 11480, 11310, 11291, 11271, 10853, 10650, 10548, 10508, 10367, 10361, 10226, 10208, 10163, 10108, 10037, 10035 |
| Panavision      | 10037  |
| Panda           | 10051, 10706, 10009, 10208, 10226, 10264, 10508, 10698, 10780, 10817, 10821  |
| Pathe Cinema    | 10163  |
| Pathe Marconi   | 10109  |
| Pausa           | 10009  |
| Paxonic         | 10060, 10030   |
| PCE             | 10156, 10060   |
| Penney          | 10047, 10000, 10156, 10250, 10051, 10060, 10178, 10030, 10035, 10036, 10037, 10070, 10108, 11347   |
| Perdio          | 10037, 10163   |
| Perfekt         | 10037  |
| Petters         | 11523  |
| Philco          | 10054, 10451, 10463, 10180, 10178, 10030, 10145, 11661, 10037, 10074, 10163, 10370, 10418  |
| Philharmonic    | 10217  |
| Philips         | 11454, 10054, 10017, 10000, 10051, 10178, 10030, 10171, 10092, 11961, 11756, 11254, 10690, 10556, 10512, 10374, 10361, 10343, 10200, 10108, 10037, 10009                             |
| Phocus          | 10714  |
| Phoenix         | 10037, 10163, 10370, 10486   |
| Phonola         | 10037, 10556   |
| Pilot           | 10051, 10060, 10178, 10030, 10706, 10011   |
| Pioneer         | 10166, 10011, 10037, 10109, 10163, 10170, 10287, 10361, 10370, 10486, 10512, 10679, 10760, 10866, 11260  |
| Pionier         | 10370, 10486, 11556  |
| Plantron        | 10009, 10037, 10264  |
| Playsonic       | 10037, 10217, 10714, 10715   |
| Polaroid        | 10765, 10865, 11276, 11316, 11341, 11498, 11523  |
| Poppy           | 10009  |
| Portland        | 10451, 10092, 10374  |
| Powerpoint      | 10037, 10487, 10698  |
| Prandoni-Prince | 10361  |
| Precision       | 10236, 10180, 10217  |
| Premier         | 10009, 10264   |
| President       | 10860  |
| Prima           | 10761, 10009, 10264, 10783, 10815, 10817, 11269, 11933   |
| Princeton       | 10700  |
| Prinston        | 11037  |
| Prinz           | 10361  |
| Prism           | 10250, 10051   |

|              |  |
|--------------|--|
| Profex       | 10009, 10163, 10361  |
| Profi        | 10009  |
| Profilo      | 11556  |
| Profitronic  | 10037  |
| Proline      | 10037, 10073, 10625, 10634, 11037  |
| Proscan      | 11447, 10047, 11347, 11922   |
| Proscop      | 10156  |
| Prosonic     | 10037, 10217, 10370, 10371, 10374, 10668, 10714  |
| Protec       | 10009, 10037, 10217, 10264   |
| Protech      | 10009, 10037, 10217, 10264, 10418, 10486, 10668, 11037   |
| Proton       | 10178, 10030, 10001, 10009   |
| Proview      | 11498  |
| ProVision    | 10037, 10556, 10714, 11037   |
| Pulsar       | 10017, 10092   |
| Pulser       | 10178, 10092   |
| Pvision      | 10876, 11191   |
| Pye          | 10037, 10374, 10556  |
| Pymi         | 10009  |
| Q            |  |
| Qingdao      | 10051, 10208, 10226, 10264, 10817  |
| Quadral      | 10051, 10218   |
| Quartz       | 10150, 10178   |
| Quasar       | 10250, 10051, 10009, 10035, 10650, 10865   |
| Quelle       | 10011, 10037, 10070, 10074, 10109, 10195, 10200, 10327, 10361, 10512, 10668, 11037   |
| Questa       | 10036  |
| Questar      | 10036  |
| R            |  |
| R-Line       | 10037  |
| Rabbit       | 10047  |
| Radialva     | 10163, 10218   |
| Radiola      | 10037, 10217, 10556  |
| Radiomarelli | 10037  |
| RadioShack   | 10047, 10154, 10180, 10150, 10178, 10030, 10037, 11904   |
| Radiotone    | 10009, 10037, 10264, 10370, 10418, 10648, 10668, 11037   |
| Rank         | 10070  |
| Rank Arena   | 10036, 10602   |
| RBM          | 10070  |
| RCA          | 11447, 10047, 11454, 10054, 10000, 10051, 10093, 10178, 10030, 10092, 11958, 11953, 11948, 11922, 11917, 11547, 11347, 11247, 11147, 11047, 10679, 10625, 10560, 10090 |
| Realistic    | 10047, 10154, 10180, 10150, 10178, 10030   |
| Recor        | 10037, 10418   |
| Rectiligne   | 10037  |
| Rediffusion  | 10036, 10163, 10346, 10361, 10548  |
| Redstar      | 10037  |
| Reflex       | 10037, 10668, 11037  |
| Relisys      | 10865, 10876, 10877, 11207, 11298  |

|           |  |
|-----------|--|
| Remotec   | 10250, 10093, 10145, 10171, 10037  |
| Reoc      | 10714  |
| Revov     | 10037  |
| Rex       | 10163, 10264   |
| RFT       | 10037, 10264   |
| Rinex     | 10773  |
| Roadstar  | 10009, 10037, 10218, 10264, 10418, 10668, 10714, 11037, 11900  |
| Rolson    | 11371  |
| Rover     | 10036, 10877   |
| Rowa      | 10748, 10009, 10037, 10264, 10587, 10698, 10712, 10817   |
| Royal Lux | 10335, 10370   |
| Runco     | 10017, 10060, 10030  |
| Ruyi      | 10817  |
| S         |  |
| Saba      | 10250, 10109, 10163, 10287, 10335, 10343, 10361, 10498, 10548, 10560, 10625, 10714   |
| Sagem     | 10455, 10610, 10618  |
| Saige     | 10009, 10817   |
| Saisho    | 10009, 10011, 10163, 10217, 10264  |
| Saivod    | 10037, 10668, 10712, 11037, 11163, 11556, 11982  |
| Sakai     | 10163  |
| Sakyno    | 10455  |
| Salora    | 10163, 10208, 10361, 10480, 10548, 10631   |
| Salsa     | 10335  |
| Sampo     | 10047, 10154, 10093, 10178, 10030, 10171, 10092, 10009, 10036, 10650, 10700, 11755, 11756  |
| Samsung   | 10047, 10054, 10017, 10154, 10156, 10093, 10060, 10812, 10702, 10178, 10030, 10092, 10814, 10766, 10718, 10618, 10587, 10817, 10821, 11060, 11249, 11312, 11903, 11959, 10556, 10371, 10370, 10362, 10264, 10226, 10217, 10208, 10163, 10090, 10037, 10036, 10035, 10009 |
| Sandra    | 10217  |
| Sanjian   | 10264  |
| Sanky     | 10060, 10030   |
| Sansui    | 10463, 10060, 10030, 10706, 10037, 10371, 10455, 10602, 10714, 10861, 11371, 11537, 11904, 11911   |
| Santon    | 10009  |
| Sanyo     | 10047, 10054, 10154, 10000, 10156, 10463, 10180, 10145, 10171, 11755, 11208, 10704, 10508, 10370, 10264, 10217, 10208, 10170, 10163, 10108, 10088, 10037, 10036, 10011, 10009  |
| Sanyong   | 10037  |
| Sanyuan   | 10093, 10009, 10817  |
| Saville   | 10060  |

|                 |  |
|-----------------|--|
| SBR             | 10037, 10556   |
| Sceptre         | 11217  |
| Schaub Lorenz   | 10361, 10374, 10486, 10548, 10606, 10714, 11191  |
| Schneider       | 11982, 11904, 11137, 11037, 10714, 10668, 10648, 10556, 10394, 10371, 10361, 10352, 10343, 10218, 10217, 10163, 10070, 10037               |
| Scotch          | 10178  |
| Scotland        | 10163  |
| Scott           | 10236, 10180, 10178, 10030   |
| Sears           | 10047, 10054, 10017, 10154, 10000, 10156, 10051, 10093, 10060, 10053, 10178, 10030, 10171, 10166, 10035, 10036, 10037, 10001, 10208, 11904 |
| Seaway          | 10634  |
| Seelver         | 11037  |
| SEG             | 10009, 10036, 10037, 10217, 10218, 10264, 10362, 10487, 10668, 11037, 11163  |
| SEI             | 10037, 10163   |
| Sei-Sinudyne    | 10037  |
| Seleco          | 10163, 10264, 10346, 10362, 10371  |
| Semivox         | 10180  |
| Semp            | 10156  |
| Sencora         | 10009  |
| Sentra          | 10035  |
| Serino          | 10093, 10455, 10610  |
| Shancha         | 10264, 10817   |
| Shanghai        | 10009, 10208, 10226, 10264, 10817  |
| Shaofeng        | 10145, 10817   |
| Sharp           | 10054, 10093, 10180, 10053, 10030, 10009, 10036, 10200, 10650, 10653, 10668, 11193, 11393, 11917   |
| Shen Ying       | 10092, 10009   |
| Shencai         | 10145, 10009, 10264  |
| Sheng Chia      | 10093, 10236, 10009  |
| Shenyang        | 10009, 10264, 10817  |
| Sherwood        | 10009  |
| Shintoshi       | 10037  |
| Shivaki         | 10178, 10037, 10374, 10443, 10556  |
| Show            | 10009, 10418   |
| Siarem          | 10163  |
| Siemens         | 10145, 10037, 10195, 10200, 10327  |
| Siera           | 10037, 10556   |
| Siesta          | 10370  |
| Signature       | 10047, 10093, 10030  |
| Silva           | 10037, 10361, 10648  |
| Silva Schneider | 10037, 11556   |
| Silvano         | 10587  |
| Silver          | 10036, 10361, 10455, 10715   |
| SilverCrest     | 11037  |

|                     |  |
|---------------------|--|
| Simpson             | 10178, 10030, 10011  |
| Singer              | 10060, 10092, 10009, 10037, 10335, 10371, 10433, 11537   |
| Sinotec             | 10773  |
| Sinudyne            | 10037, 10163, 10361  |
| Skantic             | 10163  |
| SKY                 | 10037, 10880, 11504  |
| Sky Brazil          | 10880  |
| Sky-North           | 10037  |
| Skygiant            | 10180  |
| Skyworth            | 10748, 10009, 10037, 10264, 10698, 10805, 10817, 11115   |
| Sliding             | 10865, 10880   |
| SLX                 | 10668  |
| Smaragd             | 10487  |
| Soemtron            | 10865, 11298   |
| Solar Drape         | 10000  |
| Solavox             | 10037, 10163, 10361, 10548   |
| Sole                | 10813  |
| Sonawa              | 10218  |
| Songba              | 10009  |
| Soniko              | 10037  |
| Sonitron            | 10208, 10217, 10370  |
| Sonneclair          | 10037  |
| Sonoko              | 10009, 10037, 10217, 10264   |
| Sonolor             | 10163, 10208, 10361, 10548   |
| Sontec              | 10009, 10037, 10370  |
| Sony                | 10017, 10154, 11100, 10000, 10150, 10053, 10011, 10036, 10037, 10074, 10353, 10650, 11505, 11651, 11751, 11904 |
| Sound & Vision      | 10218, 10374   |
| Soundesign          | 10180, 10178   |
| Soundwave           | 10037, 10418, 10715  |
| Sova                | 11952  |
| Sowa                | 10156, 10051, 10060, 10178, 10092, 10036, 10226  |
| Soyea               | 10773  |
| Spectra             | 10009  |
| Spectravision       | 10156, 10178   |
| Spectroniq          | 11498  |
| Squareview          | 10171  |
| SR2000              | 10154, 10171   |
| SSangyong           | 10009  |
| SSS                 | 10180  |
| Staksonic           | 10009  |
| Standard            | 10009, 10037, 10217, 10218, 10374, 11037   |
| Standard Components | 10009, 10218   |
| Starlite            | 10236, 10180, 10009, 10037, 10163, 10264   |
| Stenway             | 10218  |
| Stern               | 10163, 10264   |
| Stevison            | 11982  |
| Strato              | 10009, 10037, 10264  |

|                   |   |
|-------------------|---|
| Strong            | 11149, 11163  |
| Studio Experience | 10843   |
| Stylandia         | 10217   |
| Sunkai            | 10218, 10455, 10487, 10610, 10865   |
| Sunstar           | 10009, 10037, 10264, 10371  |
| Sunwatt           | 10455   |
| Sunwood           | 10037   |
| Superla           | 10217   |
| Superscan         | 10093, 10864, 11944   |
| Supersonic        | 10009, 10208, 10455, 10805  |
| SuperTech         | 10009, 10037, 10218, 10556  |
| Supra             | 10178, 10009, 10374   |
| Supreme           | 10000   |
| Susumu            | 10218, 10287, 10335   |
| Sutron            | 10009   |
| SV2000            | 10054   |
| SVA               | 10748, 10587, 10865, 10870, 10871, 10872  |
| Svasa             | 10455   |
| Swisstec          | 10880, 11504  |
| Sydney            | 10217   |
| Sylvania          | 10047, 10054, 10154, 10000, 10051, 10178, 10030, 10171, 10092, 10036, 10037, 10876, 11271, 11904, 11944                             |
| Symphonic         | 10000, 10180, 10178, 10171, 11904, 11944  |
| Synco             | 10000, 10451, 10093, 10060, 10178, 10092, 10036   |
| Syntax            | 11144, 11240, 11331   |
| Sysline           | 10037   |
| T+A               | 10447   |
| Tacico            | 10178, 10092, 10009   |
| Tai Yi            | 10009   |
| Taishan           | 10009, 10374, 10817   |
| Tandberg          | 10109, 10361, 10367   |
| Tandy             | 10093, 10163, 10217, 10218  |
| Targa             | 11371   |
| Tashiko           | 10092, 10036, 10163, 10170, 10217, 10650  |
| Tatung            | 10054, 10154, 10000, 10156, 10051, 10060, 10037, 10036, 10011, 10009, 10217, 11156, 11191, 11248, 11254, 11371, 11556, 11756        |
| TCL               | 10706, 10698, 11027, 11537  |
| TCM               | 10714, 10808  |
| Teac              | 10154, 10178, 10171, 10706, 11755, 11149, 11037, 10714, 10712, 10698, 10668, 10512, 10455, 10418, 10264, 10217, 10170, 10037, 10009 |
| Tec               | 10009, 10037, 10163, 10217, 10335   |
| Tech Line         | 10037, 10668, 11163   |
| Techica           | 10218   |
| Technica          | 11982   |

|                        |   |
|------------------------|---|
| Technics               | 10054, 10250, 10051, 10226, 10556, 10650  |
| TechniSat              | 10556, 11267  |
| Technisson             | 10714   |
| Technosonic            | 10499, 10556  |
| Technovox              | 10030, 10217  |
| Techview               | 10847   |
| Techwood               | 10250, 10051, 10060, 11163  |
| Tecnimagen             | 10556   |
| Teco                   | 10051, 10093, 10178, 10092, 10009, 10036, 10218, 10264, 10653, 11040  |
| Tedelex                | 10009, 10208, 10217, 10418, 10606, 10698, 11537   |
| Teiron                 | 10009   |
| Tek                    | 10820   |
| Teknika                | 10054, 10463, 10180, 10150, 10060, 10178, 10092   |
| Tele System Electronic | 10876   |
| Teleavia               | 10287, 10343  |
| Telecolor              | 10017   |
| Telecor                | 10037, 10163, 10217, 10218, 10394   |
| Telefunken             | 10702, 11504, 10821, 10820, 10819, 10714, 10712, 10698, 10625, 10587, 10560, 10498, 10486, 10346, 10343, 10335, 10287, 10109, 10074, 10073, 10037 |
| Tелефusion             | 10037   |
| Telegazi               | 10037, 10163, 10218, 10264  |
| Telemeister            | 10037   |
| Telesonic              | 10037   |
| Telestar               | 10009, 10037, 10556   |
| Teletech               | 10009, 10037, 10668, 11037  |
| Teleton                | 10036, 10217  |
| Televideon             | 10163   |
| Television             | 10037   |
| Tempest                | 10009, 10264, 10455   |
| Tennessee              | 10037   |
| Tensai                 | 10009, 10037, 10217, 10218, 10371, 10374, 10715, 11037  |
| Tenson                 | 10009   |
| Tera                   | 10030, 10092  |
| Tevion                 | 10037, 10556, 10648, 10668, 10714, 10808, 11037, 11137, 11248, 11298, 11498, 11556  |
| Textet                 | 10009, 10217, 10218, 10374  |
| Texla                  | 10780   |
| ThemeScene             | 10887   |
| Thomas                 | 10047, 10178, 10001, 11904  |
| Thomson                | 11447, 10047, 10037, 10109, 10287, 10335, 10343, 10560, 10625   |
| Thorn                  | 10035, 10036, 10037, 10073, 10074, 10109, 10163, 10264, 10335, 10343, 10361, 10499, 10512   |
| Thorn-Ferguson         | 10073, 10335, 10343, 10499  |

|                  |   |
|------------------|---|
| Tiane            | 10093, 10817  |
| Tiny             | 11269   |
| TMK              | 10236, 10180, 10178   |
| TML              | 11756   |
| TNCi             | 10017   |
| Tobishi          | 10218   |
| Tobo             | 10748, 10009, 10264   |
| Tocom            | 10156   |
| Tokai            | 10009, 10037, 10163, 10217, 10374, 10668, 11037   |
| Tokaido          | 11037   |
| Tokyo            | 10035   |
| Tomashi          | 10218   |
| Tongguang        | 10264   |
| Tongtel          | 10587, 10780  |
| Topline          | 10668, 11037  |
| Toshiba          | 10154, 11256, 10156, 10150, 11265, 10060, 11145, 10145, 10166, 11037, 11156, 11163, 11164, 11356, 11508, 11556, 11656, 11704, 11945, 11971, 10845, 10821, 10718, 10650, 10618, 10508, 10264, 10217, 10195, 10109, 10070, 10036, 10035, 10011, 10009 |
| Totevision       | 10051   |
| Towada           | 10217   |
| Toyoda           | 10009, 10264, 10371   |
| Toyomenka        | 10178   |
| Trakton          | 10217, 10264  |
| Trans Continens  | 10037, 10217, 10668, 11037  |
| TRANS-continents | 10556, 10865  |
| Transonic        | 10009, 10037, 10264, 10418, 10455, 10512, 10587, 10698, 10712, 10780  |
| Triad            | 10218, 10556  |
| Trident          | 10217   |
| Trio             | 11498   |
| Tristar          | 10218, 10264  |
| Triumph          | 10037, 10346, 10556   |
| Truetone         | 10250, 10051  |
| Tuntex           | 10030, 10092, 10009   |
| TVS              | 10463   |
| TVTEXT 95        | 10556   |
| Uher             | 10037, 10370, 10374, 10418, 10480, 10486  |
| Ultra            | 10092   |
| Ultravox         | 10037, 10163, 10374   |
| Unic Line        | 10037, 10455  |
| United           | 10037, 10587, 10714, 10715, 11037, 11982  |
| Universal        | 10047, 10037  |
| Universum        | 11163, 11037, 10668, 10631, 10618, 10512, 10480, 10418, 10370, 10362, 10361, 10346, 10327, 10264, 10217, 10200, 10195, 10170, 10109, 10074, 10070, 10037, 10036, 10011, 10009   |

|                 |  |
|-----------------|--|
| Univox          | 10037, 10163   |
| V               | 10864, 10885, 11755, 11756   |
| V2max           | 10865  |
| V7 Videoseven   | 10880, 11217, 11755  |
| Vector Research | 10030  |
| Vestel          | 10037, 10217, 10668, 11037, 11163  |
| Vexa            | 10009, 10037   |
| Victor          | 10250, 10053, 10036, 10650, 10653  |
| Videocon        | 10508  |
| Videologic      | 10218  |
| Videologique    | 10217, 10218   |
| Videomac        | 10009  |
| VideoSystem     | 10037  |
| Videotechnic    | 10217, 10374   |
| Videoton        | 10163  |
| Vidikron        | 10054  |
| Vidtech         | 10178, 10036   |
| Viewpia         | 10876  |
| Viewsonic       | 10857, 10864, 10885, 11330, 11578, 11627, 11755  |
| Viking          | 10060  |
| Viore           | 11207  |
| Vision          | 10037, 10217, 10264  |
| Vizio           | 10864, 10885, 11755, 11756, 11758  |
| Vortec          | 10037  |
| Voxson          | 10178, 10037, 10163, 10418   |
| Waltham         | 10037, 10109, 10217, 10418, 10443, 10668, 11037  |
| Wards           | 10047, 10054, 10017, 10154, 10000, 10156, 10051, 10093, 10236, 10180, 10060, 10178, 10030, 10166, 11347, 11156, 11147, 10866, 10195, 10001, 10037, 10035 |
| Warumaia        | 10374, 10661   |
| Watson          | 10009, 10037, 10163, 10218, 10394, 10668, 10714, 11037   |
| Watt Radio      | 10163  |
| Waycon          | 10156  |
| Wega            | 10036, 10037   |
| Wegavox         | 10009  |
| Weipai          | 10009  |
| Welltech        | 10714  |
| Weltblick       | 10217  |
| Welton          | 10178  |
| Weltstar        | 11037  |
| Westinghouse    | 10000, 10451, 10885, 10889, 11282, 11577   |
| Wharfedale      | 10037, 10556, 10860, 11556   |
| White           | 10451, 10236, 10463, 10037, 10623, 10889, 11909  |
| Windsor         | 10668, 11037   |
| Windy Sam       | 10556  |
| Wintel          | 10714  |
| World           | 10451, 10236, 10463, 10180   |

|                 |   |
|-----------------|---|
| World-of-Vision | 10865, 10877, 10880, 11217, 11298   |
| Worldview       | 10455   |
| X-View          | 11191   |
| Xenius          | 10634, 10661  |
| Xiahua          | 10009, 10264, 10698, 10773, 10817   |
| Xianghai        | 10009   |
| Xiangyang       | 10264   |
| Xiangyu         | 10009   |
| Xihu            | 10264, 10817  |
| Xingfu          | 10009   |
| Xinghai         | 10264   |
| XLogic          | 10698, 10860  |
| Xoceco          | 11064   |
| Xoro            | 11196, 11217  |
| XR-1000         | 10154, 10180, 10171   |
| Xrypton         | 10037   |
| Yamaha          | 10030, 10650, 11576   |
| Yamishi         | 10037, 10217, 10218, 10455  |
| Yapshie         | 10250   |
| Yingge          | 10009   |
| Yokan           | 10037   |
| Yoko            | 10009, 10037, 10217, 10218, 10264, 10370  |
| Yonggu          | 10009   |
| Yorx            | 10030, 10218  |
| Youlanasi       | 10817   |
| Yousida         | 10009   |
| Yuhang          | 10009   |
| Zanussi         | 10163, 10217, 10264   |
| Zenith          | 10047, 10017, 10000, 10093, 10463, 11265, 10812, 10178, 10030, 11145, 10145, 10171, 10092, 10037, 11904, 11909, 11911 |
| ZhuHai          | 10009, 10374  |

## TV/DVD Combination ※2, ※4

※2

|                        |                     |
|------------------------|---------------------|
| <b>A</b> Advent        | 11933               |
| Akai                   | 11675               |
| Akura                  | 11982               |
| Alba                   | 11037               |
| Amstrad                | 11982               |
| Apex Digital           | 11943               |
| Audiovox               | 11937, 11951, 11952 |
| Axion                  | 11937, 11958        |
| <b>B</b> Black Diamond | 11037               |
| Bush                   | 10698, 11037, 11900 |
| <b>C</b> Centrum       | 11037               |
| Crown                  | 11037               |
| <b>D</b> D-Vision      | 11982               |
| Denver                 | 10587               |





|          |           |       |
|----------|-----------|-------|
| <b>S</b> | Sharp     | 11917 |
|          | Sylvania  | 11944 |
|          | Symphonic | 11944 |
| <b>T</b> | Toshiba   | 11945 |

※3

|          |       |       |
|----------|-------|-------|
| <b>S</b> | Sharp | 20807 |
|----------|-------|-------|

※4

|          |           |              |
|----------|-----------|--------------|
| <b>A</b> | Akai      | 30899        |
| <b>E</b> | Emerson   | 30821        |
|          | ESA       | 30821        |
| <b>M</b> | Magnavox  | 30821        |
| <b>P</b> | Panasonic | 31362, 31462 |
| <b>R</b> | RCA       | 31132        |
| <b>S</b> | Sharp     | 30630        |
|          | Superscan | 30821        |
|          | Sylvania  | 30821        |
|          | Symphonic | 30821        |
| <b>T</b> | Toshiba   | 31045        |

## VCR

|          |                |  |
|----------|----------------|--|
| <b>A</b> | A-Mark         | 20037, 20240, 20000, 20278, 20046                                    |
|          | ABS            | 21972  |
|          | Admiral        | 20060, 20048, 20039, 20047, 20104, 20121, 20209, 20479               |
|          | Adventura      | 20037, 20240, 20000  |
|          | Aiko           | 20278  |
|          | Aim            | 20278, 20348, 20642  |
|          | Aiwa           | 20037, 20032, 20000, 20209, 20041, 20348, 20352, 20479, 20742, 21137 |
|          | Akai           | 20037, 20240, 20041, 20106, 20315, 20348, 20352, 20642               |
|          | Akura          | 20041  |
|          | Alba           | 20081, 20000, 20209, 20278, 20315, 20348, 20352                      |
|          | Alienware      | 21972  |
|          | Allegro        | 20039, 21137   |
|          | Allorgan       | 20240  |
|          | Allstar        | 20081  |
|          | America Action | 20278  |
|          | American High  | 20035, 20081   |
|          | Amoisonic      | 20479  |
|          | Amstrad        | 20000, 20278   |
|          | Anam           | 20162, 20037, 20240, 20278, 20226, 20480                             |
|          | Anam National  | 20162, 20226, 21162, 21562   |
|          | Ansonic        | 20000  |
|          | Aristona       | 20081  |
|          | ASA            | 20037, 20081   |
|          | Asha           | 20240  |
|          | Astra          | 20035, 20240   |
|          | Asuka          | 20037, 20081, 20000, 20038   |

|  |            |                            |
|--|------------|----------------------------|
|  | Audiolab   | 20081                      |
|  | Audiosonic | 20278                      |
|  | Audiovox   | 20037, 20278, 20038        |
|  | Avis       | 20000                      |
|  | AVP        | 20000, 20352               |
|  | Awa        | 20037, 20043, 20278, 20642 |

**B**

|  |                     |   |
|--|---------------------|---|
|  | Baird               | 20000, 20104, 20041, 20278, 20046, 20106                      |
|  | Basic Line          | 20104, 20278, 20046   |
|  | Beaumarck           | 20240   |
|  | Beko                | 20104   |
|  | Bell & Howell       | 20035, 20048, 20039, 20000, 20104, 20046, 20479               |
|  | Bestar              | 20278   |
|  | Black Diamond       | 20642   |
|  | Black Panther       | 20278   |
|  | Blaupunkt           | 20162, 20081, 20226   |
|  | Blue Sky            | 20037, 20209, 20278, 20348, 20352, 20480, 20642, 20742, 21137 |
|  | BPL                 | 20046   |
|  | Brandt              | 20041, 20320  |
|  | Brandt Electronique | 20041   |
|  | Brinkmann           | 20209, 20348  |
|  | Broksonic           | 20184, 20121, 20209, 20002, 20348, 20479, 21479               |
|  | Bush                | 20081, 20000, 20209, 20278, 20315, 20348, 20352, 20642, 20742 |

**C**

|  |            |  |
|--|------------|--|
|  | Calix      | 20037  |
|  | Candle     | 20037, 20038   |
|  | Canon      | 20035  |
|  | Capehart   | 20002  |
|  | Carena     | 20081, 20209   |
|  | Carrefour  | 20045  |
|  | Carrera    | 20240  |
|  | Carver     | 20035, 20081   |
|  | Casio      | 20000  |
|  | Cathay     | 20278  |
|  | CCE        | 20278  |
|  | CGE        | 20000, 20041   |
|  | Changhong  | 20048, 20081   |
|  | Cimline    | 20209  |
|  | Cineral    | 20278  |
|  | CineVision | 21137  |
|  | Citizen    | 20035, 20037, 20240, 20000, 20209, 20278, 20479, 21278 |
|  | Classic    | 20037  |
|  | Clatronic  | 20000, 21593   |
|  | Colortyme  | 20060, 20035, 20045, 20278                             |
|  | Colt       | 20000  |
|  | Combitech  | 20352  |
|  | Condor     | 20278  |
|  | Craig      | 20037, 20047, 20240                                    |
|  | Criterion  | 20000  |

**D**

|  |               |   |
|--|---------------|---|
|  | Crosley       | 20035, 20081, 20000   |
|  | Crown         | 20037, 20278, 20480   |
|  | Curtis Mathes | 20060, 20035, 20162, 20240, 20000, 20041, 20278, 20432, 21035               |
|  | Cybernex      | 20240   |
|  | CyberPower    | 21972   |
|  | Cyrus         | 20081   |
|  | Daewoo        | 20037, 20045, 20104, 20209, 20278, 20046, 20352, 20637, 20642, 21137, 21278 |

|  |           |  |
|--|-----------|--|
|  | Dansai    | 20278                                    |
|  | Dantax    | 20352                                    |
|  | Daytron   | 20037, 20278                             |
|  | De Graaf  | 20048, 20081, 20042, 20104, 20046        |
|  | Decca     | 20081, 20000, 20067, 20209, 20041, 20352 |
|  | Degraff   | 20048, 20081, 20042, 20104               |
|  | Deitron   | 20278                                    |
|  | Dell      | 21972                                    |
|  | Denon     | 20081, 20042                             |
|  | Derwent   | 20041                                    |
|  | Diamant   | 20037                                    |
|  | Diamond   | 20348                                    |
|  | Digitor   | 20642                                    |
|  | DirecTV   | 20739                                    |
|  | Domland   | 20209                                    |
|  | DSE       | 20642                                    |
|  | Dual      | 20081, 20000, 20041, 20278, 20348        |
|  | Dumont    | 20081, 20000, 20104                      |
|  | Durabrand | 20039, 20038, 20642                      |
|  | Dynatech  | 20240, 20000                             |

**E**

|  |              |  |
|--|--------------|--|
|  | Elbe         | 20278, 20038                             |
|  | Electrohome  | 20060, 20037, 20240, 20000, 20043, 20209 |
|  | Electroponic | 20037                                    |
|  | Elin         | 20240                                    |
|  | Elta         | 20278                                    |
|  | Emerald      | 20184, 20121                             |
|  | Emerex       | 20032                                    |

|  |          |  |
|--|----------|--|
|  | Emerson  | 20035, 20037, 20184, 20039, 20240, 20045, 20000, 20121, 20043, 20209, 20002, 20278, 20348, 20479, 20637, 21278, 21479, 21593 |
|  | ESA      | 21137  |
|  | ESC      | 20240, 20278   |
|  | EuroLine | 21593  |

**F**

|  |           |  |
|--|-----------|--|
|  | Ferguson  | 20000, 20041, 20278, 20320, 20348                                    |
|  | Fidelity  | 20240, 20000, 20352, 20432   |
|  | Finlandia | 20037, 20048, 20081, 20000, 20042, 20104, 20043, 20046, 20106, 20226 |
|  | Finlux    | 20081, 20000, 20042, 20104   |

**G**

|  |                 |   |
|--|-----------------|---|
|  | Firstline       | 20037, 20045, 20042, 20043, 20209, 20278, 20348, 20480, 21137 |
|  | Fisher          | 20039, 20047, 20000, 20104, 20046                             |
|  | Flint           | 20209, 20348  |
|  | Fuji            | 20035, 20033  |
|  | Fujitsu         | 20037, 20045, 20000   |
|  | Fujitsu General | 20037   |
|  | Funai           | 20037, 20000, 20278, 21593                                    |

|  |                 |  |
|--|-----------------|--|
|  | Galaxi          | 20000  |
|  | Galaxis         | 20278  |
|  | Garrard         | 20000  |
|  | Gateway         | 21972  |
|  | GE              | 20060, 20035, 20048, 20240, 20000, 20226, 20320, 20807, 21035, 21060               |
|  | GEC             | 20081  |
|  | Gemini          | 20060  |
|  | General         | 20045  |
|  | General Technic | 20348  |
|  | Genexxa         | 20037, 20000, 20104, 20278   |
|  | Go Video        | 20240, 20432, 20614, 21137   |
|  | GoldStar        | 20035, 20037, 20039, 20000, 20209, 20278, 20038, 20225, 20226, 20480, 21137, 21237 |
|  | Goodmans        | 20037, 20081, 20240, 20000, 20209, 20278, 20348, 20352, 20637, 20642, 20742        |

|  |           |  |
|--|-----------|--|
|  | GPX       | 20037  |
|  | Gradiente | 20000  |
|  | Graetz    | 20240, 20104, 20041  |
|  | Granada   | 20035, 20037, 20048, 20081, 20240, 20000, 20042, 20104, 20046, 20226 |
|  | Grandin   | 20037, 20000, 20209, 20278, 20742                                    |
|  | Grundig   | 20081, 20226, 20320, 20347, 20348, 20352, 20742                      |

**H**

|  |                  |  |
|--|------------------|--|
|  | Haaz             | 20348  |
|  | Hanimex          | 20352  |
|  | Hanseatic        | 20037, 20081, 20209, 20038   |
|  | Haojie           | 20240  |
|  | Harley Davidson  | 20000  |
|  | Harman/Kardon    | 20081, 20038   |
|  | Headquarter      | 20046  |
|  | Hewlett Packard  | 21972  |
|  | Hi-Q             | 20035, 20047, 20000  |
|  | Hinari           | 20240, 20209, 20041, 20278, 20352                                    |
|  | Hisawa           | 20209, 2035  |
|  | Hischito         | 20045  |
|  | Hitachi          | 20035, 20037, 20081, 20240, 20045, 20000, 20042, 20041, 20046, 20089 |
|  | Hoehner          | 20278, 20642   |
|  | Hornophon        | 20081  |
|  | Howard Computers | 21972  |
|  | HP               | 21972  |

|  |                        |  |
|--|------------------------|--|
|  | Hughes Network Systems | 20042, 20739                             |
|  | Humax                  | 20739                                    |
|  | Hush                   | 21972                                    |
|  | Hypson                 | 20037, 20000, 20209, 20278, 20352, 20480 |
|  | Hytek                  | 20047, 20000                             |

**I**

|  |               |                                   |
|--|---------------|-----------------------------------|
|  | iBUYPOWER     | 21972                             |
|  | Imperial      | 20000                             |
|  | Ingersol      | 20240, 20209                      |
|  | Interbuy      | 20037                             |
|  | Interfunk     | 20081, 20104                      |
|  | Internal      | 20278, 20637                      |
|  | International | 20037, 20278, 20642               |
|  | Intervision   | 20037, 20000, 20209, 20278, 20348 |
|  | Irradio       | 20037, 20081, 21137               |
|  | ITT           | 20240, 20104, 20041, 20046, 20106 |
|  | ITT Nokia     | 20240, 20104, 20041, 20106        |
|  | ITV           | 20037, 20278                      |

**J**

|  |        |  |
|--|--------|--|
|  | Janeil | 20240                                    |
|  | JBL    | 20278                                    |
|  | Jensen | 20067, 20041                             |
|  | JMB    | 20209, 20348, 20352, 20742               |
|  | Joyce  | 20000                                    |
|  | JVC    | 20184, 20081, 20045, 20067, 20041, 21162 |

**K**

|  |                 |   |
|--|-----------------|---|
|  | Kambrook        | 20037   |
|  | Karcher         | 20081, 20278, 20642                             |
|  | KEC             | 20037, 20278                                    |
|  | Kendo           | 20037, 20209, 20278, 20106, 20315, 20348, 20642 |
|  | Kenwood         | 20067, 20041, 20038, 20046                      |
|  | KIC             | 20000   |
|  | Kimari          | 20047   |
|  | Kneissel        | 20037, 20209, 20278, 20348, 20352               |
|  | Kodak           | 20035, 20037                                    |
|  | Kolin           | 20043, 20041                                    |
|  | Kolster         | 20209   |
|  | KTV             | 20000   |
|  | Kuba            | 20047   |
|  | Kuba Electronic | 20047   |

**L**

|  |          |  |
|--|----------|--|
|  | Lenco    | 20278  |
|  | LI-Q     | 20037, 20240, 20045, 20000, 20042, 20209, 20278, 20038, 20225, 20480, 21137, 21237 |
|  | Lifetec  | 20209, 20348   |
|  | Linksys  | 21972  |
|  | Lloyd's  | 20240, 20000, 20038  |
|  | Loewe    | 21062, 20162, 20037, 20081, 21262, 21562   |
|  | Logik    | 20240, 20000, 20209, 20106   |
|  | Lumatron | 20278, 21137   |
|  | Lunatron | 21137  |

|                 |   |
|-----------------|---|
| Luxor           | 20048, 20047, 20104, 20043, 20046, 20106, 20315   |
| LXI             | 20037, 20000, 20042, 20067  |
| M Electronic    | 20037, 20240, 20000, 20038  |
| Magnadyne       | 20081   |
| Magnasonic      | 20037, 20240, 20000, 20278, 21278   |
| Magnavox        | 20035, 20037, 20048, 20039, 20081, 20240, 20000, 20226, 20618, 20642, 21593, 21781                                    |
| Magnin          | 20240   |
| Magnum          | 20642   |
| Manesth         | 20081, 20045, 20209   |
| Marantz         | 20035, 20081, 20209, 20038  |
| Mark            | 20000, 20278  |
| Marta           | 20037   |
| Mastec          | 20642   |
| Master's        | 20278   |
| Matsui          | 20037, 20240, 20209, 20278, 20348, 20352, 20742   |
| Matsushita      | 20035, 20162, 20081, 20226, 21162   |
| Media Center PC | 21972   |
| Mediator        | 20081   |
| Medion          | 20209, 20348, 20352, 20642  |
| MEI             | 20035   |
| Memorex         | 20035, 20162, 20037, 20048, 20039, 20047, 20240, 20000, 20104, 20209, 20278, 20046, 20348, 20479, 21162, 21237, 21262 |
| Metronic        | 20081   |
| Metz            | 21062, 20162, 20037, 20081, 20226, 20347, 20836, 21162, 21262, 21562  |
| MGA             | 20060, 20240, 20043   |
| MGN Technology  | 20240   |
| Micormay        | 20348   |
| Micromaxx       | 20209   |
| Microsoft       | 21972   |
| Midland         | 20240   |
| Migros          | 20000   |
| Mind            | 21972   |
| Minolta         | 20042   |
| Mitsubishi      | 20060, 20048, 20047, 20081, 20000, 20042, 20067, 20043, 20041, 20480, 20642, 20807                                    |
| Motorola        | 20035, 20048  |
| MTC             | 20240, 20000  |
| MTX             | 20000   |
| Multitec        | 20037   |
| Multitech       | 20039, 20000  |
| Murphy          | 20000   |
| Myryad          | 20081   |
| NAD             | 20240, 20104  |
| Naiko           | 20348, 20642  |
| NAP             | 20039   |
| National        | 20226   |

|                    |   |
|--------------------|---|
| Nebula Electronics | 20033   |
| NEC                | 20035, 20037, 20048, 20104, 20067, 20041, 20278, 20038, 21137                             |
| Neckermann         | 20081, 20041  |
| Nesco              | 20000   |
| Neufunk            | 20209   |
| Newave             | 20037   |
| Nikkai             | 20278   |
| Nikko              | 20037, 20278  |
| Nikkodo            | 20037, 20278  |
| Nishi              | 20240   |
| Niveus Media       | 21972   |
| Noblex             | 20240   |
| Nokia              | 20048, 20081, 20240, 20042, 20104, 20041, 20278, 20046, 20106, 20315                      |
| Nordmende          | 20067, 20041, 20320   |
| Northgate          | 21972   |
| Nu-Tec             | 20209   |
| Oceanic            | 20048, 20081, 20000, 20104, 20041, 20046, 20106   |
| Okano              | 20209, 20278, 20315, 20348  |
| Olympus            | 20035, 20162, 20104, 20226  |
| Onimax             | 20642   |
| Onkyo              | 20222   |
| Optimus            | 21062, 20035, 20162, 20037, 20048, 20047, 20240, 20000, 20104, 20432, 21162, 21262        |
| Orion              | 20184, 20240, 20000, 20104, 20121, 20209, 20002, 20278, 20348, 20352, 20479, 20742, 21479 |
| Orson              | 20000   |
| Osaki              | 20037, 20000  |
| Otake              | 20209   |
| Otto Versand       | 20081   |
| Pace               | 20352   |
| Pacific            | 20000, 20348, 20642, 20742  |
| Packard Bell       | 21972   |
| Palladium          | 20037, 20209, 20041, 20348  |
| Palsonic           | 20000, 20642  |
| Panama             | 20035   |
| Panasonic          | 21062, 20035, 20162, 20000, 20225, 20226, 20614, 20616, 20836, 21035, 21162, 21262, 21562 |
| Pathe Cinema       | 20043   |
| Pathe Marconi      | 20041   |
| Penney             | 20035, 20162, 20037, 20047, 20081, 20240, 20000, 20042, 20067, 20038, 21035, 21237        |
| Pentax             | 20042   |
| Perdio             | 20000, 20209  |
| Philco             | 20035, 20081, 20000, 20209, 20038, 20226, 20479   |

## O

## P

|             |  |
|-------------|--|
| Philips     | 20035, 20162, 20048, 20081, 20045, 20000, 20209, 20226, 20616, 20618, 20739, 21081, 21181        |
| Phoenix     | 20278  |
| Phonola     | 20081  |
| Pilot       | 20037  |
| Pioneer     | 20162, 20081, 20042, 20067   |
| Polk Audio  | 20081  |
| Portland    | 20278, 20637   |
| Presidian   | 21593  |
| Prinz       | 20000  |
| Profitronic | 20081, 20240   |
| Proline     | 20000, 20278, 20320, 20642   |
| Proscan     | 20060, 21060   |
| Proscoc     | 20278  |
| Prosonic    | 20209, 20278   |
| Protec      | 20000  |
| Protech     | 20081  |
| ProVision   | 20278  |
| Pulsar      | 20039, 20240, 20278  |
| Pulser      | 20240  |
| Pye         | 20081, 20000   |
| Qisheng     | 20060  |
| Quarter     | 20046  |
| Quartz      | 20035, 20047, 20046  |
| Quasar      | 20035, 20162, 20002, 20278, 20226, 21035, 21162  |
| Quelle      | 20081  |
| Radialva    | 20037, 20048, 20081  |
| Radiola     | 20081  |
| Radionette  | 20037, 21137   |
| RadioShack  | 20035, 20162, 20037, 20048, 20047, 20240, 20000, 20104, 20046, 21162                             |
| Radix       | 20037  |
| Randex      | 20037  |
| Rank        | 20041  |
| Rank Arena  | 20041  |
| RCA         | 20060, 20035, 20048, 20240, 20045, 20000, 20042, 20106, 20226, 20320, 20807, 20880, 21035, 21060 |
| Realistic   | 20035, 20162, 20037, 20048, 20047, 20240, 20000, 20104, 20121, 20278, 20046, 21162               |
| Reoc        | 20348  |
| ReplayTV    | 20614, 20616   |
| Rex         | 20041  |
| Ricavision  | 21972  |
| Rio         | 21137  |
| Roadstar    | 20037, 20081, 20240, 20278, 20038, 20742   |
| Runco       | 20039  |
| Saba        | 20041, 20278, 20320  |
| Saisho      | 20209, 20348   |
| Salora      | 20104, 20043, 20046, 20106   |

## S

|               |  |
|---------------|--|
| Sampo         | 20037, 20048   |
| Samsung       | 20060, 20240, 20045, 20000, 20038, 20432, 20739, 21014   |
| Samtron       | 20240  |
| Sanky         | 20048, 20039   |
| Sansei        | 20048  |
| Sansui        | 20240, 20000, 20067, 20209, 20041, 20002, 20106, 20348, 20479, 21479   |
| Sanyo         | 20048, 20047, 20240, 20000, 20104, 20067, 20209, 20046, 20348, 20479, 21137  |
| Saville       | 20240, 20278, 20352  |
| SBR           | 20081  |
| ScanSonic     | 20240  |
| Schaub Lorenz | 20000, 20104, 20041, 20106, 20315, 20348   |
| Schneider     | 20037, 20081, 20240, 20000, 20042, 20278, 20348, 20352, 20642, 21137   |
| Scott         | 20184, 20045, 20121, 20043   |
| Sears         | 20060, 20035, 20162, 20037, 20048, 20039, 20047, 20033, 20045, 20000, 20042, 20104, 20067, 20043, 20209, 20041, 21237, 20046 |
| Seaway        | 20278  |
| SEG           | 20081, 20240, 20278, 20637, 20642  |
| SEI           | 20081  |
| Sei-Sinudyne  | 20081  |
| Seleco        | 20037, 20041   |
| Semp          | 20045  |
| Sentra        | 20278  |
| Sharp         | 20037, 20048, 20047, 20032, 20000, 20209, 20807  |
| Shinco        | 20000  |
| Shintom       | 20039, 20240, 20000, 20104   |
| Shivaki       | 20037  |
| Shogun        | 20240  |
| Siemens       | 20037, 20081, 20104, 20046, 20320, 20347   |
| Siera         | 20081  |
| Signature     | 20060, 20035, 20037, 20048, 20000, 20046, 20479  |
| Silva         | 20037  |
| Silver        | 20278  |
| SilverCrest   | 20642  |
| Singer        | 20037, 20240, 20045, 20348   |
| Sinudyne      | 20081, 20209, 20352  |
| Smaragd       | 20348  |
| Sonic Blue    | 20614, 20616, 21137  |
| Sonographe    | 20046  |
| Sonolor       | 20048, 20046   |
| Sontec        | 20037, 20278   |
| Sonwa         | 20642  |
| Sony          | 20035, 20048, 20047, 20032, 20033, 20000, 20067, 20046, 20106, 20226, 20636, 21232, 21972                                    |

## T

|               |  |
|---------------|--|
| Soundmaster   | 20000  |
| Soundwave     | 20037, 20209, 20348  |
| Stack 9       | 21972  |
| Standard      | 20278  |
| Stern         | 20278  |
| STS           | 20042  |
| Sunkai        | 20209, 20278, 20348  |
| Sunstar       | 20000  |
| Suntronic     | 20000  |
| Supra         | 20037, 20278, 20348  |
| Susumu        | 20037  |
| SV2000        | 20000  |
| SVA           | 20000  |
| Sylvania      | 20035, 20081, 20000, 20043, 21593, 21781                             |
| Symphonic     | 20240, 20000, 20002, 21593   |
| Systemax      | 21972  |
| T+A           | 20162  |
| Tagar Systems | 21972  |
| Taisho        | 20209  |
| Tandberg      | 20278  |
| Tandy         | 20000, 20104   |
| Tashiko       | 20037, 20048, 20081, 20240, 20000                                    |
| Tatung        | 20048, 20081, 20045, 20000, 20067, 20043, 20209, 20041, 20348, 20352 |
| Tchibo        | 20348  |
| TCM           | 20348  |
| Teac          | 20037, 20000, 20067, 20041, 20278, 20637, 20642, 21593               |
| Technics      | 20035, 20162, 20037, 20081, 20000, 20226, 21162                      |
| TechniSat     | 20348  |
| Technosonic   | 20352  |
| Teco          | 20035, 20037, 20048, 20041, 20038                                    |
| Tedex         | 20037, 20209, 20348, 20642   |
| Teknika       | 20035, 20037, 20000  |
| Teleavia      | 20041  |
| Telecorder    | 20240  |
| Telefunken    | 20209, 20041, 20278, 20320, 20642                                    |
| Telerent      | 20226  |
| Telestarc     | 20037  |
| Teletech      | 20000, 20278   |
| Tensai        | 20037, 20000, 20278  |
| Tevion        | 20209, 20348, 20479, 20642   |
| Textet        | 20278  |
| Thomas        | 20000, 20002   |
| Thomson       | 20060, 20067, 20041, 20278, 20320                                    |
| Thorn         | 20037, 20104, 20041, 20320   |
| Tisonic       | 20278  |
| Tivo          | 20618, 20636, 20739, 21996   |
| TMK           | 20240, 20000   |

|                    |   |
|--------------------|---|
| TNIX               | 20037   |
| Tocom              | 20240   |
| Tokai              | 20037, 20104, 20041   |
| Topline            | 20348   |
| Toshiba            | 20081, 20240, 20045, 20000, 20042, 20067, 20043, 20209, 20041, 20352, 20432, 20742, 20845, 21008, 21145, 21972, 21996 |
| Tosonic            | 20278   |
| Totevision         | 20037, 20240  |
| Touch              | 21972   |
| Toyoda             | 20278   |
| Tradex             | 20081   |
| Triad              | 20278   |
| Trix               | 20037   |
| <b>U</b> Uher      | 20240   |
| Ultra              | 20045, 20278  |
| Ultravox           | 20278   |
| Unitech            | 20240   |
| United             | 20348, 20742, 21593   |
| Universum          | 20037, 20081, 20240, 20000, 20104, 20209, 20106, 20348, 21137   |
| <b>V</b> Vector    | 20045   |
| Vector Research    | 20184, 20038  |
| Victor             | 20067, 20041  |
| Video Concepts     | 20045   |
| Video Technic      | 20000   |
| Videomagic         | 20037   |
| Videosonic         | 20240, 20000  |
| Viewsonic          | 21972   |
| Villain            | 20000   |
| Voodoo             | 21972   |
| Wards              | 20060, 20035, 20037, 20048, 20039, 20047, 20081, 20033, 20240, 20045, 20000, 20042, 20043, 20041, 20038, 20046, 20479 |
| Watson             | 20081, 20352, 20642   |
| Weltblick          | 20037   |
| Wharfedale         | 20642   |
| White Westinghouse | 20000, 20209, 20278, 20479, 20637   |
| World              | 20209, 20002, 20348, 20479  |
| <b>X</b> XR-1000   | 20035, 20240, 20000   |
| <b>Y</b> Yamaha    | 20041, 20038  |
| Yamishi            | 20278   |
| Yoko               | 20037, 20240  |
| Zenith             | 20037, 20039, 20033, 20000, 20209, 20041, 20278, 20479, 20637, 21137, 21479   |
| ZT Group           | 21972   |
| ZX                 | 20209, 20348, 20352   |

| <b>PVR</b> ※3            |                     |
|--------------------------|---------------------|
| <b>A</b> ABS             | 21972               |
| Alienware                | 21972               |
| <b>C</b> CyberPower      | 21972               |
| <b>D</b> Dell            | 21972               |
| DirectTV                 | 20739               |
| <b>G</b> Gateway         | 21972               |
| Go Video                 | 20614               |
| <b>H</b> Hewlett Packard | 21972               |
| Howard Computers         | 21972               |
| HP                       | 21972               |
| Hughes Network Systems   | 20739               |
| Humax                    | 20739               |
| Hush                     | 21972               |
| <b>I</b> iBUYPOWER       | 21972               |
| <b>L</b> Linksys         | 21972               |
| <b>M</b> Media Center PC | 21972               |
| Microsoft                | 21972               |
| Mind                     | 21972               |
| <b>N</b> Niveus Media    | 21972               |
| Northgate                | 21972               |
| <b>P</b> Panasonic       | 20614, 20616        |
| Philips                  | 20618, 20739        |
| <b>R</b> RCA             | 20880               |
| ReplayTV                 | 20614, 20616        |
| <b>S</b> Samsung         | 20739               |
| Sonic Blue               | 20614, 20616        |
| Sony                     | 20636, 21972        |
| Stack 9                  | 21972               |
| Systemax                 | 21972               |
| <b>T</b> Tagar Systems   | 21972               |
| Tivo                     | 20618, 20636, 20739 |
| Toshiba                  | 21008, 21972, 21996 |
| Touch                    | 21972               |
| <b>V</b> Viewsonic       | 21972               |
| Voodoo                   | 21972               |
| <b>Z</b> ZT Group        | 21972               |

| <b>DVD Player</b>  |  |
|--------------------|--|
| <b>1</b> 3D LAB    | 30503, 30539                             |
| 4Kus               | 31158                                    |
| <b>A</b> A-Trend   | 30714                                    |
| Acoustic Solutions | 30713, 30730, 31228                      |
| AEG                | 30770, 30788, 30790, 31923               |
| AFK                | 31051, 31152, 31923                      |
| Aim                | 30672, 30699, 30833                      |
| Airis              | 30672, 31005, 31224, 31250, 31321, 31345 |
| Aiwa               | 30533, 30641                             |

|                         |   |
|-------------------------|---|
| Akai                    | 30690, 30695, 30705, 30770, 30788, 30790, 30884, 30898, 30899, 31115, 31205, 31233, 31695 |
| Akashi                  | 30838   |
| AKI                     | 31005   |
| Akira                   | 30699, 31321  |
| Akura                   | 30898, 31051, 31140, 31233, 31367   |
| Alba                    | 30672, 30539, 30717, 30695, 30699, 30713, 30730, 30783, 30884, 31140, 31530, 31695        |
| Alco                    | 30790   |
| Alize                   | 31151   |
| All-Tel                 | 31451   |
| Allegro                 | 30869   |
| Altacom                 | 31224   |
| Amitech                 | 30784, 30770, 30850   |
| Amoi                    | 30852   |
| Amphion Media Works     | 30872   |
| Amstrad                 | 30713, 30770, 31151, 31367  |
| AMW                     | 30872   |
| Anam                    | 31913   |
| Ansonic                 | 30759, 30774, 30831   |
| Apex Digital            | 30533, 30672, 30717, 30755, 30794, 30796, 30797, 30830, 31004, 31020, 31056, 31061        |
| Aristona                | 30539, 30646  |
| Arrgo                   | 31023   |
| ASCOMTEC                | 31923   |
| Asono                   | 31224   |
| Aspire Digital          | 31168   |
| Atacom                  | 31224   |
| Audiosonic              | 30690, 31923  |
| Audiovox                | 30717, 30790  |
| Audioworld              | 30790   |
| Autovox                 | 30713   |
| Auvio                   | 30843   |
| Awa                     | 30730, 30872  |
| Axion                   | 30730   |
| <b>B</b> Base           | 31451   |
| Basic Line              | 30713   |
| Baze                    | 30898   |
| BBK                     | 30862, 31224  |
| Beep                    | 31163   |
| Bellagio                | 31004   |
| Belson                  | 31086, 31923  |
| Binatone                | 31923   |
| Black Diamond           | 30713, 30833, 30884   |
| Blaupunkt               | 30717   |
| Blusens                 | 31233, 31321  |
| Blue Nova International | 31321   |
| Blue Parade             | 30571   |

|                       |   |
|-----------------------|---|
| Blue Sky              | 30672, 30651, 30695, 30699, 30713, 30790, 30843, 31423  |
| Boghe                 | 31004   |
| Boman                 | 30783, 30898, 31005   |
| Bose                  | 32023   |
| Brainwave             | 30770, 31115  |
| Brandt                | 30503, 30651, 30551   |
| Broksonic             | 30695   |
| Bush                  | 30672, 30717, 30690, 30699, 30713, 30723, 30730, 30831, 30833, 30884, 31051, 31140, 31483, 31695, 31832 |
| Byd:sign              | 30872   |
| <b>C</b> C-Tech       | 30798, 31152  |
| California Audio Labs | 30490   |
| Cambridge Audio       | 30751, 31109  |
| Cambridge Soundworks  | 30690   |
| Campomatic Digital    | 31051   |
| Cat                   | 30699, 30789, 31421, 31923  |
| CCE                   | 30730   |
| Celestial             | 31020   |
| cello                 | 31730   |
| Centrex               | 30672, 31004  |
| Centrum               | 30713, 30789, 31005, 31227, 31923   |
| CGV                   | 30751, 31115  |
| Changhong             | 30627, 31061  |
| Cinea                 | 30831, 30841  |
| Cinetec               | 30713, 30872  |
| cineULTRA             | 30699   |
| CineVision            | 30833, 30869, 31483   |
| Citizen               | 30695   |
| Clairtone             | 30571   |
| Classic               | 30730, 31730  |
| Clatronic             | 30672, 30675, 30788, 31233  |
| Clayton               | 30713   |
| Coby                  | 30730, 30852, 31086, 31321, 31923   |
| Codex                 | 31233   |
| Commax                | 31321   |
| Conia                 | 30672, 30852, 31321   |
| Contel                | 30788   |
| Continental Edison    | 30831, 30872  |
| Craig                 | 30831   |
| Creative              | 30503, 30539  |
| Crown                 | 30690, 30713, 30770, 31115  |
| Crypto                | 31228   |
| Curtis Mathes         | 31087   |
| Cybercom              | 30831   |
| CyberHome             | 30714, 30816, 30874, 31023, 31024, 31117, 31129, 31502  |
| Cytron                | 30651, 30705, 30774, 31347  |
| <b>D</b> D-Vision     | 31115, 31367  |
| Daenyx                | 30872   |

|                |   |
|----------------|---|
| Daewoo         | 30490, 30784, 30705, 30714, 30770, 30833, 30869, 30872, 31172, 31483, 31906 |
| Dalton         | 31036   |
| Dansai         | 30770, 30783, 31115, 31695  |
| Dantax         | 30539, 30713, 30723, 30790  |
| Daytek         | 30872, 31005  |
| Dayton         | 30872   |
| DCE            | 30831   |
| Decca          | 30770, 31115  |
| Denon          | 30490, 30634, 31634, [32134]*   |
| Denver         | 30672, 30699, 30788, 30898, 31056, 31104, 31321, 31923                      |
| Denzel         | 30665   |
| Desay          | 30843, 31212  |
| Dgtec          | 30672   |
| Diamond        | 30651, 30751, 30768, 30790  |
| Digihome       | 30713   |
| DigiLogic      | 30713   |
| digiRED        | 30717   |
| Digitech       | 31832   |
| Digitor        | 30651, 30690, 30833, 31005, 31423   |
| Digitrex       | 30672, 31004, 31056   |
| DiK            | 30831   |
| Dinamic        | 30788   |
| Disney         | 30675, 30831, 31270   |
| DiViDo         | 30705   |
| DK Digital     | 30831   |
| DMTech         | 30783, 31271  |
| Dragon         | 30831   |
| DreamX         | 31151   |
| DSE            | 30833, 31152, 31730   |
| Dual           | 30651, 30665, 30675, 30713, 30730, 30783, 30790, 30831, 31023               |
| Durabrand      | 30713, 30831, 31023, 31502  |
| DVD2000        | 30521   |
| DVX            | 30768   |
| <b>E</b> E:max | 31233, 31321  |
| EagleTec       | 30714   |
| eBench         | 31152   |
| ECC            | 30730   |
| Eclipse        | 30723, 30751  |
| Elfunk         | 30713, 30850, 30884   |
| Elin           | 30770   |
| Elite          | 31152   |
| Ellion         | 30850, 31421  |
| Elta           | 30672, 30690, 30770, 30788, 30850, 31051, 31115, 31151, 31233               |
| Eltax          | 31233, 31321  |
| Emerson        | 30591, 30675, 30705, 30821, 31268   |
| Enterprise     | 30591   |



|                  |  |
|------------------|--|
| Entivo           | 30503, 30539   |
| Enzer            | 30784, 30770, 31228  |
| ESA              | 30821, 31268   |
| EuroLine         | 30675, 30788, 31115, 31233   |
| <b>F</b> Fenner  | 30651  |
| Ferguson         | 30651, 30695, 30713, 30884, 30898, 31695, 31730  |
| Finlux           | 30672, 30591, 30741, 30751, 30770, 30783   |
| Firstline        | 30651, 30713, 30843, 30869, 31530  |
| Fisher           | 30670  |
| Funai            | 30675, 30695, 31268  |
| Fusion           | 30862  |
| <b>G</b> Gateway | 31158  |
| GE               | 30522, 30815, 30717  |
| General Electric | 30717  |
| Germatic         | 31051  |
| Global Link      | 31224  |
| Global Solutions | 30768  |
| Global Sphere    | 31152  |
| Go Video         | 30573, 30744, 30717, 30715, 30741, 30783, 30833, 30869, 31044, 31075, 31099, 31158, 31483, 31730               |
| GoldStar         | 30591, 30741, 30869  |
| Goodmans         | 30651, 30690, 30713, 30723, 30730, 30783, 30790, 30833, 31004, 31140, 31423, 31530, 31730, 31923               |
| GP Audio         | 31140  |
| GPX              | 30699, 30741   |
| Gradiente        | 30490, 30651   |
| Graetz           | 30665  |
| Gran Prix        | 30831, 30898   |
| Grandin          | 30713, 31233   |
| Greenhill        | 30717  |
| Grundig          | 30539, 30651, 30551, 30670, 30686, 30695, 30705, 30713, 30775, 30790, 31004, 31036, 31695, 31730, 31832, 31920 |
| Grunkel          | 30770, 30790, 30831  |
| <b>H</b> H & B   | 30713, 30841, 30850, 31233, 31421  |
| Haaz             | 30751, 31152   |
| Haier            | 30843  |
| Hanseatic        | 30741, 30783, 30790  |
| Harman/Kardon    | 30582, 30702   |
| HCM              | 30788  |
| HDT              | 30705  |
| HE               | 30730, 31163, 31923  |
| Henss            | 30713  |
| HiMAX            | 30843  |
| Hitachi          | 30573, 30664, 30665, 30713, 31247, 31920   |
| Hiteker          | 30672, 31923   |
| Hoeher           | 30651, 30713, 30831, 31004, 31224  |

|                              |  |
|------------------------------|--|
| Home Electronics             | 30730, 30770   |
| Home Tech Industries         | 31224  |
| Hoyo                         | 30665  |
| Humax                        | 30646  |
| Hyundai                      | 30783, 30850, 31061, 31228                             |
| <b>I</b> iLo                 | 31348  |
| Ingelen                      | 30788  |
| Ingersol                     | 31023  |
| Initial                      | 30839, 30717   |
| Inno Hit                     | 30713  |
| Insignia                     | 31268  |
| Integra                      | 30571, 30627, 31634                                    |
| Irradio                      | 30869, 31115, 31224, 31233                             |
| IRT                          | 30783  |
| ISP                          | 30695  |
| <b>J</b> Jamo                | 31036  |
| Jaton                        | 30665  |
| JBL                          | 30702  |
| JDB                          | 30730  |
| JDV                          | 31367  |
| Jeken                        | 30699  |
| Jepssen                      | 31250  |
| JMB                          | 30695  |
| JNC                          | 30672, 31271   |
| JSI                          | 31423  |
| JVC                          | 30503, 30539, 30558, 30623, 30867, 31164, 31597, 31860 |
| jWin                         | 31051  |
| <b>K</b> Kansas Technologies | 31233, 31530   |
| Karcher                      | 30783  |
| Kawasaki                     | 30790  |
| Kendo                        | 30672, 30699, 30713, 30831                             |
| Kennex                       | 30713, 30770, 30898                                    |
| Kenwood                      | 30490, 30534   |
| Kiiri                        | 30770  |
| Kiss                         | 30665, 30841, 31523                                    |
| KLH                          | 30815, 30717, 30790, 31020                             |
| Kloss                        | 30533  |
| Koda                         | 31230  |
| Konka                        | 31192  |
| Koss                         | 30651, 31061, 31423                                    |
| Kreisen                      | 31421  |
| KXD                          | 31321, 31923   |
| <b>L</b> Lasonic             | 30627, 30798, 30789                                    |
| Lawson                       | 30768  |
| Lecson                       | 31533  |
| Leiker                       | 30872  |
| Lenco                        | 30651, 30699, 30713, 30770, 30774                      |
| Lenoir                       | 31228  |
| Lenoxx                       | 30690, 30838   |
| Lexia                        | 30699, 30768   |

|                     |  |
|---------------------|--|
| LG                  | 30591, 30741, 30790, 30869, 31906                                    |
| Lifetec             | 30651, 30831, 31347  |
| Limit               | 30768, 31104   |
| LiteOn              | 31058, 31158   |
| Lodos               | 30713  |
| Loewe               | 30539, 30511, 30741, 30885   |
| Logik               | 30713, 30884   |
| Logix               | 30705, 30783   |
| Luker               | 31367  |
| Lumatron            | 30695, 30705, 30713, 30741, 30833, 31115, 31321, 31832               |
| Lunatron            | 30741  |
| Luxman              | 30573  |
| Luxor               | 30713, 31004, 31695, 31730   |
| <b>M</b> Magnasonic | 30651, 30675   |
| Magnat              | 31923  |
| Magnavox            | 30503, 30539, 30646, 30675, 30713, 30821, 30885, 31140, 31268        |
| Magnex              | 30723  |
| Majestic            | 31345  |
| Manhattan           | 30705, 30713   |
| Marantz             | 30503, 30539, 30675  |
| Mark                | 30713  |
| Marquant            | 30770  |
| Matsui              | 30672, 30651, 30695, 30713, 30884, 31004, 31695, 31730               |
| Maxdorf             | 30788  |
| Maxent              | 31347  |
| Maxim               | 30713, 30872, 31367  |
| Maya                | 31345  |
| MBO                 | 30690, 30730, 31730  |
| McIntosh            | 31533  |
| MDS                 | 30713  |
| Mecotek             | 30770  |
| Medion              | 30651, 30630, 30774, 30783, 30831, 31006, 31270, 31345, 31347, 31423 |
| MEI                 | 30790  |
| Memorex             | 30690, 30695, 30831, 31270   |
| Metronic            | 30690  |
| Metz                | 30525, 30571, 30713  |
| MiCO                | 30723, 30751, 31223  |
| Micromaxx           | 31695  |
| Micromedia          | 30503, 30539   |
| Micromega           | 30539, 31005   |
| Microsoft           | 30522, 31708   |
| Microstar           | 30831  |
| Minato              | 30752  |
| Minax               | 30713  |
| Minerva             | 30705  |
| Minoka              | 30770, 31115   |
| Mintek              | 30839, 30717   |
| Mirror              | 30752  |

|                |  |
|----------------|--|
| Mitsubishi     | 31521, 30521, 30713, 31403   |
| Mizuda         | 30770, 31451   |
| Monyka         | 30665  |
| MPX            | 30843  |
| Mustek         | 30730, 31730   |
| Mx Onda        | 30651, 30751, 31223  |
| Mystral        | 30831  |
| <b>N</b> NAD   | 30741  |
| Naiko          | 30770, 31004, 31367  |
| Narita         | 31367  |
| NEC            | 30741, 30869, 31404  |
| Neovia         | 31271  |
| Nesa           | 30717  |
| Neufunk        | 30665  |
| Nevir          | 30770, 30831, 31197  |
| NexxTech       | 31402  |
| Nikkai         | 31923  |
| Nintaus        | 31051, 31202   |
| Niro           | 32024  |
| Norcent        | 30872, 31923   |
| Nordmende      | 30774, 30831   |
| Noriko         | 30752  |
| Nova           | 31923  |
| Nowa           | 30843  |
| Nu-Tec         | 31228  |
| <b>O</b> Okano | 30752  |
| Olidata        | 30672  |
| Omni           | 30690, 30833, 30838, 30862, 31104, 31832   |
| Onix           | 30838  |
| Onkyo          | 30503, 30627   |
| Oopla          | 31158  |
| Oppo           | 31224  |
| Optim          | 30843  |
| Optimus        | 30525, 30571   |
| Orbit          | 30872  |
| Orion          | 30695, 31233, 31695  |
| Oritron        | 30651  |
| Ormond         | 30713  |
| <b>P</b> P&B   | 31451  |
| Pacific        | 30695, 30713, 30759, 30768, 30790, 30831   |
| Packard Bell   | 30831  |
| Palladium      | 30695, 30713, 31906, 31920   |
| Palsonic       | 30672, 30852, 31056, 31321   |
| Panasonic      | 30503, 30490, 30571, 30703, 31362, 31462, 31490, 31579, 31762, 31834, 31905, 31908 |
| Panda          | 30717, 30789, 31203  |
| peekTon        | 30898, 31224   |
| Philco         | 30690, 30862   |
| Philips        | 30503, 30539, 30646, 30675, 30854, 30885, 31158, 31260, 31267, 31340, 31354        |

|                     |  |
|---------------------|--|
| Philo               | 31345  |
| Phonotrend          | 30699  |
| PianoDisc           | 31024  |
| Pioneer             | 30490, 30525, 30571, 30631, 31965                                    |
| Plu2                | 30850  |
| Pointer             | 30784  |
| Polaroid            | 31020, 31061, 31086  |
| Polk Audio          | 30539  |
| Portland            | 30770  |
| Powerpoint          | 30872, 31005   |
| Presidian           | 30675  |
| Prima               | 31228  |
| Prinz               | 30831  |
| Prism               | 30705, 30831   |
| Pro2                | 31345  |
| ProCaster           | 31004  |
| Proceed             | 30672  |
| Proline             | 30672, 30651, 30686, 30833, 31004, 31483                             |
| Proscan             | 30522  |
| Proson              | 30713  |
| Prosonic            | 30699, 30752   |
| ProVision           | 30699, 30730, 31163, 31321, 31923                                    |
| Pye                 | 30539, 30646   |
| <b>Q</b> QONIX      | 31051  |
| Qwestar             | 30651  |
| <b>R</b> Radionette | 30741, 30869, 31906, 32024   |
| RadioShack          | 30571  |
| Raite               | 30665  |
| RCA                 | 30522, 30571, 30717, 30790, 30822, 31022, 31132, 31769, 31913, 31965 |
| Realistic           | 30571  |
| REC                 | 30490  |
| Redstar             | 30759, 30763, 30770, 30788, 30898, 31345, 31923                      |
| Relisys             | 31347  |
| Reoc                | 30752, 30768   |
| Revoy               | 30699, 30841   |
| Rex                 | 30838  |
| Richmond            | 31233  |
| Rio                 | 30869  |
| Roadstar            | 30672, 30690, 30699, 30713, 30730, 30833, 30898, 31051, 31227        |
| Rocksonic           | 30789  |
| Ronin               | 30872  |
| Rotel               | 30558, 30623   |
| Rowa                | 30717, 30759, 30872, 31004   |
| Rownsonic           | 30789  |
| <b>S</b> Saba       | 30651, 3055  |
| Sabaki              | 30798  |
| Saivod              | 30759, 30831, 31367  |

|                 |   |
|-----------------|---|
| Salora          | 30741   |
| Sampo           | 30752, 31321, 31347   |
| Samsung         | 30490, 30573, 30744, 30199, 30820, 30899, 31044, 31075, 31635, 31932                                    |
| Sansui          | 30784, 30695, 30751, 30763, 30768, 31051, 31228, 31230, 31695, 31832                                    |
| Sanyo           | 30670, 30675, 30695, 30713, 30873, 31228  |
| Scan            | 30705, 30850  |
| ScanMagic       | 30730, 31730  |
| ScanSonic       | 31695   |
| Schaub Lorenz   | 30770, 30788, 31115, 31151  |
| Schneider       | 30539, 30646, 30651, 30705, 30713, 30774, 30783, 30788, 30790, 30831, 30869, 31367                      |
| Schwaiger       | 30752   |
| Scientific Labs | 30768   |
| Scott           | 30672, 30651, 31005, 31036, 31233, 31423  |
| Seeltech        | 31224, 31451  |
| SEG             | 30798, 30665, 30713, 30763, 30872, 30884, 31483, 31530  |
| Sensory Science | 31158   |
| Shanghai        | 30672   |
| Sharp           | 30630, 30675, 30713, 30752, 31256, 32015, 32024   |
| Sharper Image   | 31117   |
| Sherwood        | 30717, 30741, 30770   |
| Shinco          | 30717   |
| Shinsonic       | 30533, 30839  |
| Siemssen        | 31382   |
| Sigmatek        | 31005, 31224  |
| Siltex          | 31224   |
| Silva           | 30788, 30898  |
| Silva Schneider | 30831, 30898  |
| SilverCrest     | 31152   |
| Simaudio        | 30885   |
| Singer          | 30690, 30751, 30768   |
| Sistemas        | 30672   |
| Skantic         | 30539, 30713  |
| Skymaster       | 30730, 30768  |
| Skyworth        | 30898   |
| Sliding         | 31115   |
| Slim Art        | 30784   |
| SM Electronic   | 30690, 30730, 30768, 31152  |
| Smart           | 30705, 30713  |
| Sonai           | 30755   |
| Sonashi         | 30831   |
| Sonic Blue      | 30573, 30715, 30783, 30869, 31099   |
| Sony            | 30533, 31533, 30864, 30573, 30630, 30772, 31033, 31070, 31431, 31433, 31536, 31633, 31769, 31981, 32043 |
| Sound Color     | 31233   |
| Soundmaster     | 30768   |

|                  |  |
|------------------|--|
| Soundmax         | 30768  |
| Soundwave        | 30783  |
| Spectra          | 30872  |
| Standard         | 30651, 30768, 30788, 30831, 30898  |
| Star Clusters    | 31152, 31227   |
| Starlogic        | 31005  |
| Starmedia        | 31005, 31224   |
| Stevison         | 31367  |
| Strong           | 30713  |
| Sunkai           | 30770, 30850   |
| Sunstech         | 30831  |
| Sunwood          | 30788, 30898   |
| Superscan        | 30821  |
| Supervision      | 30768, 31152   |
| SVA              | 30672, 30717, 30752, 31105   |
| Sylvania         | 30630, 30675, 30821, 31268   |
| Symphonic        | 30675, 30821, 31268  |
| Synn             | 30768  |
| Tandberg         | 30713, 31695   |
| Tangent          | 31321  |
| Targa            | 31227  |
| Tatung           | 30770, 31695   |
| Tchibo           | 30741  |
| TCL              | 31180  |
| TCM              | 30741, 30790   |
| Teac             | 30571, 30717, 30675, 30741, 30759, 30768, 30790, 30833, 31006, 31197, 31227        |
| Tec              | 30898  |
| Technica         | 31367, 31695   |
| Technics         | 30490, 30703, 31905  |
| Technika         | 30770, 30831, 31115, 31695   |
| Technisson       | 31115  |
| Technosonic      | 30730, 31051, 31115  |
| Techwood         | 30713, 31530   |
| Tedalex          | 30690, 30768, 31004, 31228   |
| Telefunken       | 30789, 30790, 30833, 31483, 31832, 31923   |
| Teletech         | 30713, 30768   |
| Tensai           | 30651, 30690, 30770  |
| Tevion           | 30651, 30798, 30768, 30833, 30898, 31036, 31227, 31347, 31382, 31483, 31730, 31923 |
| Theta Digital    | 30571  |
| Thomson          | 30522, 30511, 30551  |
| Tivo             | 31503  |
| Tokai            | 30784, 30665, 30788, 30790, 30898  |
| Tom-Tec          | 30789  |
| Top Suxess       | 31224  |
| Toshiba          | 30503, 30573, 30539, 30695, 31045, 31154, 31503, 31510, 31769                      |
| TRANS-continents | 30831, 30872, 31321, 31327   |
| Transonic        | 30730  |

|                   |  |
|-------------------|--|
| Tredex            | 30843  |
| TruVision         | 31451  |
| Tsinghua Tongfang | 31205  |
| TSM               | 31224  |
| Umax              | 30690, 31151   |
| Unimax            | 30770  |
| United            | 30675, 30695, 30699, 30713, 30730, 30788, 30884, 31115, 31152, 31228, 31367, 31832 |
| Universum         | 30591, 30713, 30741, 30790, 30869, 31227, 31530, 31913                             |
| Uptek             | 30763  |
| upXus             | 31345  |
| Urban Concepts    | 30503, 30539   |
| US Logic          | 30839  |
| Venturer          | 30790  |
| Vestel            | 30713, 30884, 31530  |
| Victor            | 31597  |
| Vieta             | 30705  |
| Viewmaster        | 30862, 31224   |
| Voxson            | 30690, 30730, 30774, 30831   |
| Vtrek             | 31228  |
| Waitec            | 31151, 31224, 31233  |
| Walkvision        | 30717  |
| Waltham           | 31530  |
| Welkin            | 30831  |
| Wellington        | 30713  |
| Weltstar          | 30713  |
| Wesder            | 30699  |
| Wharfedale        | 30686, 30751, 30752, 30790, 31832  |
| Wilson            | 30831, 31233   |
| Windsor           | 30713  |
| Windy Sam         | 30573  |
| WIZE              | 31115  |
| Woxter            | 31005, 31151, 31224  |
| Xbox              | 30522, 31708   |
| Xenius            | 30790  |
| XLogic            | 30768, 31152, 31228  |
| XMS               | 30770, 30788   |
| Xoro              | 31183, 31250   |
| Yakumo            | 31004, 31056   |
| Yamada            | 30872, 31004, 31056, 31151, 31158  |
| Yamaha            | 30490, 30539, 30646, 30545, 31354  |
| Yamakawa          | 30665, 30872, 31104  |
| Yukai             | 30730, 31730   |
| Zenith            | 30503, 30591, 30741, 30869, 31906  |
| Zeus              | 30784  |

## DVD Recorder

|        |       |
|--------|-------|
| 1 4Kus | 31158 |
|--------|-------|

|                     |                     |
|---------------------|---------------------|
| Airis               | 31321               |
| Akira               | 31321               |
| Alba                | 31530               |
| Apex Digital        | 31056               |
| Aristona            | 30646               |
| Aspire Digital      | 31168               |
| Belson              | 31086               |
| Cat                 | 31421               |
| cello               | 31730               |
| Centrum             | 31227               |
| Classic             | 31730               |
| Coby                | 31086               |
| Commax              | 31321               |
| Conia               | 31321               |
| CyberHome           | 31129, 31502        |
| Cytron              | 31347               |
| Denon               | 30490               |
| Denver              | 31056               |
| Digitrex            | 31056               |
| DSE                 | 31730               |
| Durabrand           | 31502               |
| E:max               | 31321               |
| Ellion              | 31421               |
| Eltax               | 31321               |
| Emerson             | 30675               |
| Ferguson            | 31730               |
| Firstline           | 31530               |
| Funai               | 30675               |
| Gateway             | 31158               |
| Go Video            | 30741, 31158, 31730 |
| Goodmans            | 31530, 31730        |
| GPX                 | 30741               |
| Grundig             | 31730               |
| H & B               | 31421               |
| Humax               | 30646               |
| iLo                 | 31348               |
| JVC                 | 31164, 31597        |
| Kansas Technologies | 31530               |
| Kreisen             | 31421               |
| KXD                 | 31321               |
| LG                  | 30741               |
| Lifetec             | 31347               |
| LiteOn              | 31158               |
| Loewe               | 30741               |
| Lumatron            | 31321               |
| Luxor               | 31730               |
| Magnavox            | 30646, 30675        |
| Matsui              | 31730               |
| Maxent              | 31347               |
| MBO                 | 31730               |
| Medion              | 31347               |
| MiCO                | 30751               |

|                 |                                   |
|-----------------|-----------------------------------|
| Mitsubishi      | 31403                             |
| Mustek          | 31730                             |
| NEC             | 31404                             |
| Oopla           | 31158                             |
| Palsonic        | 31056, 31321                      |
| Panasonic       | 30490, 31579                      |
| Philips         | 30646, 31158                      |
| Pioneer         | 30631                             |
| Polaroid        | 31086                             |
| ProVision       | 31321                             |
| Pye             | 30646                             |
| RCA             | 30522                             |
| Relisys         | 31347                             |
| Roadstar        | 31227                             |
| Sampo           | 31347                             |
| Samsung         | 30490, 31635                      |
| ScanMagic       | 31730                             |
| Schneider       | 30646                             |
| SEG             | 31530                             |
| Sensory Science | 31158                             |
| Sharp           | 30630, 30675                      |
| Sony            | 31033, 31070, 31431, 31433, 31536 |
| Star Clusters   | 31227                             |
| Sylvania        | 30675                             |
| Tangent         | 31321                             |
| Targa           | 31227                             |
| Teac            | 31227                             |
| Techwood        | 31530                             |
| Tevion          | 31227, 31347, 31730               |
| Thomson         | 30551                             |
| Toshiba         | 31510                             |
| Universum       | 31227, 31530                      |
| Vestel          | 31530                             |
| Victor          | 31597                             |
| Waltham         | 31530                             |
| Yakumo          | 31056                             |
| Yamada          | 31056, 31158                      |
| Yamaha          | 30646                             |
| Yukai           | 31730                             |
| Zenith          | 30741                             |



| DVD preset codes / Codes pré-réglés DVD |                          |            |          |
|---|--------------------------|------------|----------|
| DENON                                   | 32134 (default / défaut) |            | 30490    |
| Model No. /<br>Modèle numéro            | DVD-555                  | DVD-2910   | DVD-800  |
|   | DVD-755                  | DVD-2930CI | DVD-1600 |
|   | DVD-900                  | DVD-3800   | DVD-2000 |
|   | DVD-910                  | DVD-3910   | DVD-2500 |
|   | DVD-955                  | DVD-3930CI | DVD-3000 |
|   | DVD-1000                 | DVD-5900   | DVD-3300 |
|   | DVD-1200                 | DVD-5910   |          |
|   | DVD-1500                 | DVD-9000   |          |
|   | DVD-1710                 | DVM-715    |          |
|   | DVD-1910                 | DVM-1800   |          |
|   | DVD-1930CI               | DVM-1805   |          |
|   | DVD-2200                 | DVM-1815   |          |
|   | DVD-2800                 | DVM-2815   |          |
|   | DVD-2800II               | DVM-4800   |          |
|   | DVD-2900                 |            |          |

[ ]\*: Preset codes set upon shipment from the factory.  
: Les codes pré-réglés diffèrent en fonction des livraisons de l'usine.

※1 : These preset codes can be recorded in the SAT/CBL mode.  
: Ces codes de présélection peuvent être enregistrés en mode SAT/CBL.

※2 : These preset codes can be recorded in the TV mode.  
: Ces codes de présélection peuvent être enregistrés en mode TV.

※3 : These preset codes can be recorded in the VCR mode.  
: Ces codes de présélection peuvent être enregistrés en mode VCR.

※4 : These preset codes can be recorded in the DVD mode.  
: Ces codes de présélection peuvent être enregistrés en mode DVD.

**DENON**

[www.denon.com](http://www.denon.com)

Denon Brand Company, D&M Holdings Inc.  
Printed in Japan 00D 511 4654 101A